

Firestone

AIRIDE

riderite.com

INSTALLATION INSTRUCTIONS

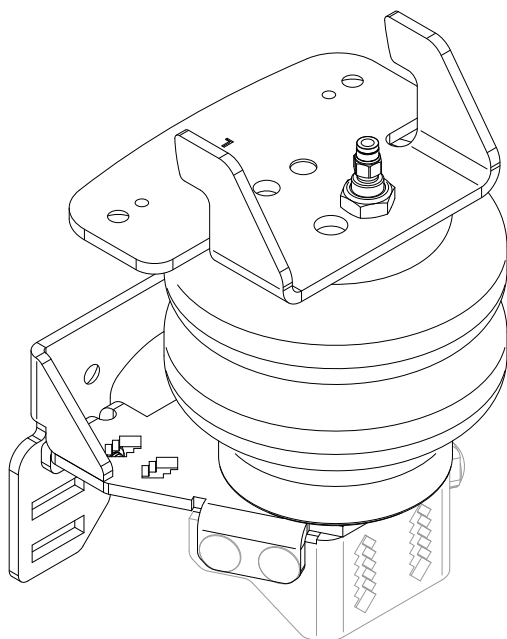

SECTION 1 - AIR SPRING

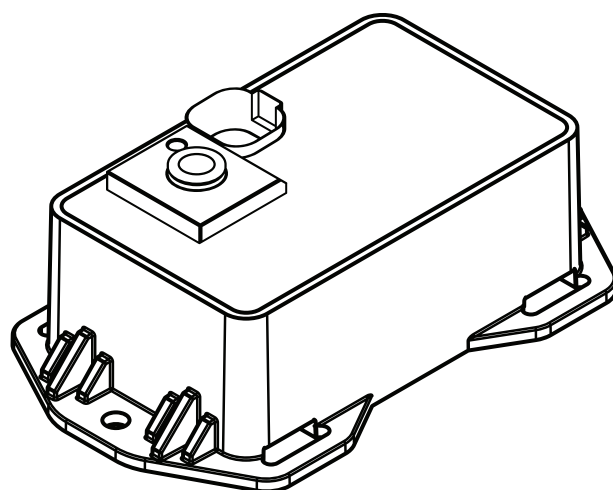

SECTION 2 - AIR ACCESSORY

Firestone

AIRIDE

firestoneairide.com

INSTALLATION INSTRUCTIONS

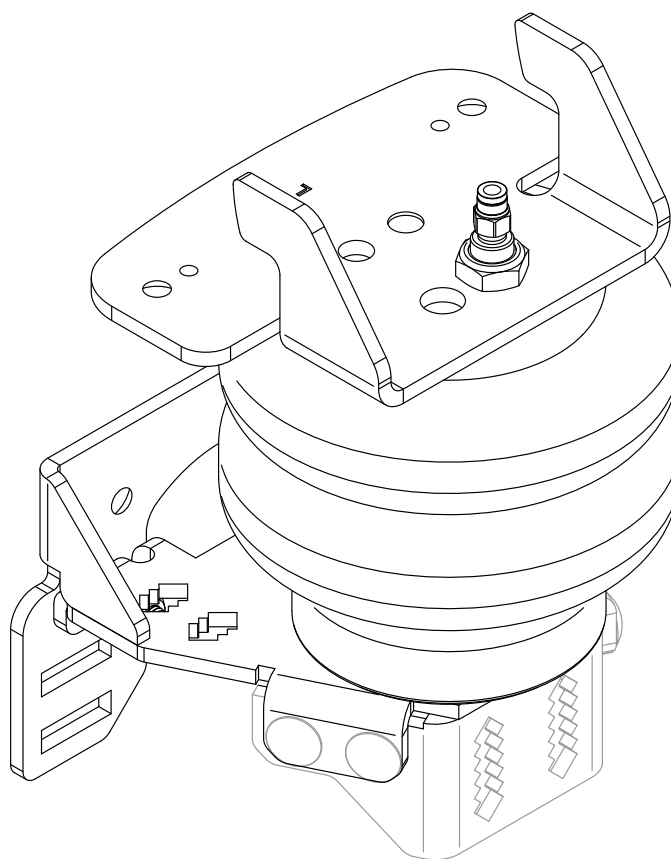

! IMPORTANT

PLEASE DON'T HURT YOURSELF, YOUR KIT OR YOUR VEHICLE. TAKE A MINUTE TO READ THIS IMPORTANT INFORMATION.

DO NOT INSTALL IF THE TRUCK HAS BEEN LIFTED AND THE STOCK JOUNCE BUMPER SPACERS ARE NOT ON THE VEHICLE. *This kit is to be used on a **pickup truck only**, and **DOES NOT INCREASE YOUR VEHICLE'S MAXIMUM LOAD.***

SAFE INSTALLATION

Please take all safety precautions during installation. A hydraulic jack can fail, and if that happens, you can be seriously hurt, or worse, if you are relying on it to hold up the vehicle. If you use a hydraulic jack, secure jack stands in the appropriate locations and chock any tires still touching the ground.

Wear safety glasses or goggles. Your eyes may be lower than some parts and pieces, and you don't want to lose an eye.

Remove the possibility of any electrical issues by disconnecting the negative battery cable.

KIT CLEARANCE

There must be a minimum of 1/2" clearance around all installed components when the air springs are inflated and under a load. The air springs must flex and expand during operation, so the clearance keeps the kit from rubbing against parts of the vehicle.

VEHICLE GVWR

NEVER exceed the maximum load recommended by the vehicle manufacturer (GVWR). The GVWR can be found in your vehicle's owner's manual or on the data plate on the driver's side door. Consult your local dealership for additional GVWR specifications.

INFLATING THE AIR SPRINGS

When inflating air springs, add air pressure in small quantities, checking air pressure frequently. The air springs have much less air volume than a tire, so they inflate much more quickly.

PRESSURE TO LOAD

The air springs will support approximately 50 lbs. of load for each PSI of inflation pressure (per pair). For example, 50 PSI of inflation pressure will support a load of 2500 lbs. per pair of air springs.

APPROPRIATE AIR PRESSURE

For best ride, use only enough air pressure in the air springs to level the vehicle when viewed from the side (front to rear). This will vary, depending on the load, location of the load, condition of the existing suspension, and personal preference.

OPTIONAL T-FITTING

This kit includes inflation valves and air line tube for each air spring, allowing you to compensate for unbalanced loads. If you prefer a single inflation valve system to provide equal pressure to both air springs, your dealer can supply the optional "T" fitting (Part # 3025 or WRI-760-3461 retail pack).



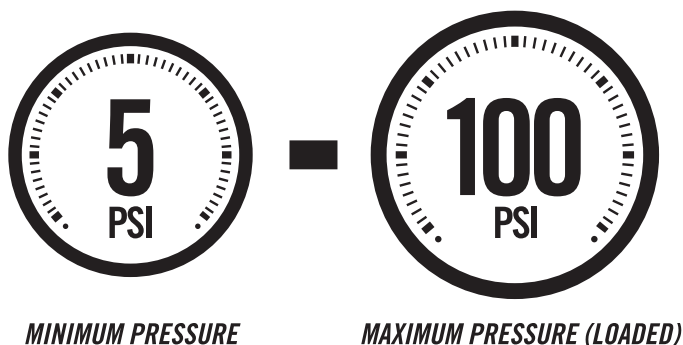



ONCE INSTALLED SUCCESSFULLY, FOLLOW THESE PRESSURE REQUIREMENTS FOR THE AIR SPRINGS:

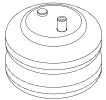
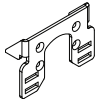
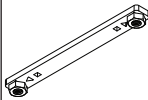
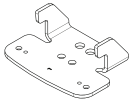
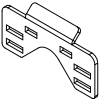

PARTS

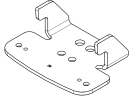
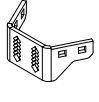

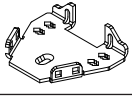
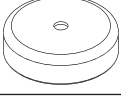
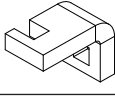
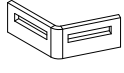



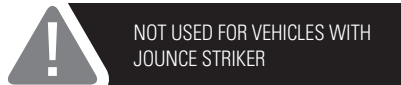





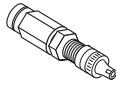

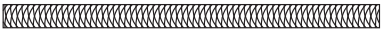

Compare the parts below to your kit. Assure you have all pieces, and organize them for an easier installation.

MAIN KIT CONTENTS

PT # 6397	 x 2 AIR SPRING	PT # 5939	 x 2 LOWER FRAME BRACKET	PT # 5940	 x 2 THREAD PLATE
PT # 5872	 x 1 UPPER LEFT BRACKET	PT # 5942	 x 2 LEAF SPRING BRACKET	PT # 1004	 x 1 HEAT SHIELD
PT # 5873	 x 1 UPPER RIGHT BRACKET	PT # 5957	 x 2 SUPPORT BRACKET 	PT # 9415	 x 1 AIR LINE TUBE (22 FEET)
PT # 5958	 x 2 LOWER BRACKET	PT # 5336	 x 2 AIR SPRING SPACER	PT # 5946	 x 8 UNIVERSAL AXLE BRACKET
PT # 5959	 x 2 SHORT SUPPORT BRACKET 	PT # 0045	 x 2 PROTECTOR		

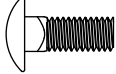

A21-760-2625 HARDWARE PACK

PT # 3022	 x 26 3/8" - 16 FLANGE LOCK NUT	PT # 3514	 x 6 3/8" - 16 x 1" FLAT HEAD CAP SCREW	PT # 3032	 x 2 INFLATION VALVE AND VALVE CAP ASSEMBLY
PT # 3033	 x 4 5/16" FLAT WASHER	PT # 3430	 x 2 3/8" - 16 x 2" FLAT HEAD CAP SCREW	PT # 3055	 x 2 AIR FITTING
PT # 0899	 x 2 THERMAL SLEEVE	PT # 3481	 x 2 3/8" - 16 x 3" CARRIAGE BOLT	PT # 3502	 x 8 3/8" - 16 x 6" CARRIAGE BOLT
PT # 3020	 x 4 3/8" - 16 X 8" CARRIAGE BOLT	PT # 3332	 x 2 5/8" - 18 NYLON JAM NUT	PT # 9036	 x 10 RED NYLON TIE
PT # 9488	 x 2 LARGE NYLON TIE	PT # 9483	 x 1 NO-DRILL INFLATION VALVE BRACKET	PT # 3072	 x 8 3/8" - 16 x 1" CARRIAGE BOLT
PT # 3515	 x 4 3/8" - 16 x 2.5" FLAT HEAD CAP SCREW				

! NOTICE

This kit includes components that allow multiple build configurations.

Not every part will be used for each configuration.

CONTENTS AND OVERVIEW

JOUNCE STRIKER CONFIGURATION SHOWN - CHECK YOUR VEHICLE FIRST!

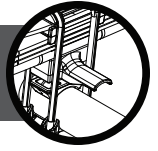

PAGE **6** REMOVE EXISTING JOUNCE BUMPER & INSTALL THREAD PLATE

PAGE **7** INSTALL UPPER BRACKET

PAGE **9** CREATE LOWER BRACKET ASSEMBLY

PAGE **11** DRY FIT AIR SPRING

PAGE **14** DRY FIT AIR SPRING

PAGE **12** MAKE ALIGNMENT MARKS

PAGE **15** MAKE ALIGNMENT MARKS

PAGE **13** DRY FIT LOWER BRACKET ASSEMBLY

PAGE **16** DRY FIT LOWER BRACKET ASSEMBLY

PAGE **17** MEASURE BETWEEN BRACKETS & INSTALL AIR SPRING

PAGE **18** INSTALL AIR SPRING INTO UPPER BRACKET

PAGE **19** INSTALL LOWER BRACKET ASSEMBLY

PAGE **20** INSTALL AXLE STRAP BRACKET

PAGE **21** INSTALL HEAT SHIELD ON RIGHT SIDE

PAGE **22** INSTALL INFLATION VALVES & CUT THE AIR LINE TUBE INTO TWO EQUAL LENGTHS

PAGE **23** ROUTE AND SECURE AIR LINE TUBES & INSTALLING AIR LINE TUBE

PAGE **24** CHECKING THE AIR SYSTEM

PAGE **21** FIXING AN AIR LEAK

PAGE **21** FINISHING THE INSTALLATION



YOUR VEHICLE WILL REQUIRE ADDITIONAL PARTS FROM THIS KIT IF IT DOES NOT HAVE A JOUNCE STRIKER

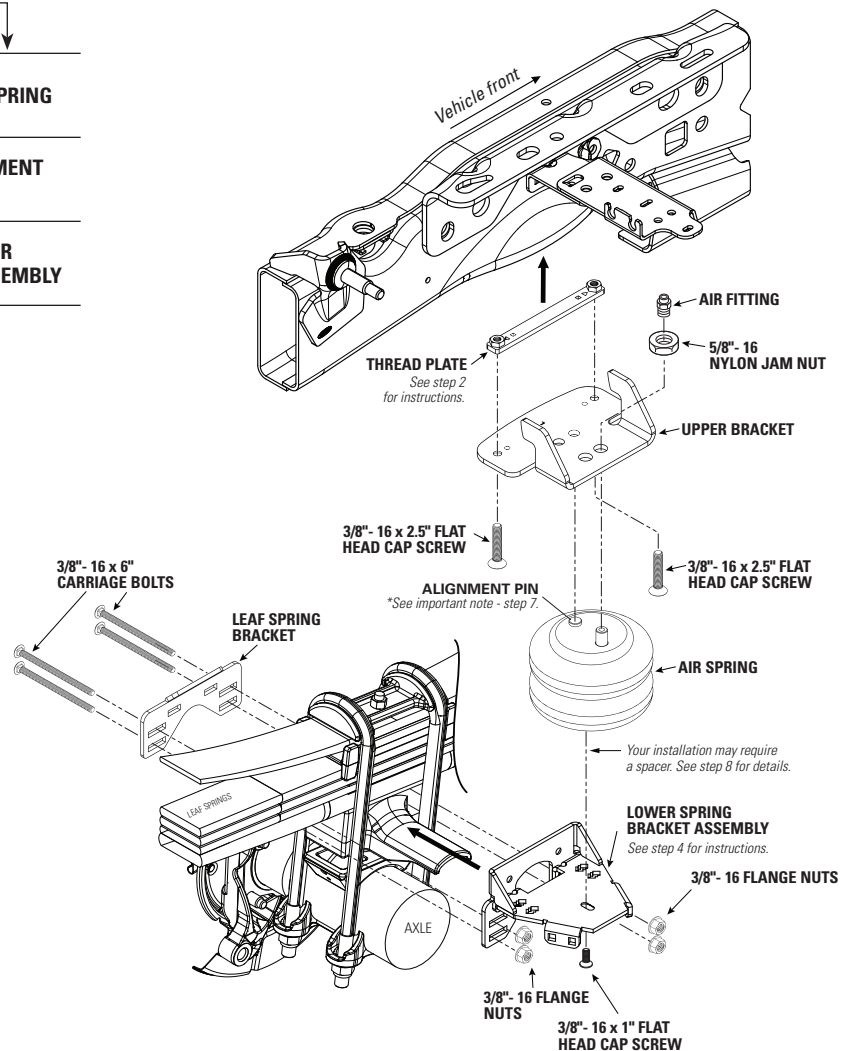

! IMPORTANT NOTE

If necessary for installation clearance, slightly bend the brackets on the left (driver) side which supports the brake line and axle vent tube. After removing the plastic ABS mount from its hole in the axle bracket, use an adjustable wrench or similar tool to bend the bracket approximately 1/8" (3mm). Replace the ABS mount when proper clearance is obtained.

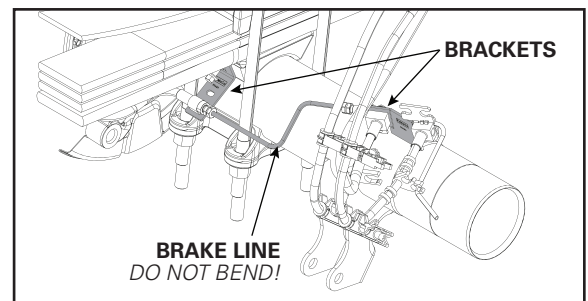

1

REMOVE EXISTING JOUNCE BUMPER



START ON THE LEFT SIDE OF THE VEHICLE WHILE FACING FORWARD.

Remove the existing jounce bumper and fastener clips from the vehicle frame.

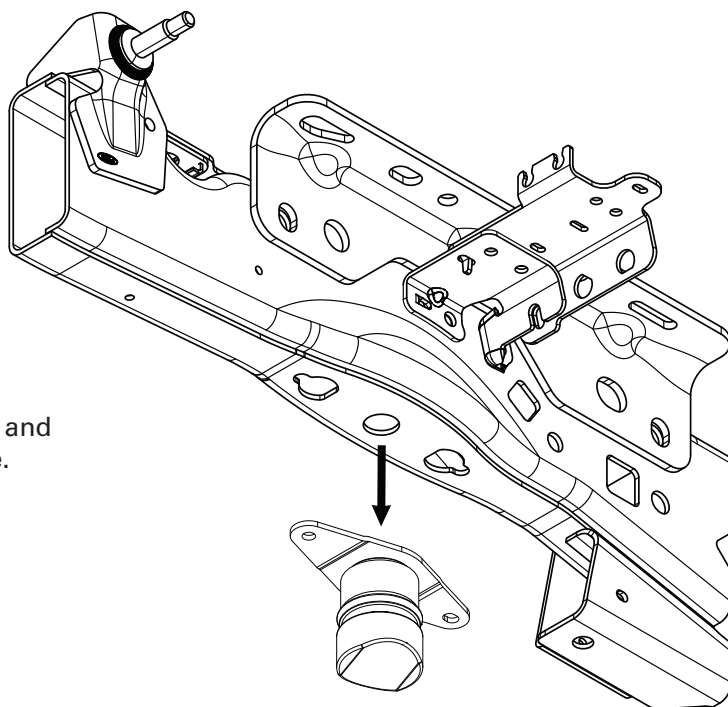

2

INSTALL THREAD PLATE

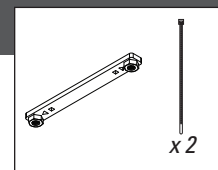

Attach nylon ties to the thread plate, as shown. These act as installation guides for the thread plate and upper bracket. They will be removed in a later step.

Insert the thread plate into the vehicle frame, as shown. Use nylon ties as handles to position thread plate.

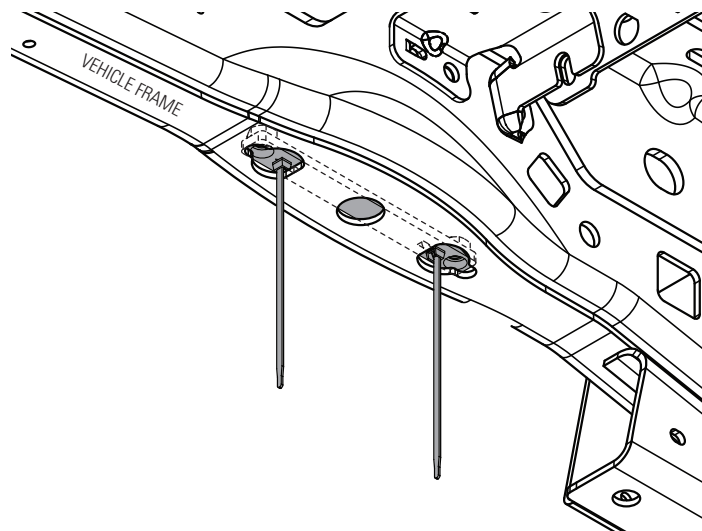
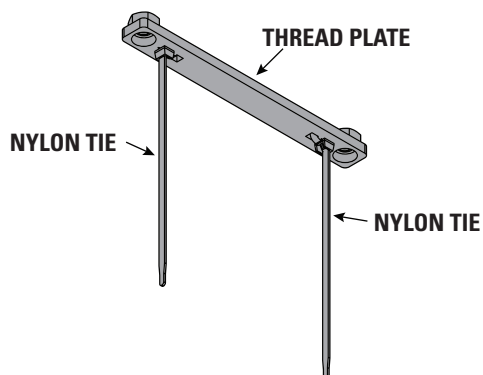

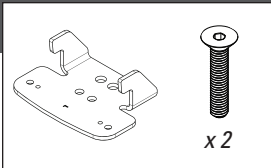

- 1** Guide the two nylon ties into the inner holes in the upper bracket.
- 2** While holding the thread plate in place with the nylon ties, **hand-thread** the fasteners in place.
- 3** Once the fasteners have begun engaging the threads, use snips or a knife to trim the nylon ties flush with the frame.
- 4** Fully-tighten the fasteners.

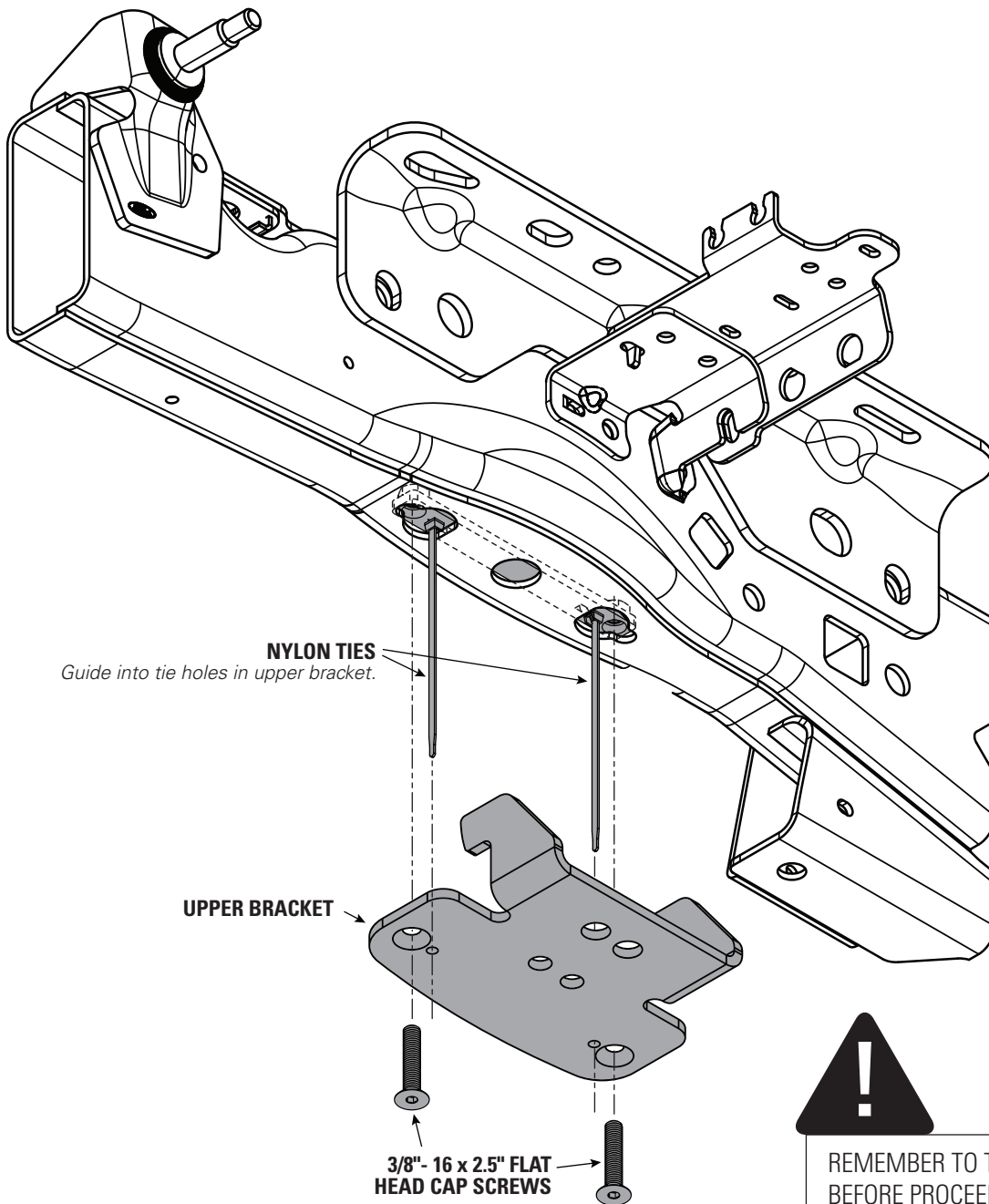

! WARNING

The lower bracket must be supported by the factory jounce striker (if present) or by the installation of the appropriate support bracket.

Failure to support the lower bracket will cause mounting system failure and void all warranty.

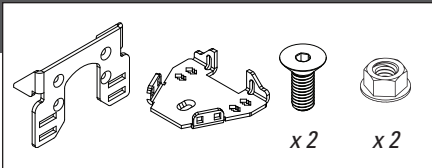

Fasten the lower spring bracket to the lower frame bracket, as shown. **Assure that the lower spring bracket flanges are pointing downward.**

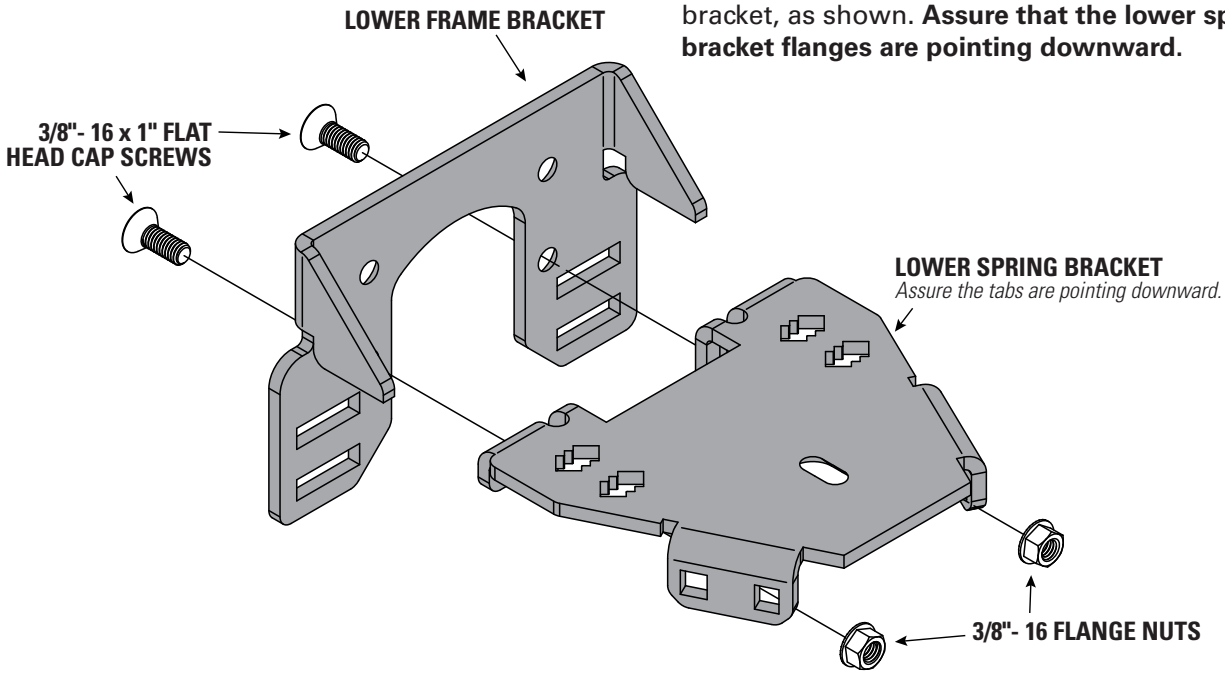

! NOTICE

**If your truck has a jounce
striker plate as shown
below, continue to the
next step.**

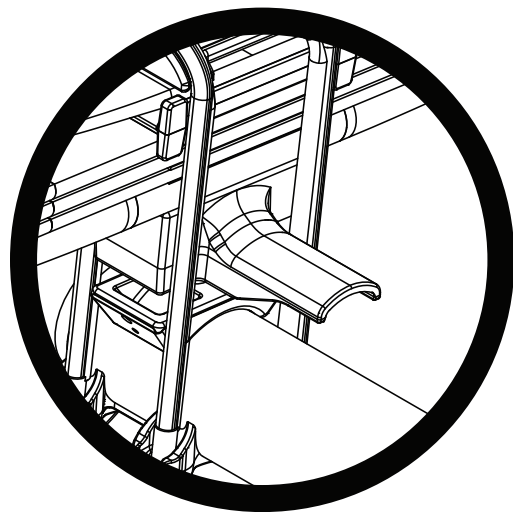

**If it does not, skip to step 5
on page 14.**

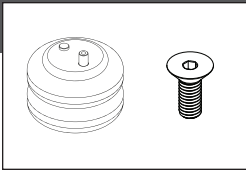

Jounce striker plate version only

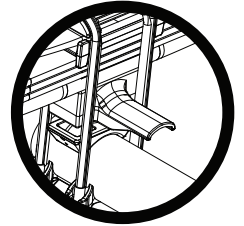

Fasten the air spring to the lower spring bracket.
DO NOT FULLY TIGHTEN AT THIS STAGE.

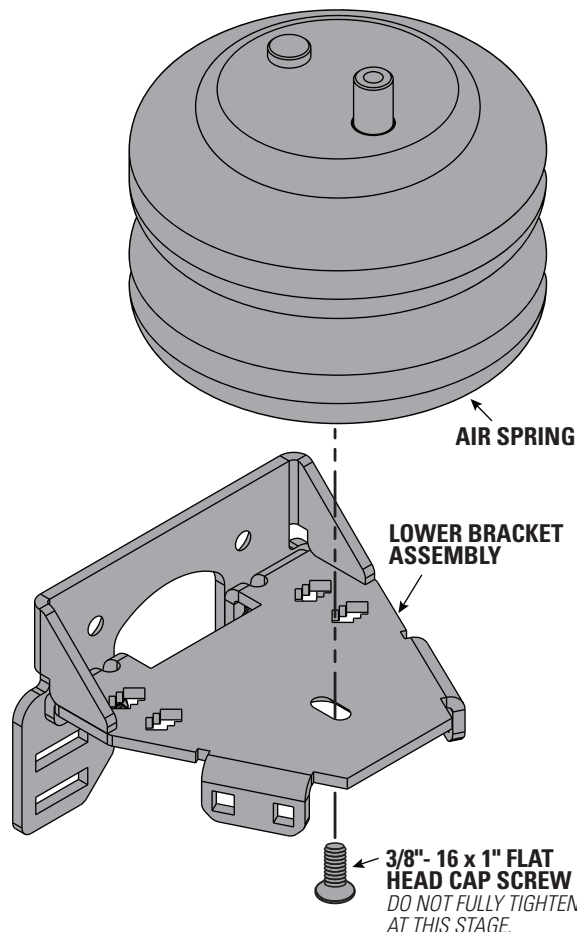

Jounce striker plate version only

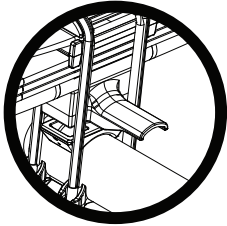

- 1 Insert the alignment pin and combo stud into the front alignment holes, as shown.
- 2 Position the lower bracket assembly tight to the u-bolts and assure the combo stud and alignment pin are fully seated.
- 3 Make alignment marks, as shown.

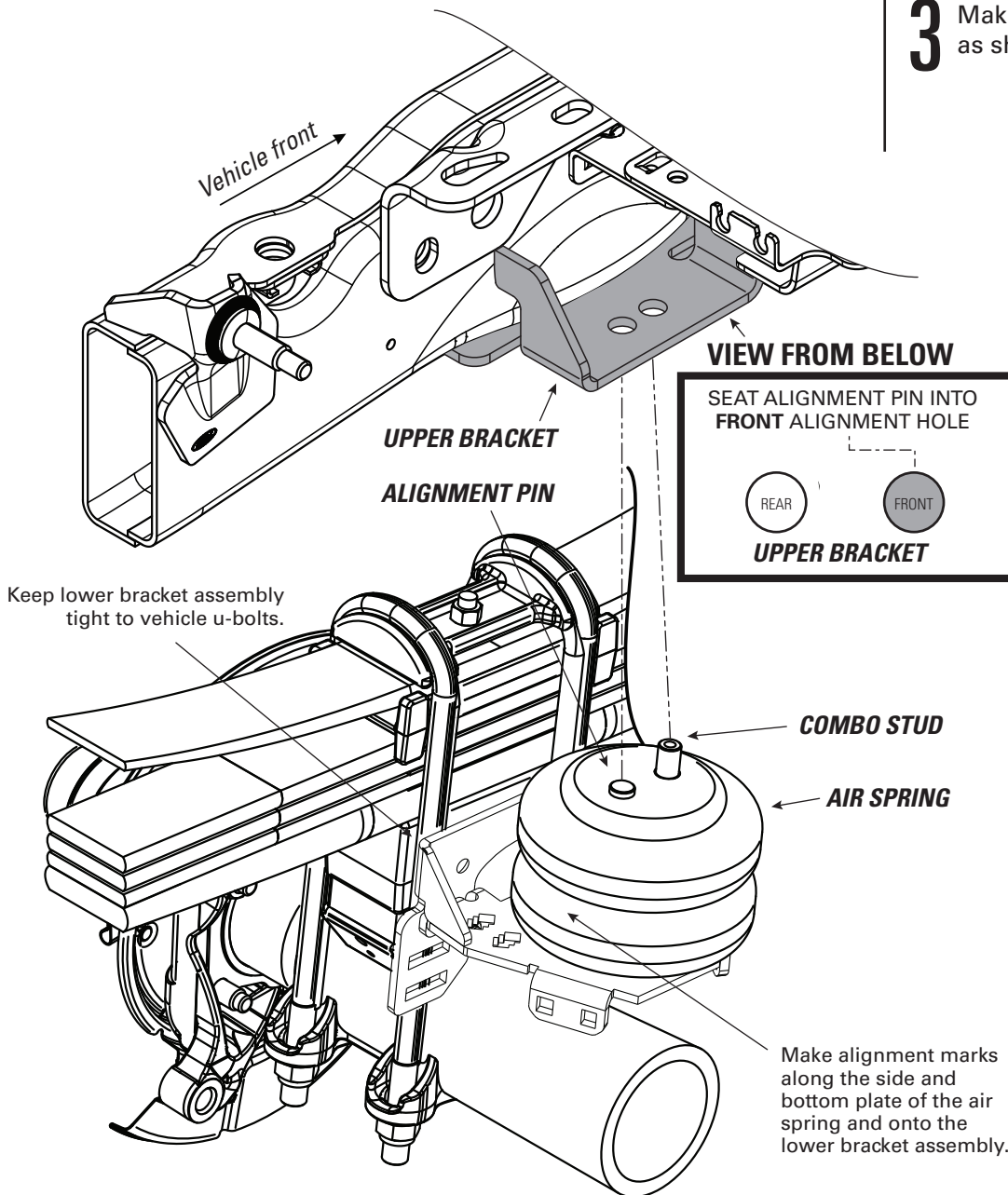

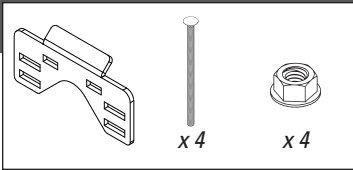

Jounce striker plate version only

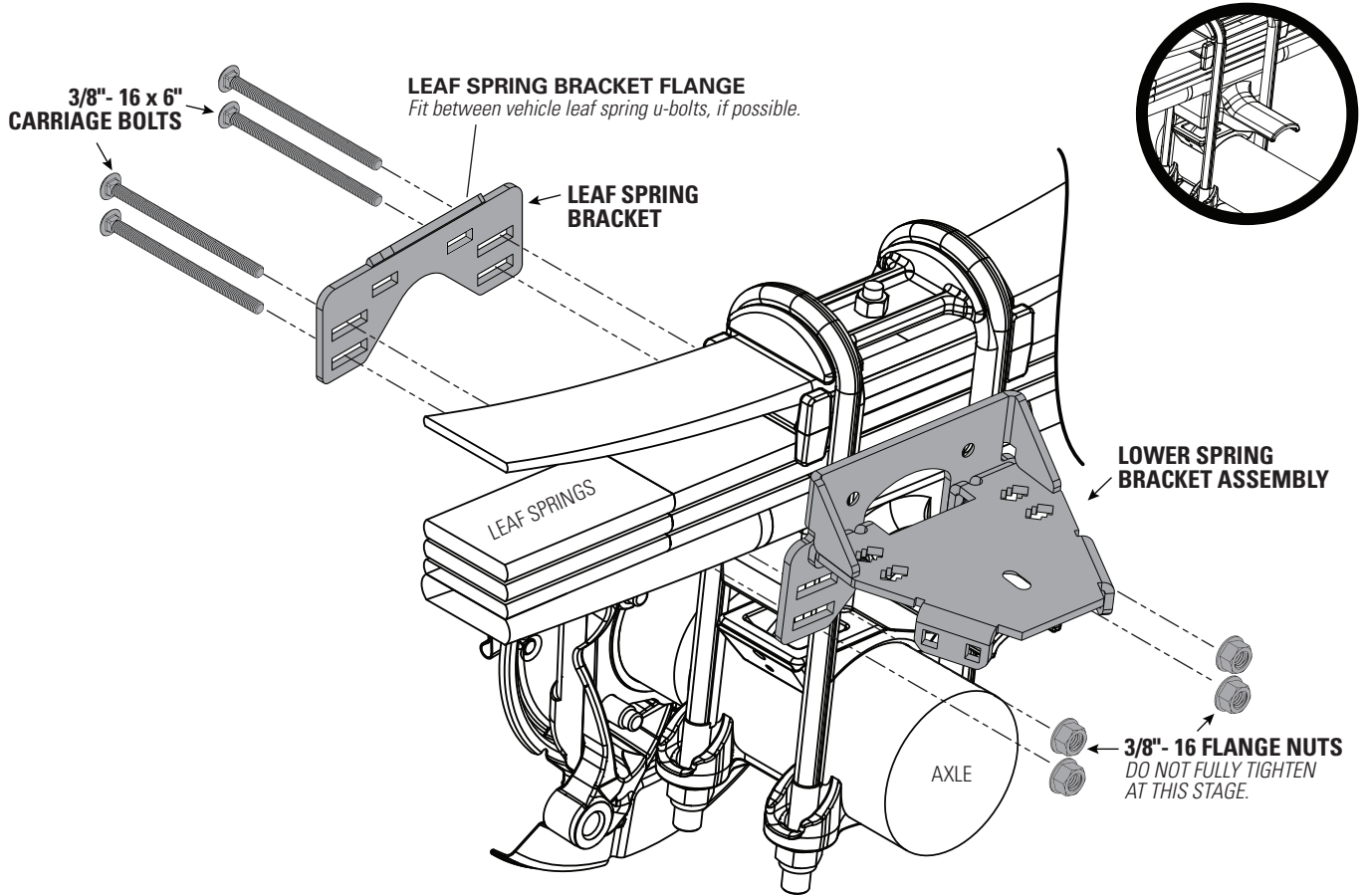

1 Remove air spring and fastener from lower bracket assembly.

2 Install the lower bracket assembly so that it is tight against the vehicle jounce tongue and leaf spring stack.

3 Do not fully tighten at this stage. You will remove the assembly after the next step.

Continue to bracket measuring instructions step 8 on page 17.

5b

DRY FIT AIR SPRING

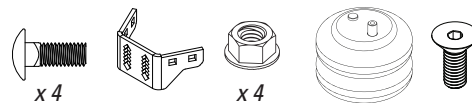

Support bracket version only

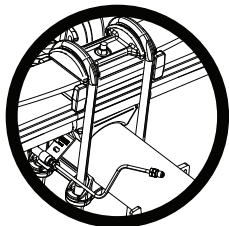

IF CARRIAGE BOLTS IN STEP 7B INTERFERE WITH LEAF SPRING, 5959 SHORT SUPPORT BRACKET MAY BE ATTACHED TO EITHER SIDE OF 5958 LOWER BRACKET INSTEAD OF 5957

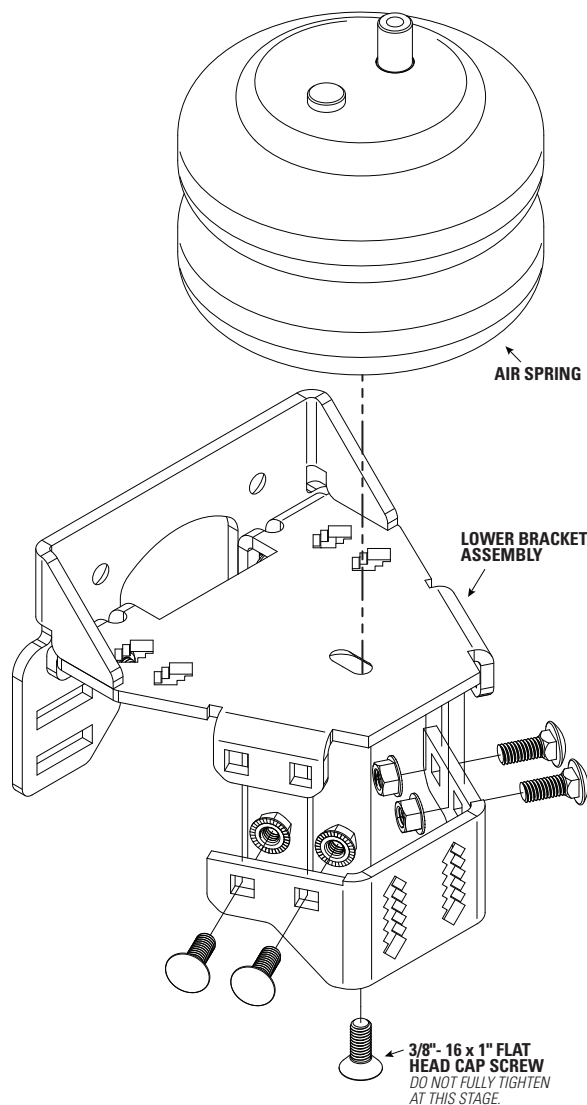
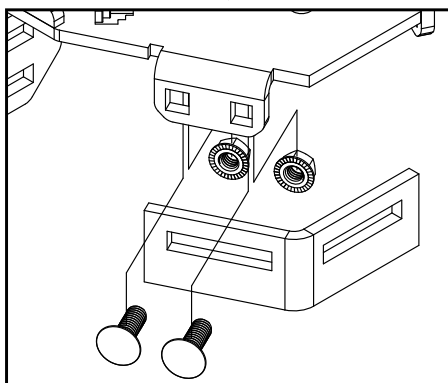

Fasten the air spring to the lower spring bracket.
DO NOT FULLY TIGHTEN AT THIS STAGE.

Support bracket version only

1 Insert the alignment pin and combo stud into the front alignment holes, as shown.

2 Position the lower bracket assembly tight to the u-bolts and assure the combo stud and alignment pin are fully seated.

3 Make alignment marks, as shown.

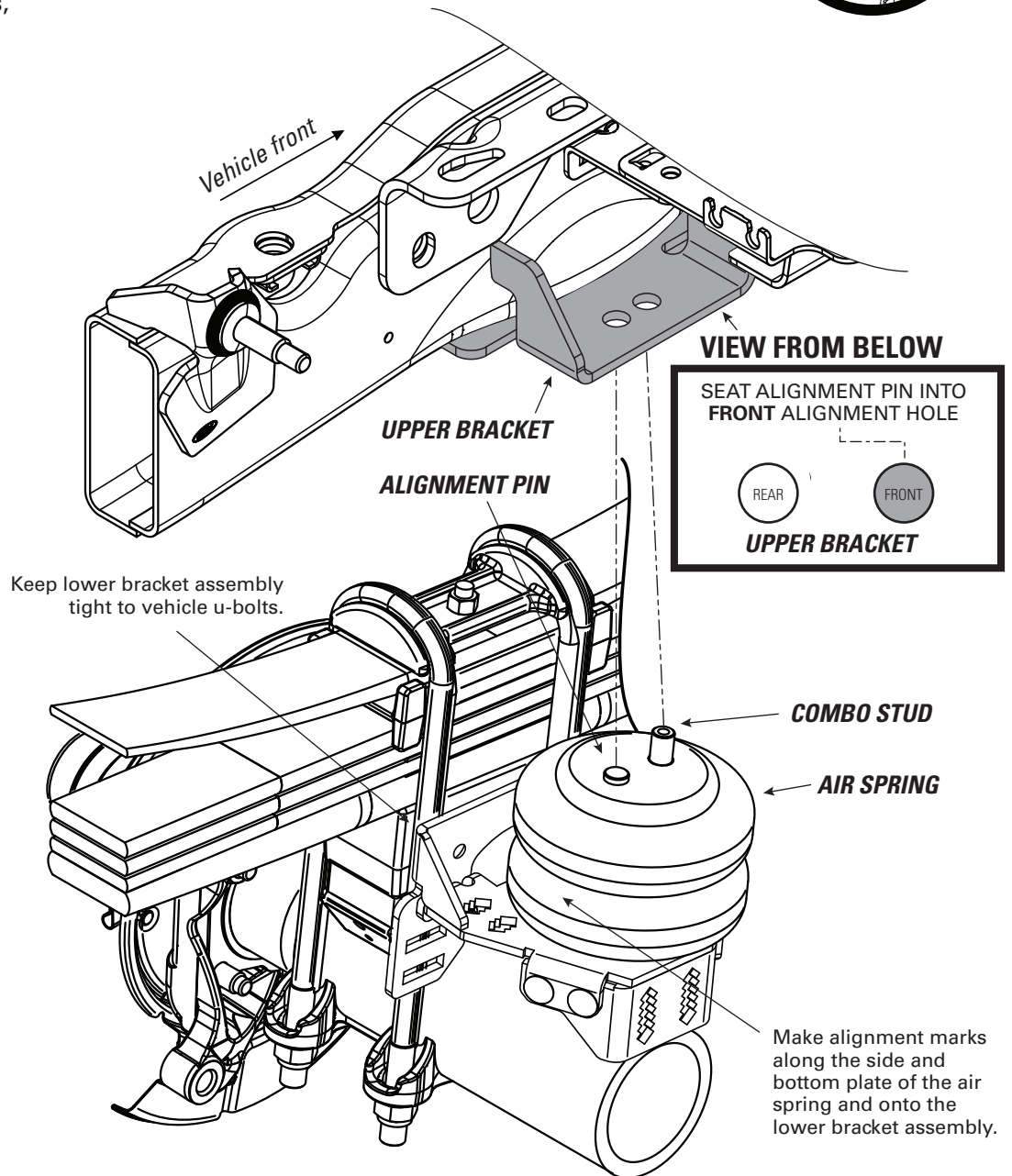
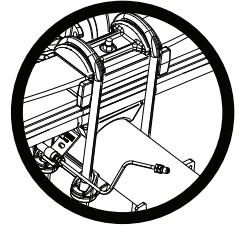

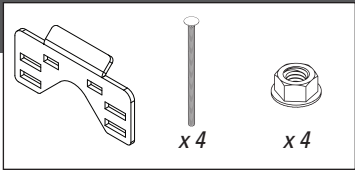

Support bracket version only

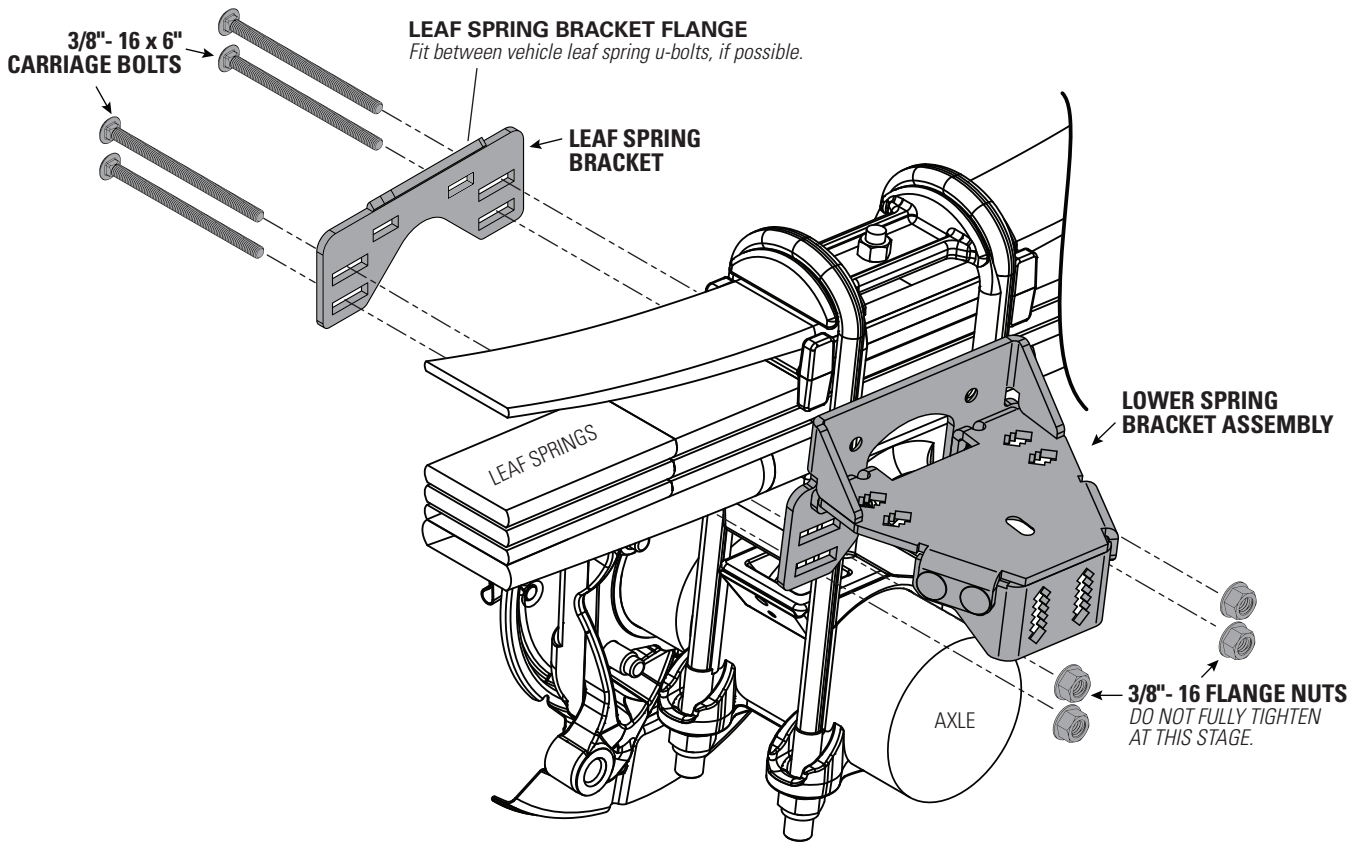
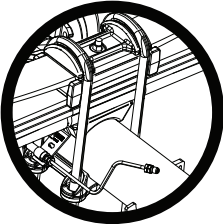

1 Remove air spring and fastener from lower bracket assembly.

2 Install the lower bracket assembly so that it is tight against the vehicle jounce tongue and leaf spring stack.

3 Do not fully tighten at this stage. You will remove the assembly after the next step.

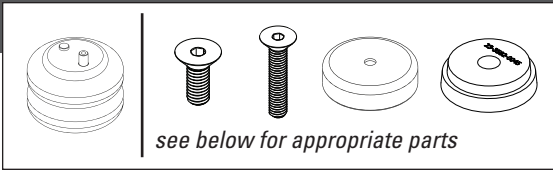

With vehicle unloaded on level ground and supporting its own weight, measure the distance between the bottom of the upper bracket and the top of the lower bracket. Use your measurement to follow the appropriate steps below.

STANDARD INSTALLATION

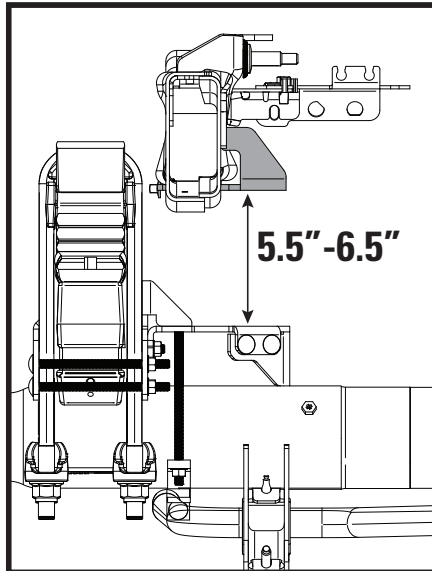

5.5\"/>

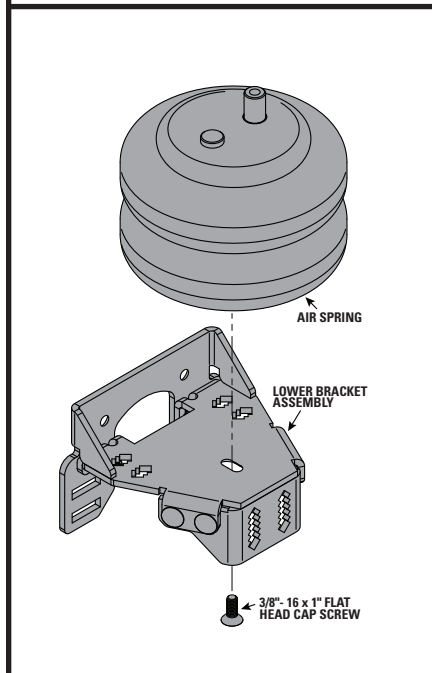

INSTALLATION WITH SPACER

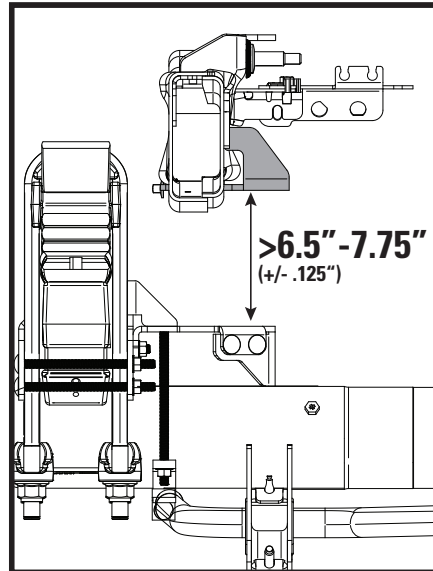

> 6.5\"/>

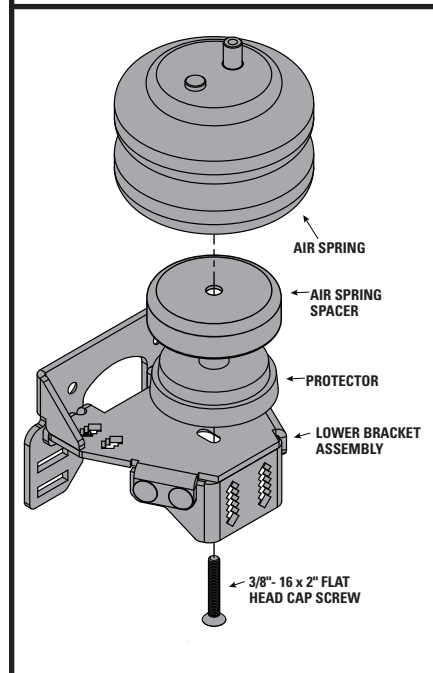

LARGER SPACER REQUIRED

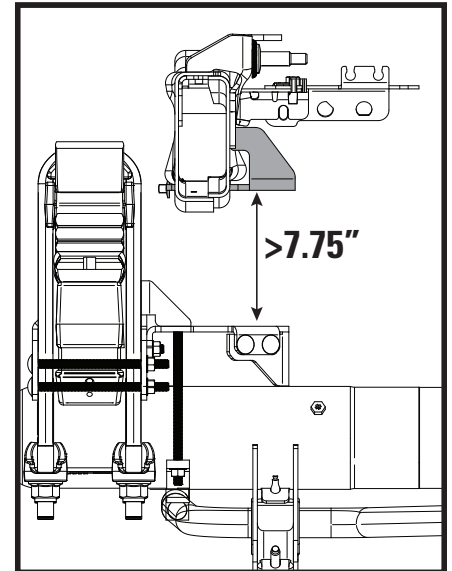

> 7.75\"/>

See Firestone catalog to order correct spacer to achieve the proper 5.5\"/>

! THE SUPPORT BRACKET VERSION IS SHOWN. MEASUREMENT PROCEDURE IS SAME FOR EITHER CONFIGURATION.

! YOUR ALIGNMENT MARKS MUST LINE UP BEFORE FULLY TIGHTENING THE CAP SCREW.

9

INSTALL AIR SPRING TO UPPER BRACKET



INSTALLING THE RIGHT SIDE? REMEMBER TO INSTALL THE HEAT SHIELD IN STEP 11 FIRST!

1 Install the air spring combo stud into the **front** alignment hole in the upper bracket. Fully-seat the air spring alignment pin into the **front** alignment hole.

2 Fully tighten the top of the air spring to the upper bracket.

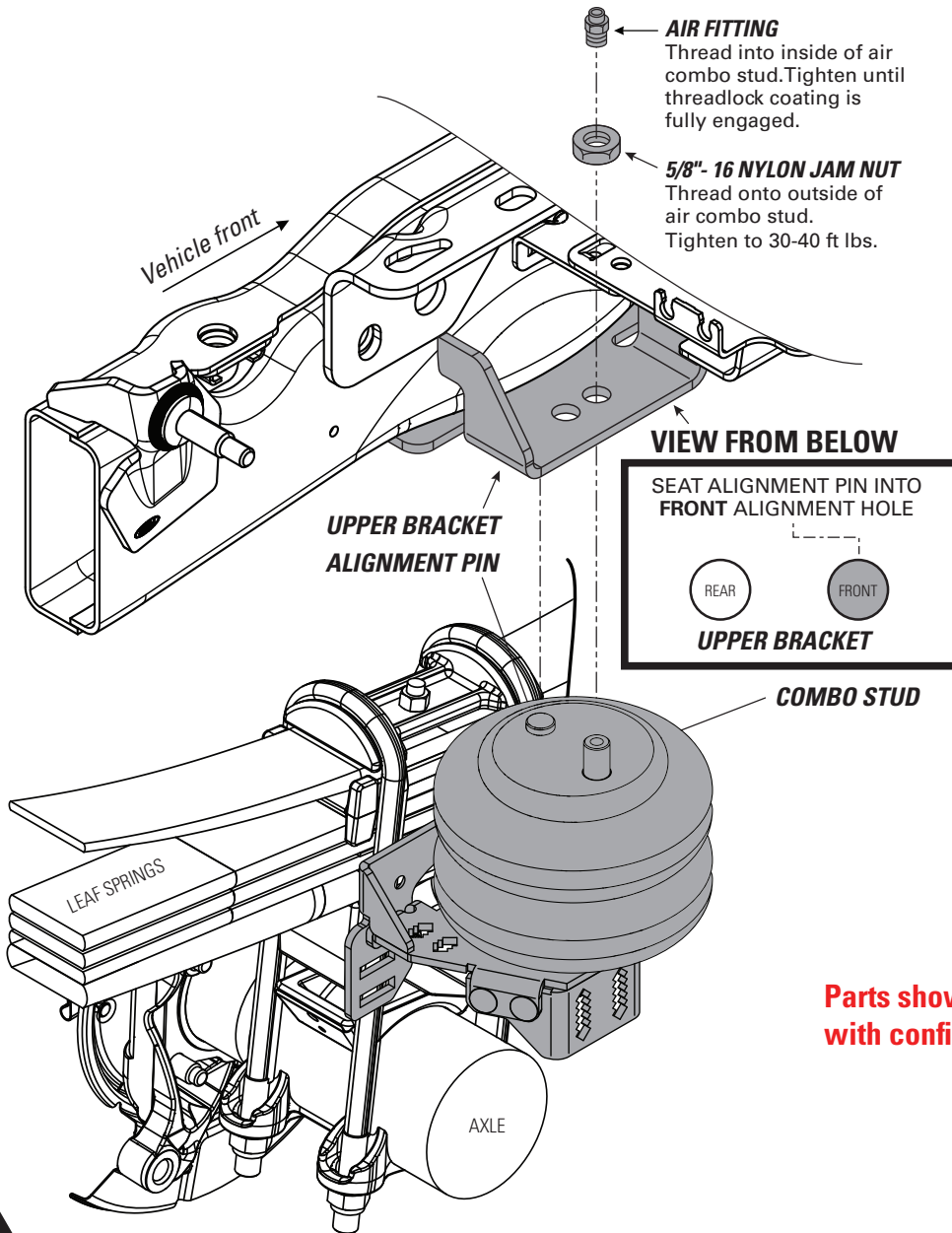

AIR FITTING
Thread into inside of air combo stud. Tighten until threadlock coating is fully engaged.

5/8"- 16 NYLON JAM NUT
Thread onto outside of air combo stud. Tighten to 30-40 ft lbs.

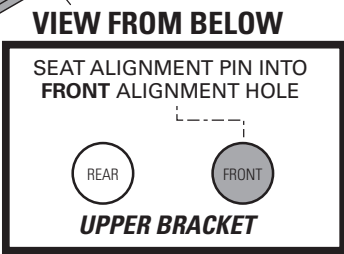

Parts shown will vary with configuration



ALIGNMENT PIN ON AIR SPRINGS MUST BE INSTALLED TO FULLY SEAT INTO THE FRONT ALIGNMENT HOLE IN THE UPPER BRACKET. FAILURE TO DO SO WILL CAUSE IT TO BE PUSHED INTO THE BEAD PLATE, CREATING AN AIR LEAK, AND RESULTING IN AN AIR SPRING FAILURE THAT IS **NOT WARRANTABLE**. **THE ALIGNMENT PIN CANNOT HOLD 2,500 LBS! IT IS USED FOR ALIGNMENT ONLY!**

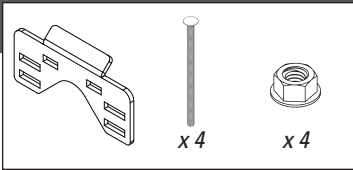

1 Place the lower bracket assembly on top of the jounce bumper tongue and against the inboard side of the vehicle leaf spring stack.

2 Place the leaf spring bracket on the outboard side of the leaf spring stack. If possible, fit the leaf spring bracket flange between the vehicle leaf spring u-bolts.

3 Install the fasteners as shown.

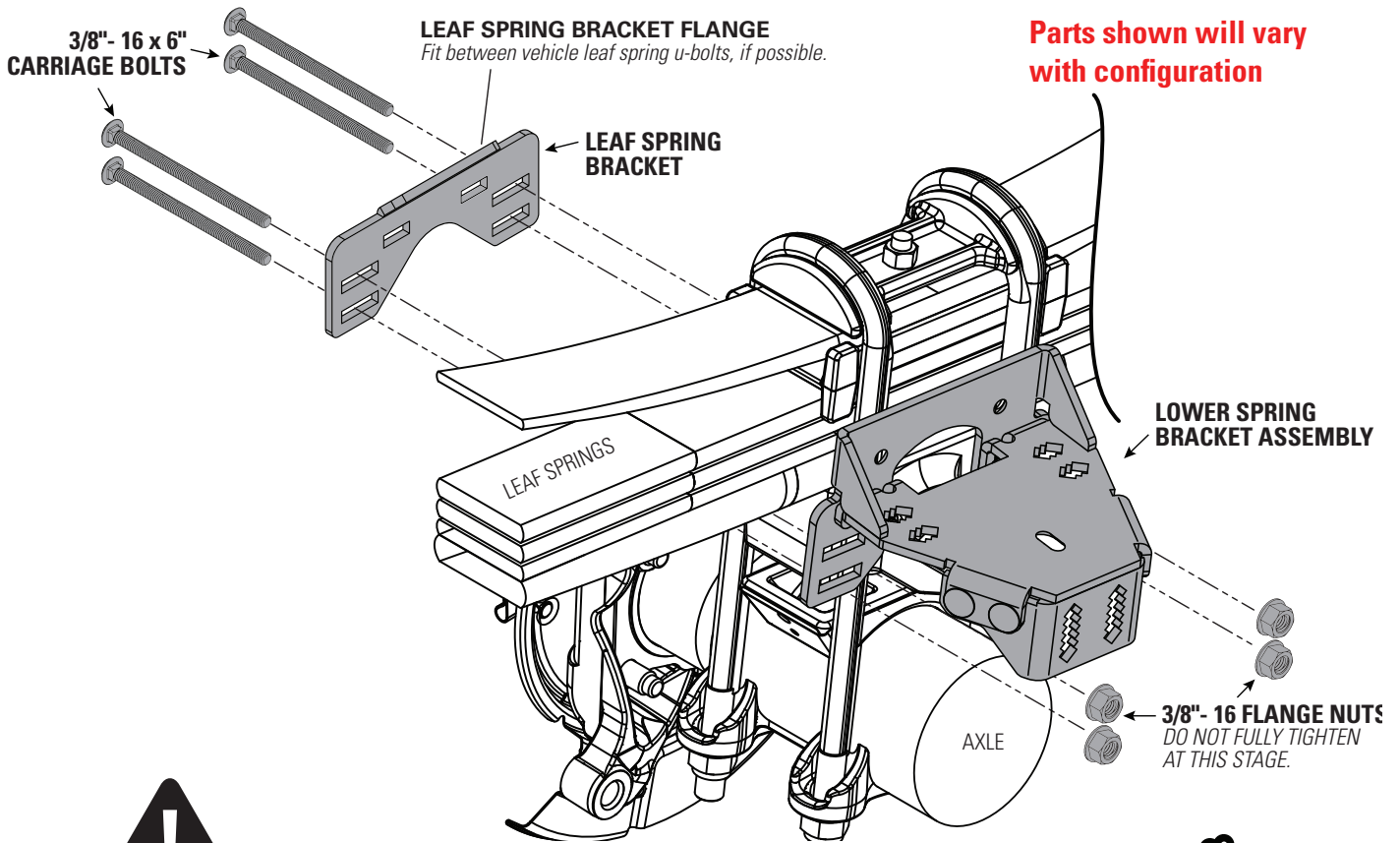

USE YOUR HAND TO CHECK FOR THE PROPER CLEARANCE AROUND THE AIR SPRING. IF YOUR HAND DOES NOT FIT BETWEEN THE AIR SPRING AND OTHER COMPONENTS, IT WILL RUB!



AWESOME! You're done with the left side. The right side is the same, with the addition of the heat shield. See step 8, then complete the steps for the right side installation.

11

INSTALL AXLE STRAP BRACKET

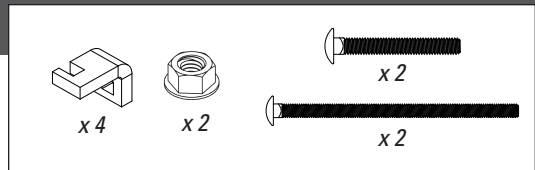

- 1 Link two pairs of universal axle brackets together to form an "M" as shown below.
- 2 Insert large carriage bolt into the hole of the lower bracket closest to the leaf spring and axle tube with the bolt as upright as possible.
- 3 Loosely attach one pair of universal axle brackets across the bottom with a small carriage bolt with a flange lock nut.
- 4 Connect both pairs of universal axle brackets across the bottom with a small carriage bolt and a flange lock nut.
- 5 Completely tighten all fasteners.

! THE SUPPORT BRACKET VERSION IS SHOWN. THE INSTALLATION IS THE SAME FOR EITHER CONFIGURATION.

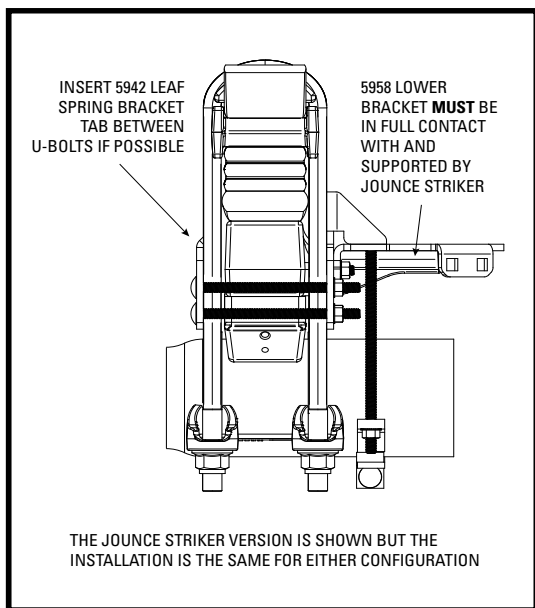
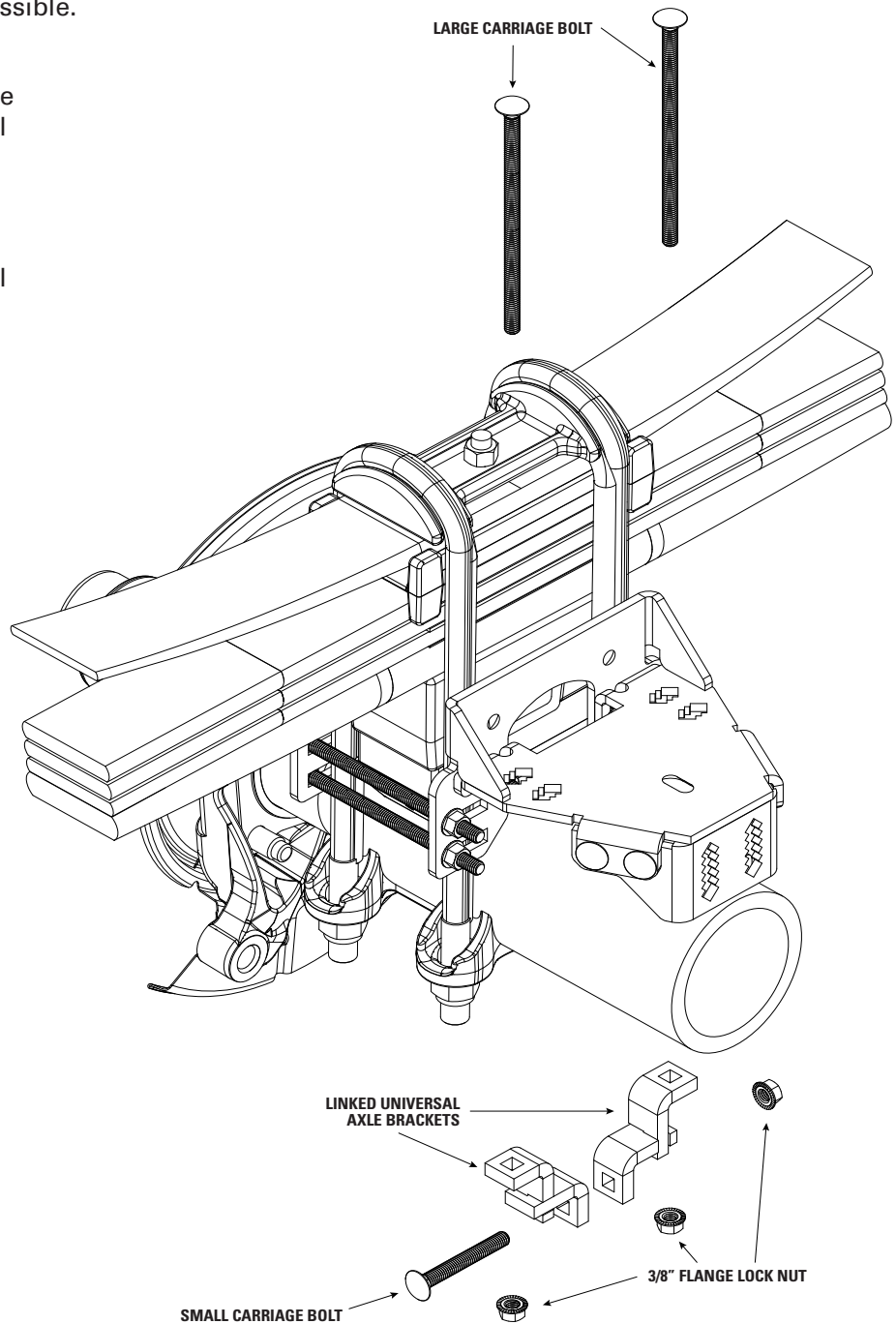

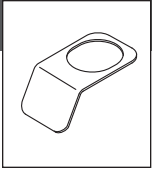

RIGHT SIDE INSTALLATION MUST INCLUDE HEAT SHIELD!

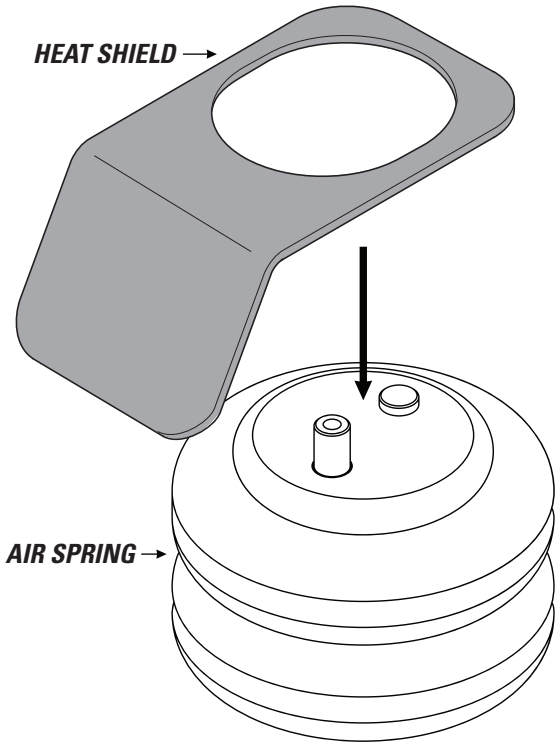

Parts shown will vary with configuration

AIR SPRING →

HEAT SHIELD →

Position heat shield to closest point of exhaust. DO NOT PLACE DIRECTLY ABOVE AXLE.

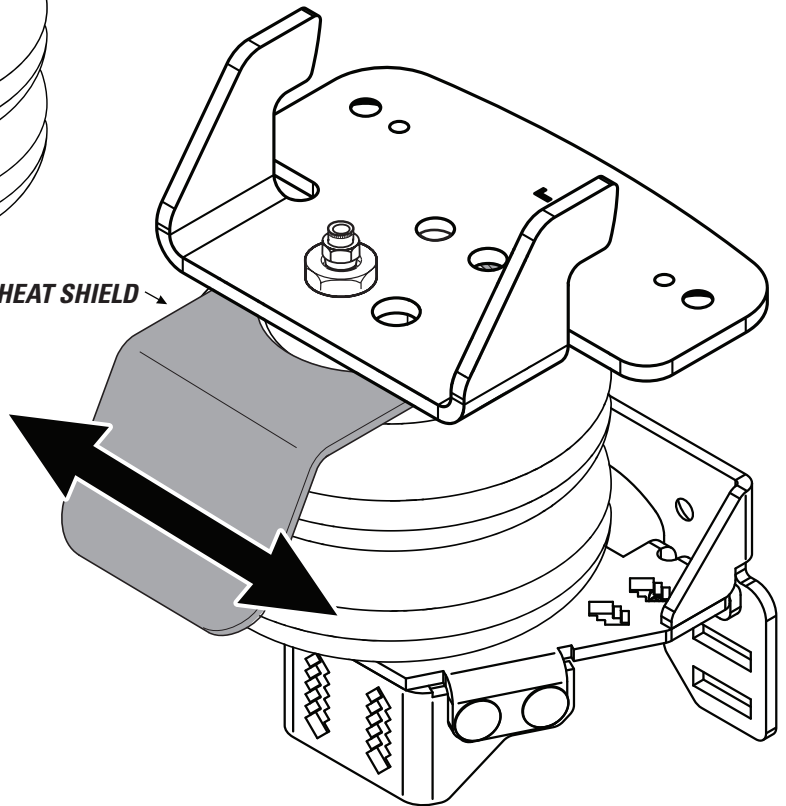

13

INSTALL INFLATION VALVES

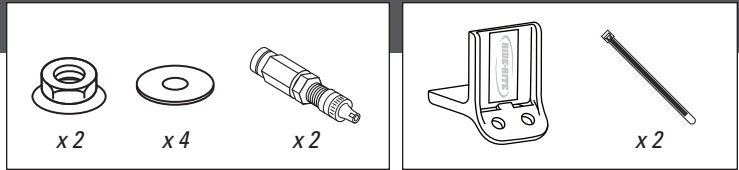

IF USING THE OPTIONAL NO-DRILL INFLATION VALVE BRACKET, CHOOSE OPTION 1. IF DRILLING, CHOOSE OPTION 2. **INFLATION VALVES MUST BE ACCESSIBLE BY AN AIR CHUCK.**

1 Secure the air inflation valve bracket to a protected, secure location.

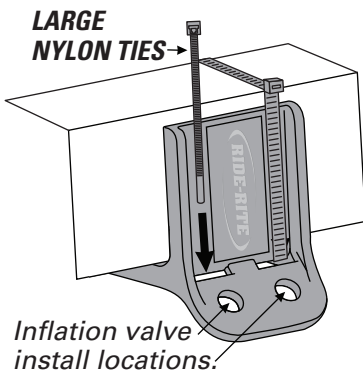

2 Select a protected location to install the inflation valves, such as the bumper or the body of the vehicle.

Drill two 5/16" holes for inflation valve install locations.

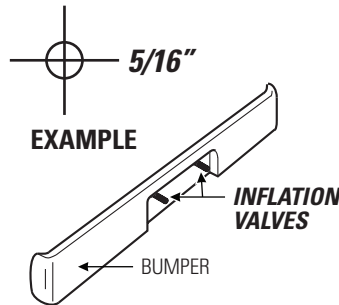

INFLATION VALVE ASSEMBLY

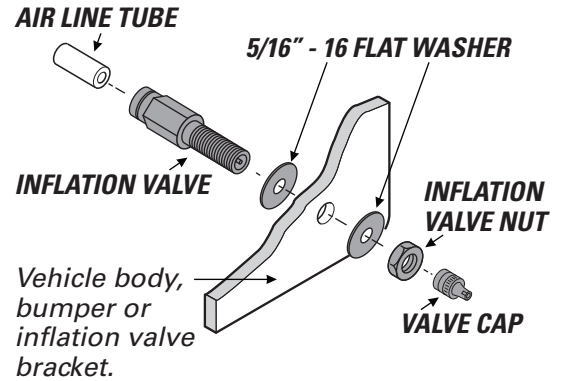

14

CUT THE AIR LINE TUBE INTO TWO EQUAL LENGTHS

1 Match air line tube ends.

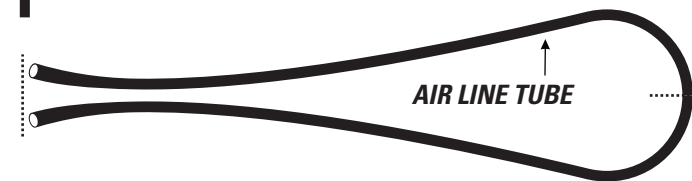

2 Find center of air line tube, make a square cut with tube cutter or sharp utility knife.

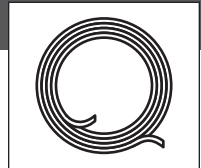

DO

Make sure the cut is as square as possible. Use a tube cutter or sharp utility knife.

DON'T

Fold or kink the air line tube. Cut the air line tube at an angle. Use pliers, scissors, snips, Saws, or side cutters.

PROPER AND IMPROPER CUTS IN THE AIR LINE TUBE

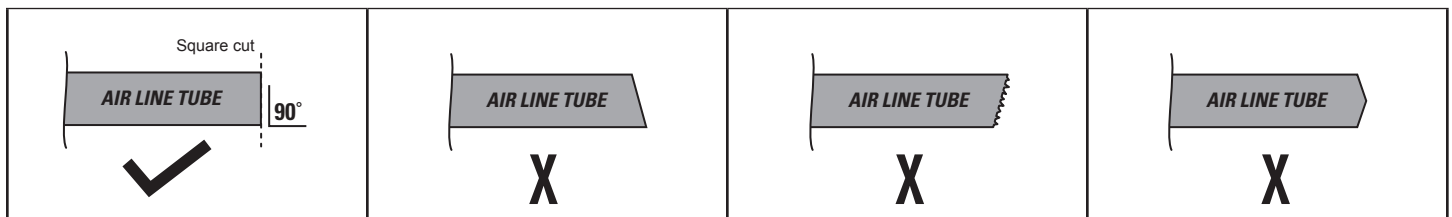

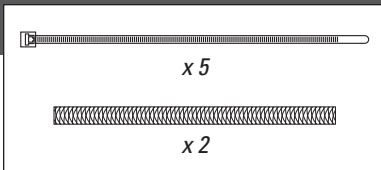

Air line tube routes will vary, depending on your truck, and requires you to choose the best path from the air springs to the inflation valves. Use the instructions below to help you choose.

DO

Select routes protected from heat, Debris, and sharp edges. Use thermal shields near heat sources. Use nylon ties to secure the air line tube.

DON'T

Bend or sharply curve air line tubes. Leave air line tube exposed to sharp edges. Use unnecessary lengths of air line tube. Route air line tube near moving parts. Let air line tube hang unsecured from vehicle. Scar air line tube while routing.

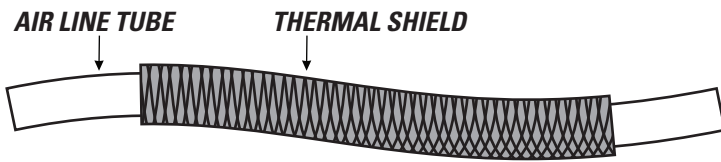

USE SUPPLIED THERMAL SHIELDS WHEN AIR LINE TUBE RUNS **WITHIN 6 INCHES** OF HEAT SOURCES.

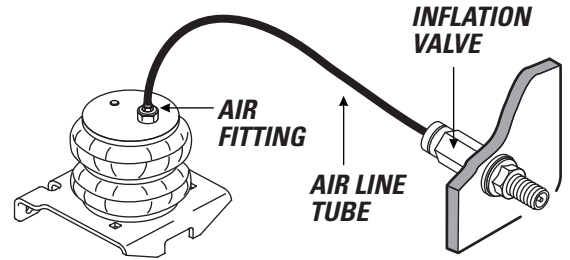

1 Insert end of air line tube into air fitting.

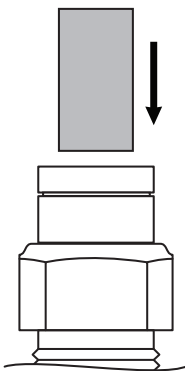

2 Push air line tube into air fitting as far as possible.

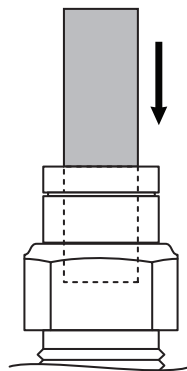

3 Gently pull on the air line tube to check for a secure fit.

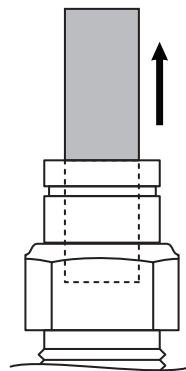

AIR LINE REMOVAL

To remove, push down collar and gently pull air line tube away.

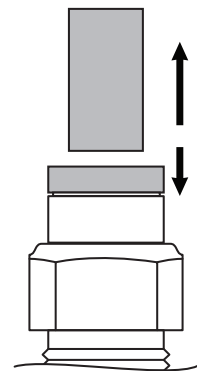

Removal Tip: Use a 1/4", 5/16", or 6mm open-ended wrench to push the collar down.

17

CHECKING THE AIR SYSTEM

- 1** Place an air chuck onto the inflation valve and fill the system to **70 PSI**.

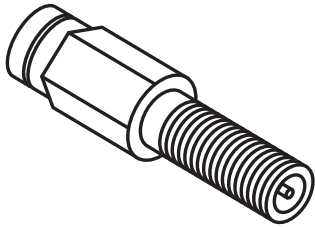

AIR SPRINGS INFLATE QUICKLY. CHECK AIR PRESSURE WHILE INFLATING.

- 2** Spray fittings with soap and water mixture or glass cleaner.



- 3** Observe bubbles.

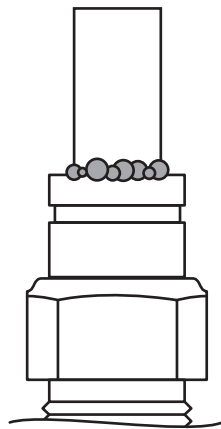

**SMALL SOAP BUBBLES
THAT DO NOT EXPAND**

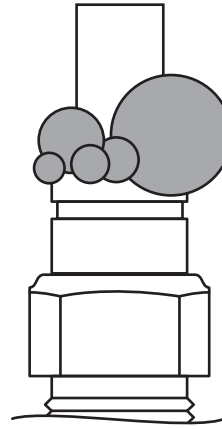

**SOAP BUBBLES
THAT EXPAND**



NO LEAKS?

Congratulations! Continue to step 18 to finish installation. Review the Operating Instructions.

LEAK?

Bummer. Continue to step 17 to fix the leak.

- 1** Press the air valve on end of inflation valve to release all air pressure.

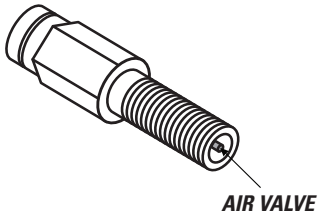

EXHAUST ALL AIR FROM THE SYSTEM PRIOR TO RELEASING AIR LINE TUBES FROM AIR FITTINGS.

LEAK AT AIR LINE TUBE AND AIR FITTING

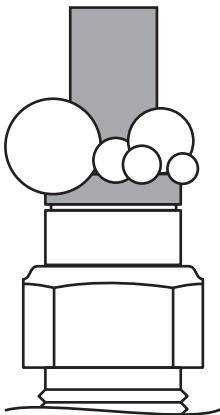

Release air line tube (see page 15). Review proper cuts and procedures in step 13. Repeat steps 15 and 16.

LEAK AT BASE OF AIR FITTING ON AIR SPRING

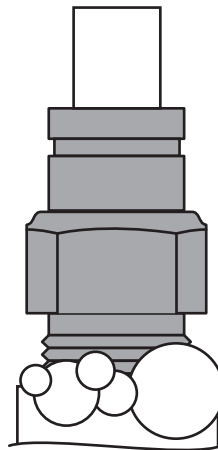

Tighten air fitting one turn or until leak stops.

LEAK OUT OF THE VALVE CORE ON INFLATION VALVE

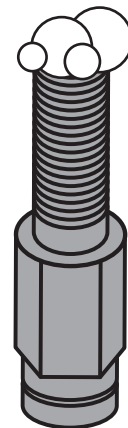

Tighten valve core with valve core wrench on inflation valve cap.

STILL HAVE A LEAK?

Refer to the Troubleshooting section of the Instruction Manual.

SAFELY RETURN VEHICLE TO OPERATIVE STATE

If you removed any wheels during installation, install the wheels and torque the lug nuts to the manufacturer's specifications.

Safely remove any jack stands and wheel chocks used during installation.

Re-attach the negative battery cable.

DOUBLE-CHECK AIR SPRING CLEARANCE

Check the air springs once again for the proper 1/2" minimum clearance. Perform clearance check again when vehicle is under load.

VEHICLE GVWR

NEVER exceed the maximum load recommended by the vehicle manufacturer (GVWR). The GVWR can be found in your vehicle's owner's manual or on the data plate on the driver's side door. Consult your local dealership for additional GVWR specifications.

READ AND UNDERSTAND THE OPERATING INSTRUCTIONS

The Ride-Rite system can improve handling and comfort. Take the time to learn how to properly use and maintain your investment by reading the Operating Instructions.



USE YOUR HAND TO CHECK FOR THE PROPER CLEARANCE AROUND THE AIR SPRING. IF YOUR HAND DOES NOT FIT BETWEEN THE AIR SPRING AND OTHER COMPONENTS, IT WILL RUB!

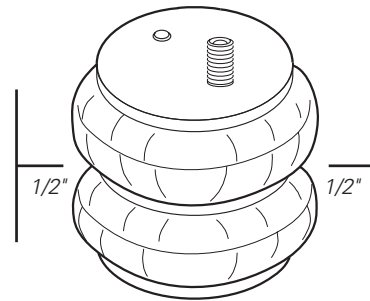

! IMPORTANT

A MINIMUM OF 5 PSI MUST BE MAINTAINED IN THE AIR SPRINGS AT ALL TIMES

Too much air pressure in the air springs will result in a firmer ride, while too little air pressure will allow the air springs to bottom out over rough conditions, and will not provide the improvement in handling that is possible.



MINIMUM PRESSURE



MAXIMUM PRESSURE (LOADED)

Firestone

AIRIDE

firestoneairide.com

BEFORE YOU DRIVE, CONFIRM THE FOLLOWING:

- Do you have a minimum of 5PSI in your air springs?
- Are your air springs standing 5 1/2" - 6 1/2" tall?
- Are your air springs properly aligned, left-to-right and front-to-back?
- Are your nuts and bolts tight?
- Put your paper work in your glove compartment for future reference.
- You've been bagged...and now your suspension is Airide™ equipped!

5 1/2" - 6 1/2"

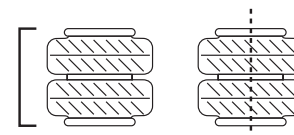

NEED INSTALLATION HELP? 1-800-888-0650

Select Option 1 for Airide; Select Option 1 for Technical Support.

Or, email us at rrtech@fsip.com. If emailing, please include photos to help us better diagnose and understand any problems you may be experiencing.

Firestone

Firestone Industrial Products

CONNECT WITH US



FirestoneIP



Firestone Airide

IMPORTANT

PLEASE DON'T HURT YOURSELF, THE KIT, OR YOUR VEHICLE. TAKE A MINUTE TO READ THIS IMPORTANT INFORMATION.

SAFE INSTALLATION

Please take all safety precautions during installation. A hydraulic jack can fail, and if that happens, you can be seriously hurt, or worse, if you are relying on it to hold up the vehicle. If you use a hydraulic jack, secure jack stands in the appropriate locations and chock any tires still touching the ground.

Wear safety glasses or goggles. Your eyes may be lower than some parts and pieces, and you don't want to lose an eye.

Remove the possibility of any electrical issues by disconnecting the negative battery cable.

VEHICLE GVWR

NEVER exceed the maximum load recommended by the vehicle manufacturer (GVWR). The GVWR can be found in your vehicle's owner's manual or on the data plate on the driver's side door. Consult your local dealership for additional GVWR specifications.

PRESSURE TO LOAD

Be sure to review the load limits noted in the air spring kit installation instructions (sold separately).

APPROPRIATE AIR PRESSURE

For best ride, use only enough air pressure in the air springs to level the vehicle when viewed from the side (front to rear). This will vary, depending on the load, location of the load, condition of the existing suspension, and personal preference.

ONCE INSTALLED SUCCESSFULLY, FOLLOW THESE PRESSURE REQUIREMENTS FOR THE AIR SPRINGS:

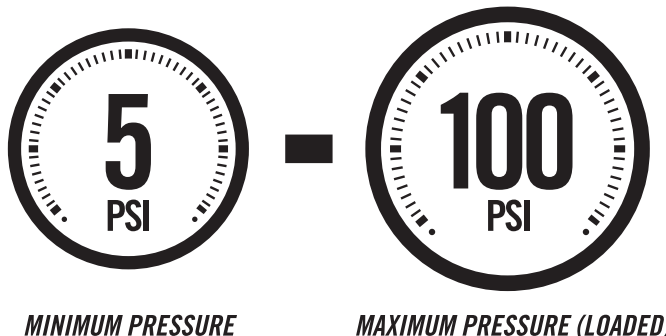



riderite.com

INSTALLATION INSTRUCTIONS

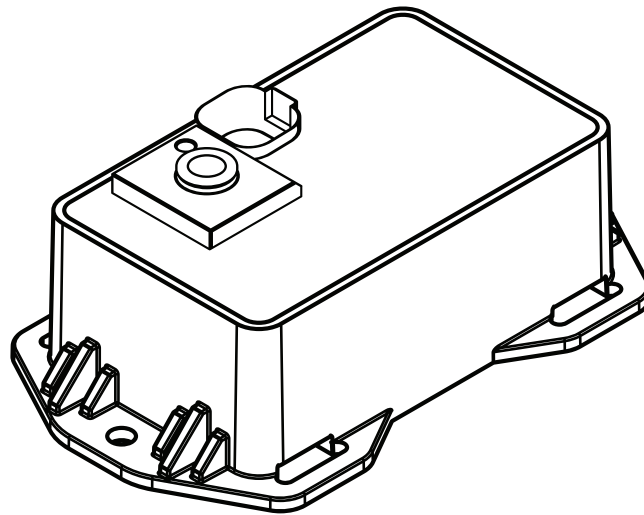



Firestone

Firestone Industrial Products

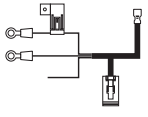
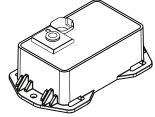
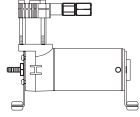

PARTS

Compare the parts below to your kit. Assure you have all pieces, and organize them for an easier installation.









MAIN KIT CONTENTS

PT # 9534	 x1 WIRE HARNESS	PT # 9535	 x1 ECU	PT # 9523	 x1 AIR COMPRESSOR KIT
				PT # 9414	 x1 AIR LINE TUBE (18 FEET)

A24-760-7560 INFLATION VALVE BRACKET KIT

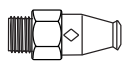
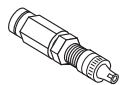
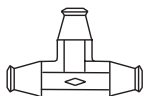
PT # 9483	 x1 NO-DRILL INFLATION VALVE BRACKET	PT # 9488	 x2 LARGE NYLON TIE
-----------	---	-----------	---

A21-760-2610 HARDWARE PACK

PT # 3087	 x4 10-32 x 1" MACHINE SCREW	PT # 3093	 x2 10-32 x 3/4" MACHINE SCREW	PT # 3086	 x10 3/16" FLAT WASHER
PT # 3088	 x6 10-32 NYLOCK NUT	PT # 3055	 x1 1/8 NPT PUSH-TO-CONNECT STRAIGHT FITTING	PT # 3032	 x1 INFLATION VALVE AND VALVE CAP ASSEMBLY
PT # 3025	 x3 1/4" PUSH-TO-CONNECT TEE	PT # 3421	 x1 10-16 x 3/4" SELF-TAPPING SCREW	PT # 9036	 x8 RED NYLON TIE
PT # 9488	 x2 LARGE NYLON TIE	PT # 0899	 x2 THERMAL SLEEVE		

CONTENTS AND OVERVIEW

- PAGE **4** **PLANNING THE INSTALL**

- PAGE **5** **PREPARE THE AIR COMPRESSOR**

- PAGE **6** **DRILL HOLES FOR AIR COMPRESSOR AND ECU**

- PAGE **7** **INSTALL THE AIR COMPRESSOR AND ECU**

- PAGE **8** **INSTALL THE WIRE HARNESS**

- PAGE **9** **INSTALL THE AIR LINE TUBES**

- PAGE **10** **OPTIONAL INFLATION VALVE INSTALLATION**

- PAGE **11** **INSTALL THE AIR FILTER AND CLEAN UP**

- PAGE **12** **CONNECTING TO THE APP**

- PAGE **13** **TEST THE SYSTEM**

- PAGE **14** **FIX AN AIR LEAK**

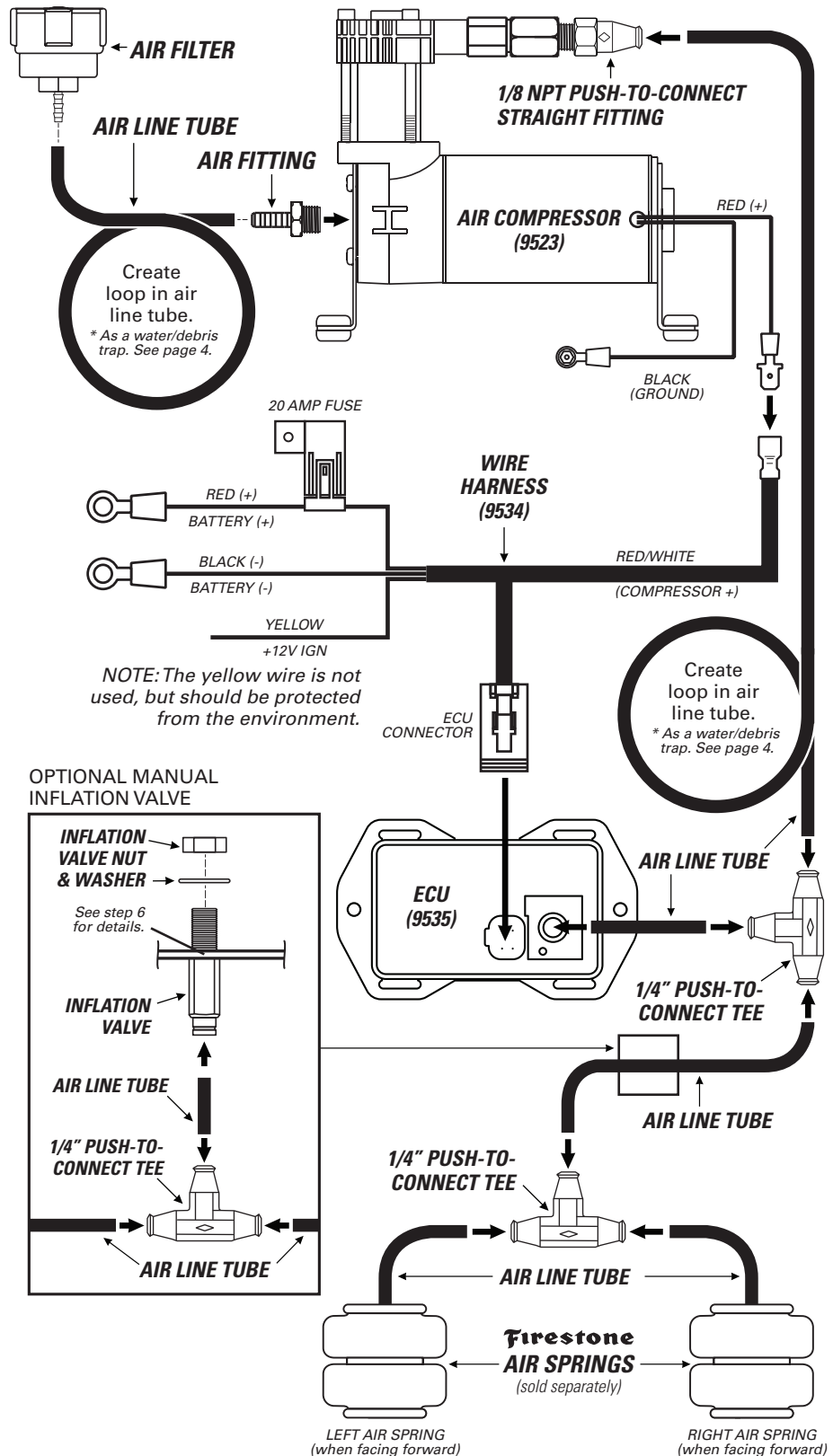

PLANNING THE INSTALL

THESE PLANNING STEPS WILL HELP YOU SAVE TIME AND WILL MAKE THE INSTALLATION EASIER.

DETERMINE THE MOUNTING LOCATION FOR THE AIR COMPRESSOR

- Provides ample air flow and is protected from airborne debris and moisture.
- Mount close enough to the ECU to allow wire harness connections to reach.
- If using the optional Firestone air accessory mounting kit, consider the guidelines above, and follow the kit's instructions.

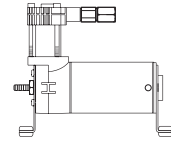

DETERMINE THE MOUNTING LOCATION FOR THE ECU

- Mount close enough to the air compressor to allow wire harness connections to reach.
- Allow room for air line tube to connect to the air fittings on the ECU.
- Allow room for the 4-pin ECU connector to connect to the ECU.
- Allow room for the air line tube to run without sharp curves or bends.
- Using supplied fasteners shown in step 3 is recommended. If no other mounting option is available, see the sidebar on step 2 for using the large Nylon ties.
- Select a location that is solid and secure on the body or frame of the vehicle, away from any moving parts, electrical or any other lines.

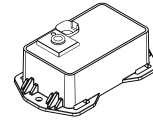

PLAN INSTALLATION ROUTES FOR WIRING AND AIR LINES

- Make sure the wire harness and air line tubes are not exposed to sharp metal edges that can damage them.
- Use supplied thermal sleeves on air line tubes when routing near heat sources.
- Use supplied Nylon ties to secure air line tubes and wire harness to the vehicle.
- Make a loop in the air line tube where shown. This creates a water/debris trap that protects the air compressor.
- Measure twice, cut once!

TAPE ALL ELECTRICAL CONNECTIONS

- Use electrical tape to appropriately secure and protect all electrical connections.

USING PUSH-TO-CONNECT FITTINGS FOR AIR LINES

Your kit includes push-to-connect fittings to connect the air line tubes to hardware. Use the instructions below when using the air line tubes.

- 1** Insert end of air line tube into air fitting.

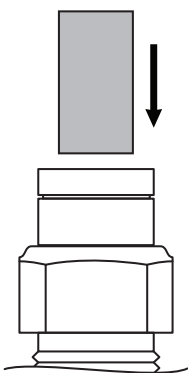

- 2** Push air line tube into air fitting as far as possible.

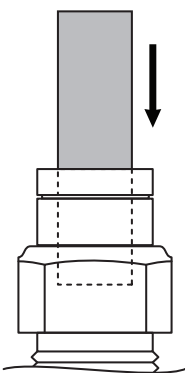

- 3** Gently pull on the air line tube to check for a secure fit.

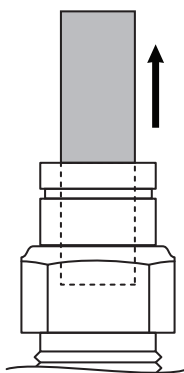

- 4** To remove, push down collar and gently pull air line tube away.

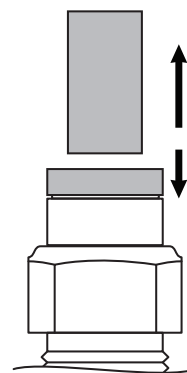

Removal Tip: Use a 1/4", 5/16", or 6mm open-ended wrench to push the collar down.

1

PREPARE THE AIR COMPRESSOR

NOTE: Air compressor can be mounted facing any direction.

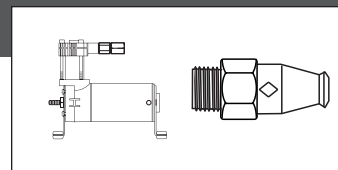

- 1 Install 1/8 NPT push-to-connect straight fitting on the check valve.

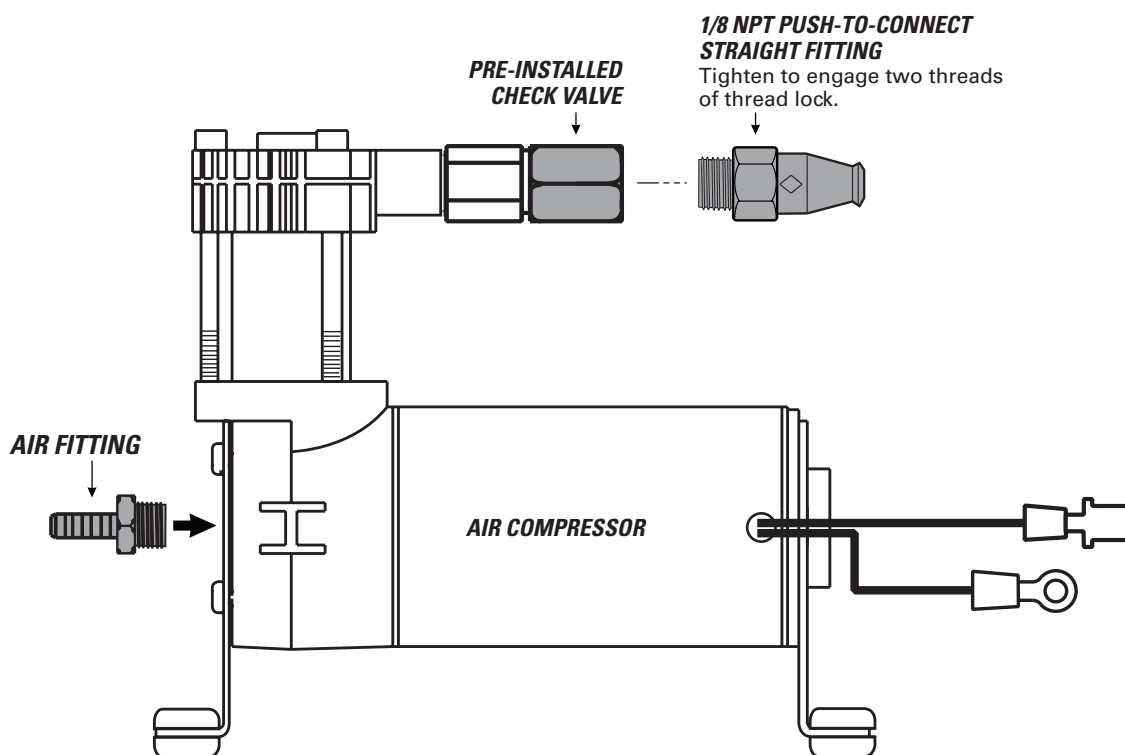

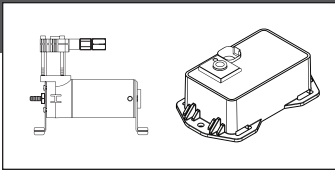

CHECK SURROUNDING AREA AND BACK SIDE OF MOUNTING LOCATION TO AVOID DRILLING INTO EXISTING LINES OR WIRING.



IF YOU ARE USING THE OPTIONAL FIRESTONE AIR ACCESSORY MOUNTING KIT, SKIP THIS STEP AND REFER TO THE MOUNTING KIT'S INSTRUCTIONS.

Drill within reach of the ground wire ring terminal on body or frame of vehicle. **AIR ACCESSORY MOUNTING KIT CANNOT BE USED AS A GROUNDING LOCATION FOR THE AIR COMPRESSOR.**

1 Using the air compressor and ECU as templates, mark drill locations as shown with a punch or marking tool.

2 Mark air compressor ground wire fastening location within reach of the ground wire ring terminal.

3 Drill 3/16" diameter holes. Remove any burrs and debris from drill holes.

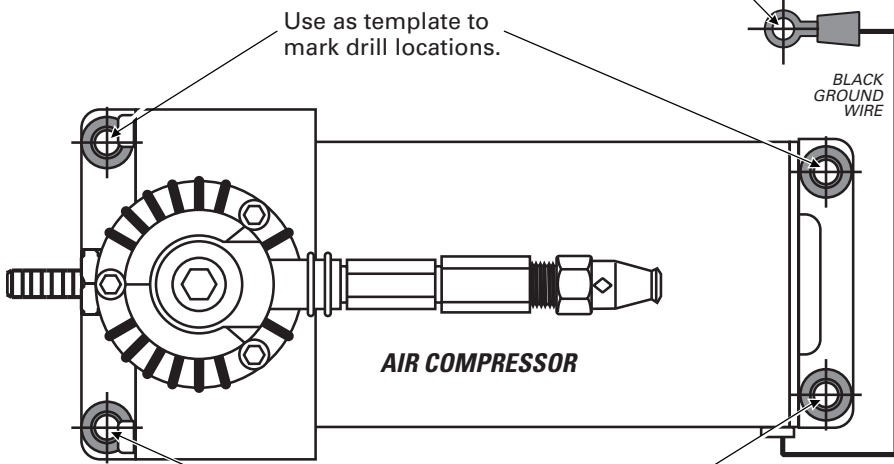

ASSURE THAT YOU INSTALL THE AIR COMPRESSOR AND ECU CLOSE ENOUGH SO THE CONNECTORS ON THE WIRE HARNESS WILL REACH THEM BOTH.

Use as template to mark drill locations.

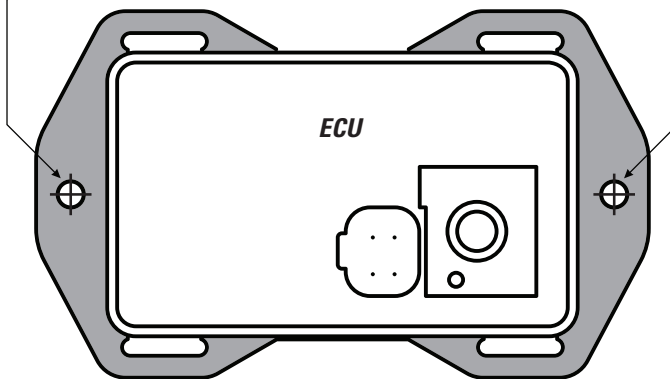

OPTIONAL ECU MOUNTING

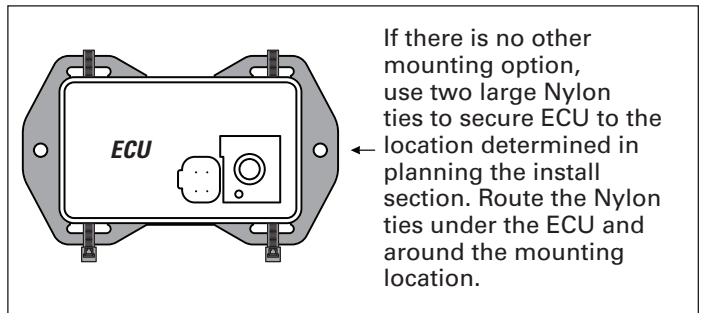

If there is no other mounting option, use two large Nylon ties to secure ECU to the location determined in planning the install section. Route the Nylon ties under the ECU and around the mounting location.

3

INSTALL THE AIR COMPRESSOR AND ECU

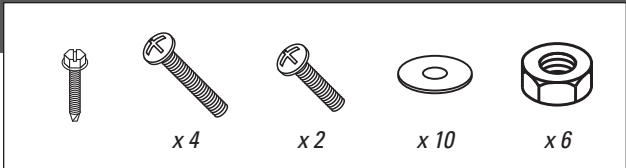

DO NOT OVER TIGHTEN MOUNTING BOLTS AND NUTS ON THE AIR COMPRESSOR. TOO MUCH TORQUE CAN CRUSH THE BRASS INSERTS AND RUBBER ISOLATORS.

1 Mount the air compressor to the drill hole location using the supplied fasteners. DO NOT OVERTIGHTEN.

2 Mount the ECU to the drill hole location using the supplied fasteners.

3 Mount the black ground wire ring terminal using the supplied fasteners. Assure that the ring terminal makes a solid contact with bare metal for a proper ground.

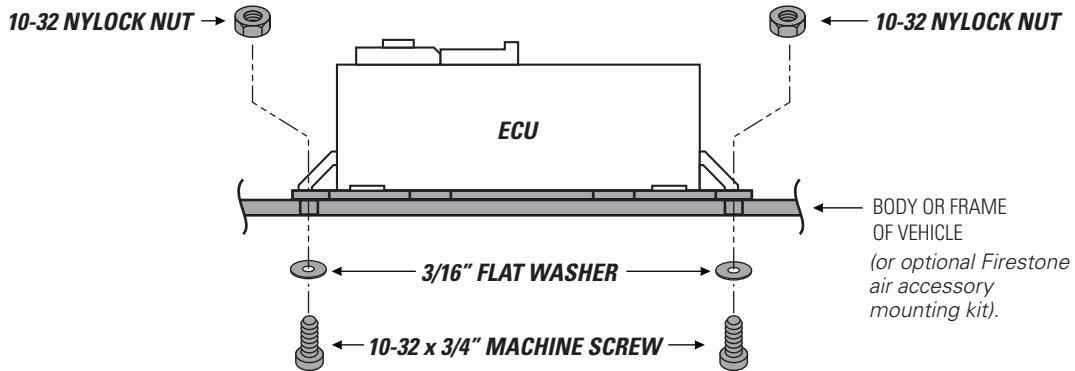
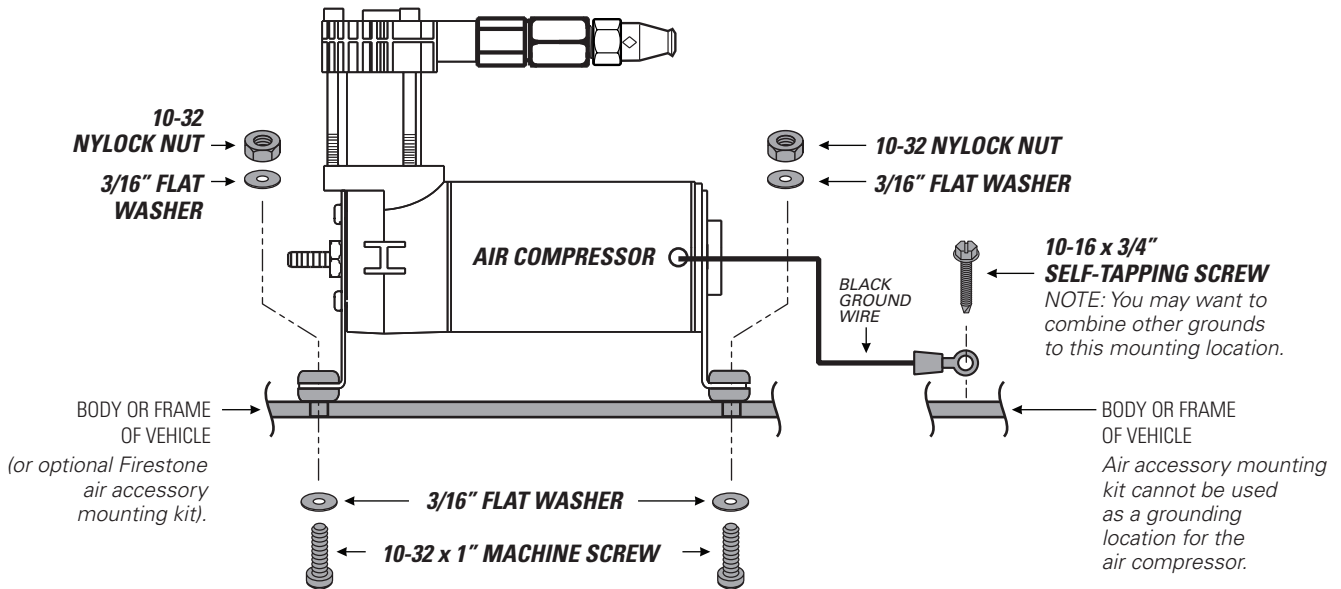

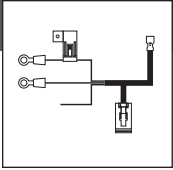

1 Route the wire harness in the most protected manner possible, and securely make all connections as shown.

2 The yellow wire is not used. Wrap or wire nut it to protect it from the environment.

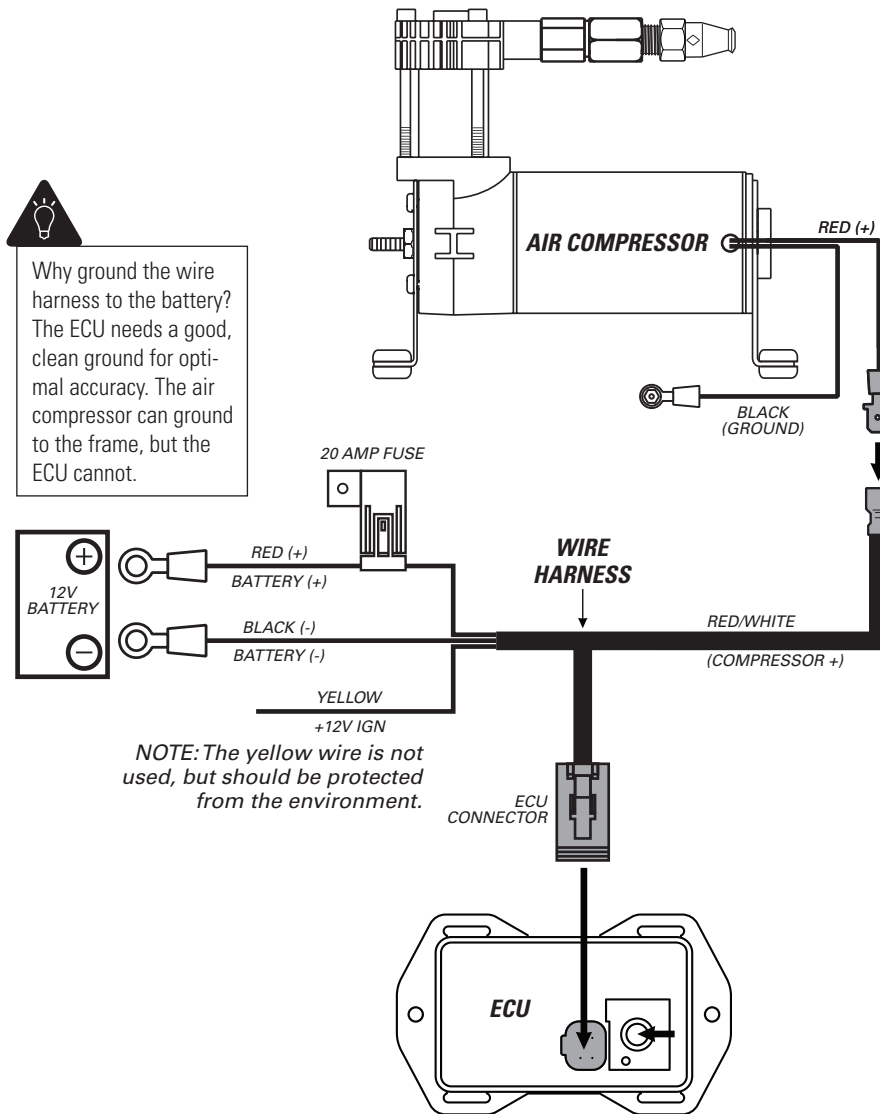

5

INSTALL AIR LINE TUBES



EXHAUST ALL AIR FROM THE SYSTEM PRIOR TO RELEASING AIR TUBES FROM AIR FITTINGS.

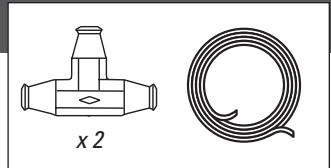

1 Route the air line tube from 1/8 NPT push-to-connect straight fitting on the top of the air compressor to the first 1/4" push-to-connect tee.

2 From the 1/4" push-to-connect tee, route air line tube to the ECU, as shown.

3 Route air line tube from each air spring and connect to a 1/4" push-to-connect tee, as shown.

4 Route air line tube to connect the two 1/4" push-to-connect tees, as shown.

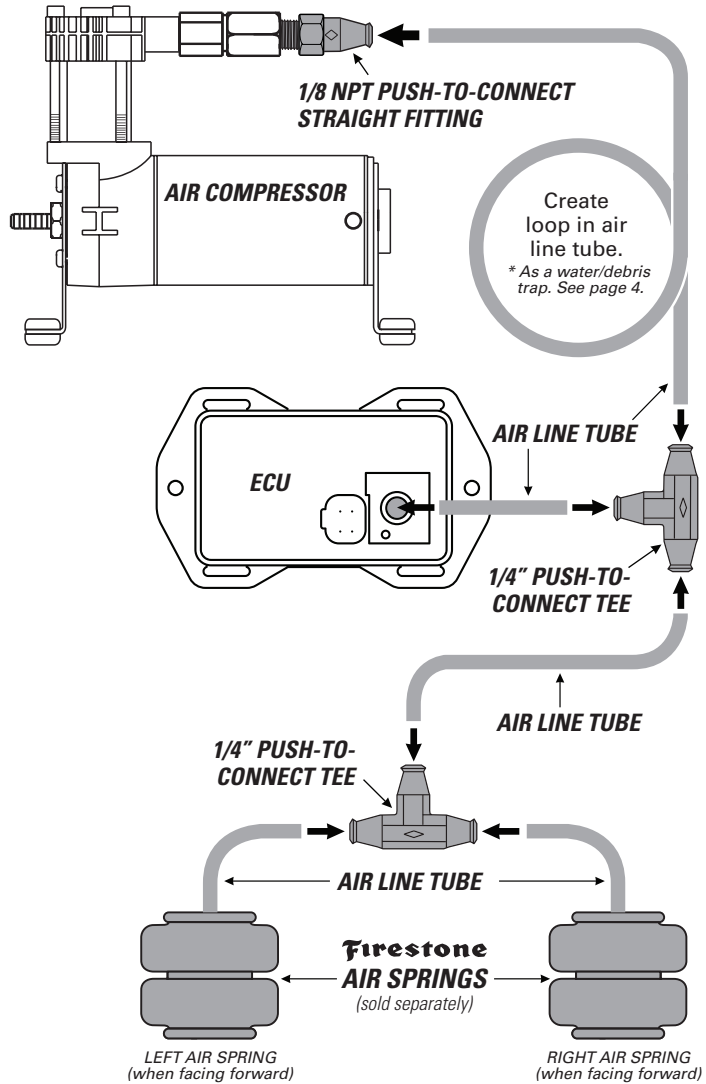

DO

Make sure the cut is as square as possible. Use a tube cutter or very sharp utility knife.

DON'T

Fold or kink the air line tube. Cut the air line tube at an angle. Use pliers, scissors, snips, saws, or side cutters.

PROPER AND IMPROPER CUTS IN THE AIR LINE TUBE

<p>Square cut</p> <p>AIR LINE TUBE</p> <p>90°</p>	<p>AIR LINE TUBE</p> <p>X</p>	<p>AIR LINE TUBE</p> <p>X</p>	<p>AIR LINE TUBE</p> <p>X</p>
---	-------------------------------	-------------------------------	-------------------------------

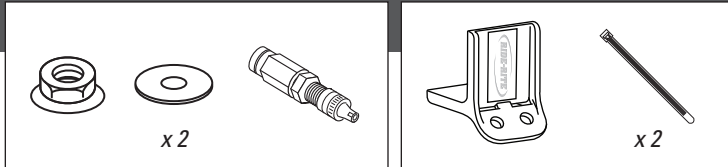

IF USING THE OPTIONAL NO-DRILL INFLATION VALVE BRACKET, CHOOSE OPTION 1. IF DRILLING, CHOOSE OPTION 2. **INFLATION VALVE MUST BE ACCESSIBLE BY AN AIR CHUCK.**

1 Secure the air inflation valve bracket to a protected, secure location. **PROCEED TO STEP 3.**

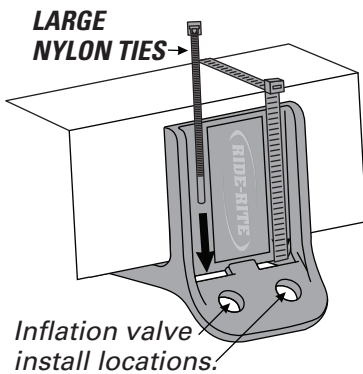

2 Select a protected location to install the inflation valve, such as the bumper or the body of the vehicle.

Drill a 5/16" hole for inflation valve install location.

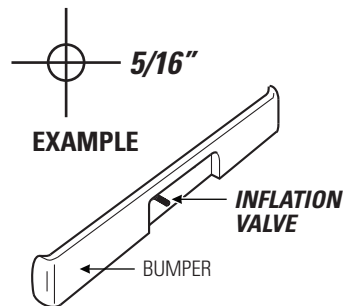

3 Install inflation valve assembly as shown.

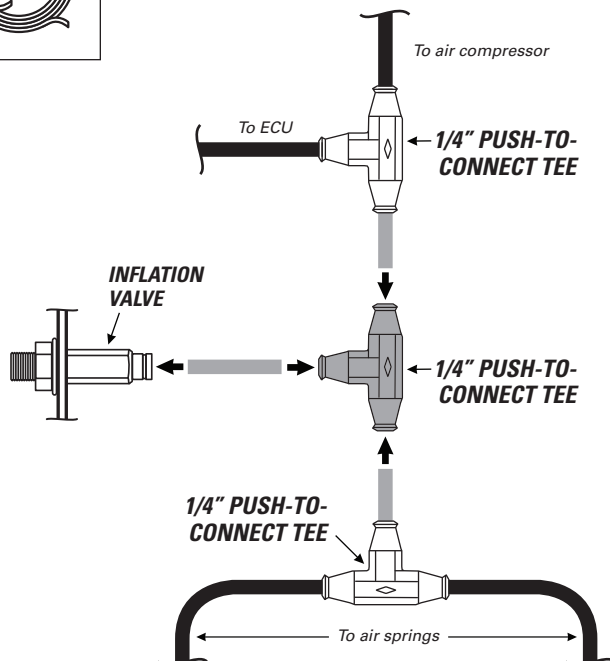
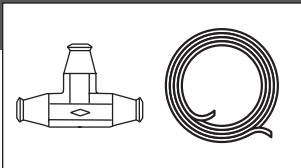
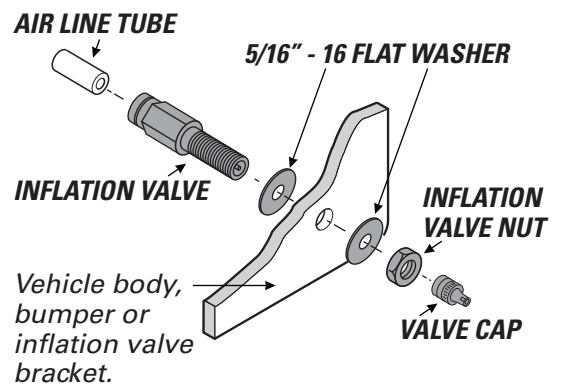

1 Run air line tube from the location of the installed inflation valve in step 7 to the air line tube that connects the two installed 1/4" push-to-connect tees.

2 Cut the piece of air line tube that connects the two installed 1/4" push-to-connect tees.

3 Install the air lines into the 1/4" push-to-connect tee, as shown.

4 Install the air line tube into the inflation valve, as shown.

8

INSTALLING THE AIR FILTER

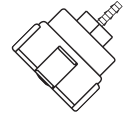

FILTER LIFE WILL VARY BASED ON ENVIRONMENTAL CONDITIONS. PROTECT THE AIR COMPRESSOR BY CHANGING THE AIR FILTER MORE FREQUENTLY IN DUSTY CONDITIONS.

1 Fully secure the air filter barb into the air line tube from the air compressor kit.

2 Press air line tube onto the barb on the air compressor air fitting until fully seated. Assure you create a loop in the air line tube, as shown, when securing it to the vehicle.

3 Periodically check the air filter during operation. When the air filter is dirty and needs to be replaced, contact an Authorized Firestone dealer to purchase a new one.



SECURE THE AIR FILTER IN A LOCATION THAT PROTECTS IT FROM MOISTURE AND DEBRIS, AND IS ABOVE THE LOOP IN THE AIR LINE TUBE.

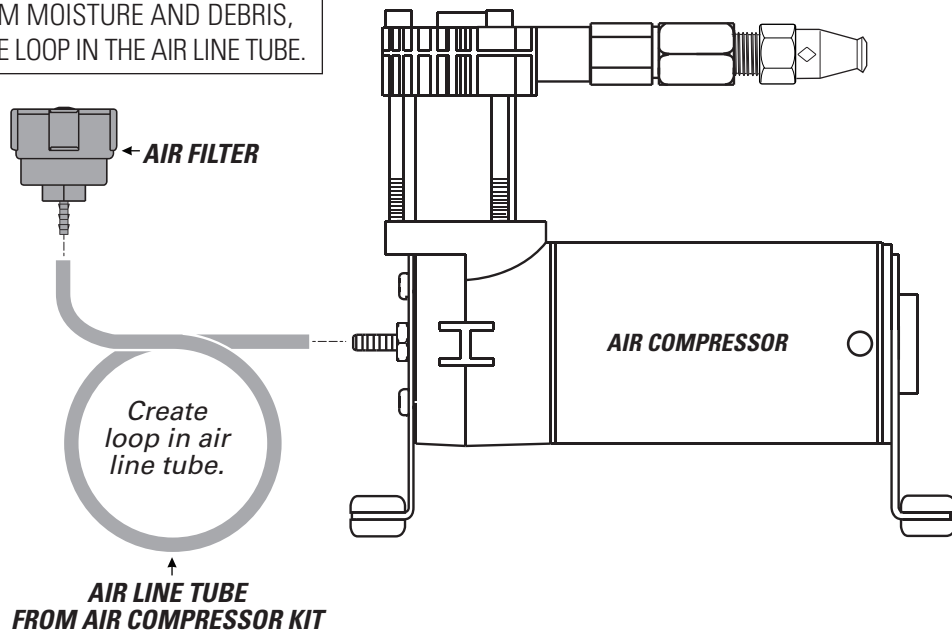

9

CLEAN UP INSTALLATION



1 Clean up the installation using supplied Nylon ties, and return all factory parts and materials to operative state.



USING SUPPLIED NYLON TIES, SECURE ALL WIRING AND AIR LINE TUBE IN A MANNER THAT DOES NOT OBSTRUCT MOVING PARTS OR IN ANY WAY THAT AFFECTS YOUR ABILITY TO SAFELY OPERATE THE VEHICLE.

1 Download and install the Firestone Air Command app on a compatible iPhone or Android device.

2 Open the app. Once the app has established a Bluetooth connection on startup, it will automatically link to the ECU.

MAIN APP SCREEN

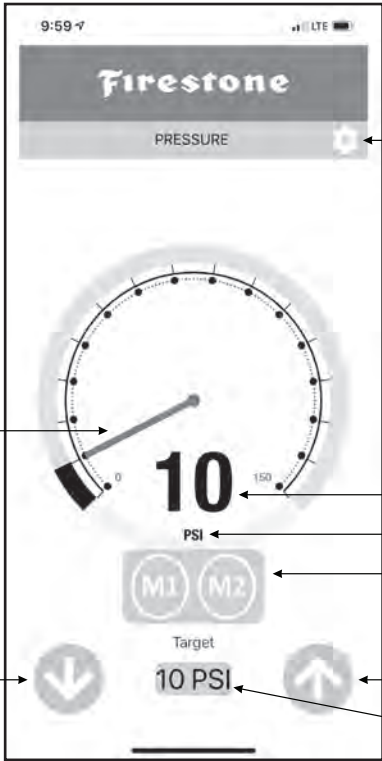

NEEDLE AND BAR
Shows actual pressure. Can be used to change pressure.

DECREASE PRESSURE

SETTINGS

ACTUAL PRESSURE

UNITS

MEMORY BUTTONS
To set memory, hold down target pressure, then press M1 or M2.

INCREASE PRESSURE

TARGET PRESSURE
Set by user.

SETTINGS

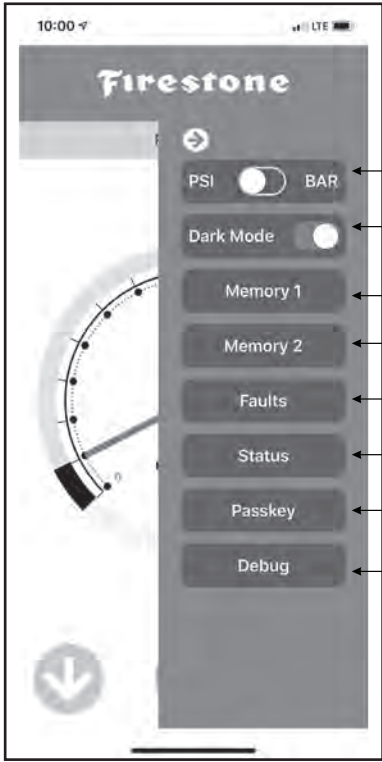

CHANGE UNITS

CHANGE DARK MODE
Auto adjust to ambient light for contrast.

SET AND NAME MEMORY 1

SET AND NAME MEMORY 2

SHOW FAULTS SCREEN

SHOW SYSTEM STATUS SCREEN

CHANGE PASSKEY
User set or default (123456).

SHOW LOG SCREEN FOR TROUBLESHOOTING

* Any faults will include troubleshooting instructions

11

TEST THE SYSTEM

With the Air Command™ F3 kit and your air springs installed, you are ready to test the system.

- 1 Reattach the negative battery cable.

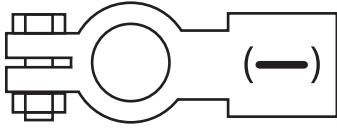

- 2 Turn on your vehicle's ignition.

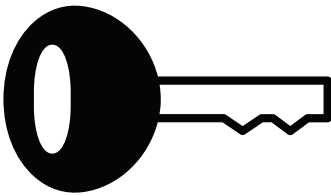

- 3 Use the app to inflate the air springs to 70 PSI. See step 10 for details.

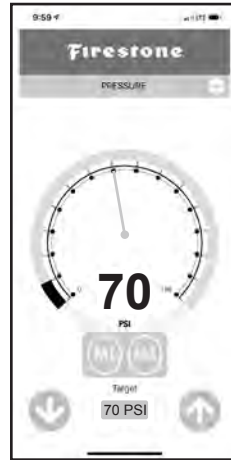

- 4 Spray fittings with soap and water mixture or glass cleaner.



- 5 Observe bubbles.

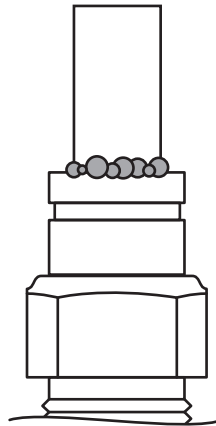

**SMALL SOAP BUBBLES
THAT DO NOT EXPAND**

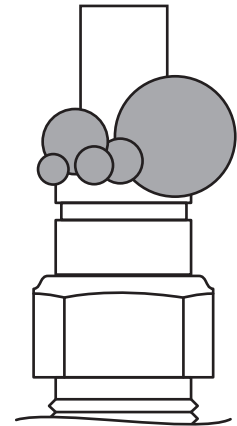

**SOAP BUBBLES
THAT EXPAND**



NO LEAKS?

Congratulations! You're riding right with the push of a button! Remember to review the Operating Instructions.

LEAK?

Bummer. Continue to step 12 to fix the leak.



EXHAUST ALL AIR FROM THE SYSTEM PRIOR TO RELEASING AIR TUBES FROM AIR FITTINGS.



- 1 Use the app to deflate the air springs to 5 PSI. See step 10 for details.

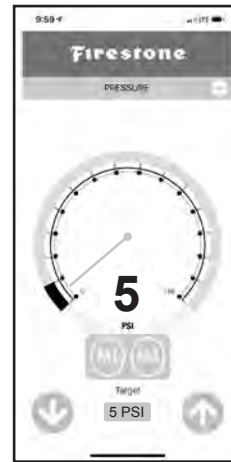

LEAK AT AIR LINE TUBE AND AIR FITTING

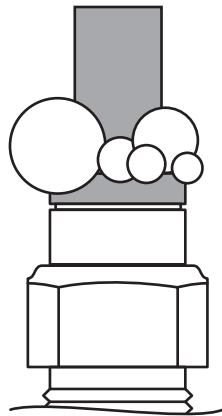

Release air line tube (see page 4). Review proper cuts and procedures in step 5. Repeat step 5.

LEAK AT BASE OF AIR FITTING

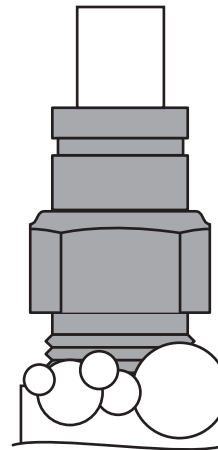

Tighten Air Fitting one turn or until leak stops.

STILL HAVE A LEAK?

Refer to the Troubleshooting section of the Instruction Manual. If the leak persists, or if there is an issue with a leaking part, call 1-800-888-0650; Option 1; Option 1 for Tech Support.



riderite.com

BEFORE YOU DRIVE, CONFIRM THE FOLLOWING:

- Secure all air line tubes and wiring.
- The system passes the leak test and holds air.
- The air compressor ground ring terminal is contacting bare metal, and coated with silicone if possible.
- The wire harness is grounded to the negative (-) battery terminal. The ECU needs a good, clean, interference-free ground.
- There is a loop in the air line tubes as shown to prevent water or debris from getting into the air compressor head and damaging it.

NEED INSTALLATION HELP? 1-800-888-0650

Select option 1 for Ride-Rite; Select option 1 for Technical Support.

Or, email us at rrtech@fsip.com. Please include photos to help us better diagnose and understand any problems you may be experiencing.

Firestone

Firestone Industrial Products

CONNECT WITH US



FirestoneIP



Firestone Ride-Rite