

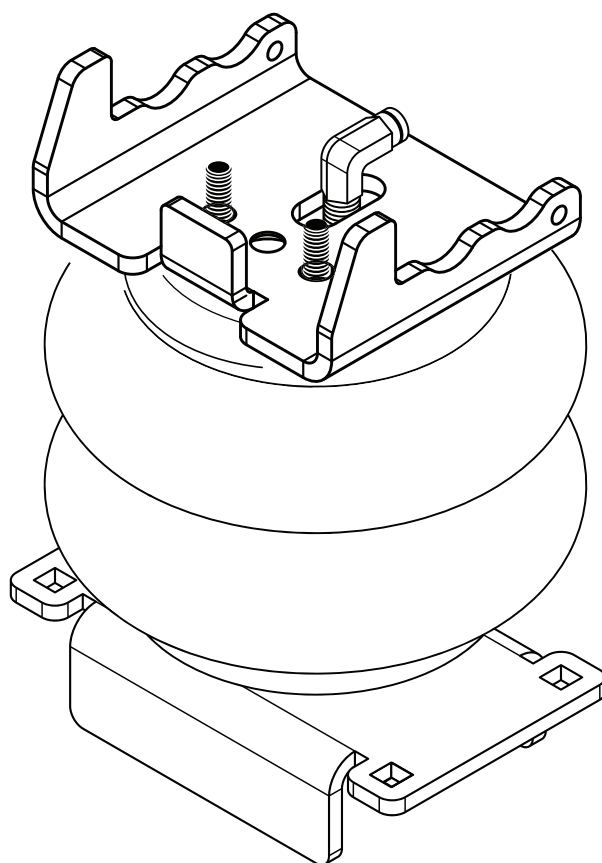

AIRIDE

firestoneairide.com

INSTALLATION INSTRUCTIONS



! IMPORTANT

PLEASE DON'T HURT YOURSELF, YOUR KIT OR YOUR VEHICLE. TAKE A MINUTE TO READ THIS IMPORTANT INFORMATION.

DO NOT INSTALL IF THE TRUCK HAS BEEN LIFTED AND THE STOCK JOUNCE BUMPER SPACERS ARE NOT ON THE VEHICLE. *This kit is to be used on a **pickup truck only**, and **DOES NOT INCREASE YOUR VEHICLE'S MAXIMUM LOAD.***

SAFE INSTALLATION

Please take all safety precautions during installation. A hydraulic jack can fail, and if that happens, you can be seriously hurt, or worse, if you are relying on it to hold up the vehicle. If you use a hydraulic jack, secure jack stands in the appropriate locations and chock any tires still touching the ground.

Wear safety glasses or goggles. Your eyes may be lower than some parts and pieces, and you don't want to lose an eye.

Remove the possibility of any electrical issues by disconnecting the negative battery cable.

KIT CLEARANCE

There must be a minimum of 1/2" clearance around all installed components when the air springs are inflated and under a load. The air springs must flex and expand during operation, so the clearance keeps the kit from rubbing against parts of the vehicle.

VEHICLE GVWR

NEVER exceed the maximum load recommended by the vehicle manufacturer (GVWR). The GVWR can be found in your vehicle's owner's manual or on the data plate on the driver's side door.

INFLATING THE AIR SPRINGS

When inflating air springs, add air pressure in small quantities, checking air pressure frequently. The air springs have much less air volume than a tire, so they inflate much more quickly.

PRESSURE TO LOAD

The air springs will support approximately 50 lbs. of load for each PSI of inflation pressure (per pair). For example, 50 PSI of inflation pressure will support a load of 1300 lbs. per pair of air springs.

APPROPRIATE AIR PRESSURE

For best ride, use only enough air pressure in the air springs to level the vehicle when viewed from the side (front to rear). This will vary, depending on the load, location of the load, condition of the existing suspension, and personal preference.

OPTIONAL T-FITTING

This kit includes inflation valves and air line tube for each air spring, allowing you to compensate for unbalanced loads. If you prefer a single inflation valve system to provide equal pressure to both air springs, your dealer can supply the optional "T" fitting (Part # 3025 or WRI-760-3461 retail pack).

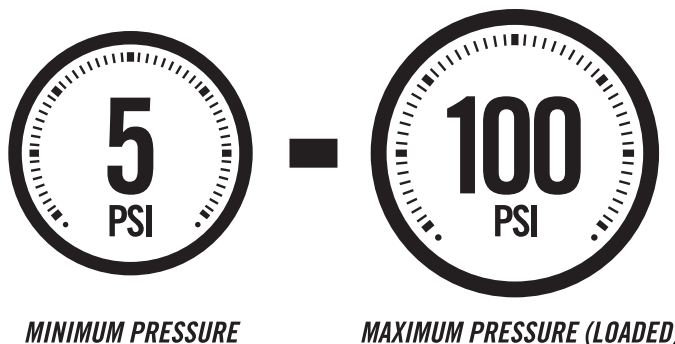

ONCE INSTALLED SUCCESSFULLY, FOLLOW THESE PRESSURE REQUIREMENTS FOR THE AIR SPRINGS:



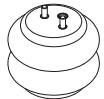
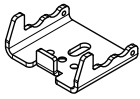
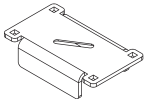
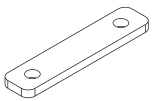

PARTS

Compare the parts below to your kit. Ensure you have all pieces, and organize them for an easier installation.









MAIN KIT CONTENTS

| | | | | | |
|-----------|--|-----------|--|-----------|--|
| PT # 6762 |  x2 AIR SPRING | PT # 5947 |  x2 UPPER BRACKET | PT # 5904 |  x2 LOWER BRACKET |
| PT # 5800 |  x4 BRACKET STRAP | PT # 1004 |  x1 HEAT SHIELD | PT # 9414 |  x1 RED AIR LINE TUBE (18 FEET) |

A24-760-7560 INFLATION VALVE BRACKET KIT

| | | | |
|-----------|---|-----------|---|
| PT # 9483 |  x1 NO-DRILL INFLATION VALVE BRACKET | PT # 9488 |  x2 LARGE NYLON TIE |
|-----------|---|-----------|---|

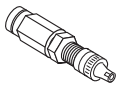
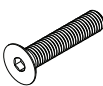
A21-760-2643 HARDWARE PACK

| | | | | | |
|-----------|---|-----------|--|-----------|---|
| PT # 3031 |  x2 AIR FITTING | PT # 3370 |  x2 3/8" - 16 x .75" FLAT HEAD SCREW | PT # 3481 |  x8 3/8" - 16 x 3" CARRIAGE BOLT |
| PT # 3033 |  x4 5/16" FLAT WASHER | PT # 3022 |  x12 3/8" - 16 FLANGE LOCK NUT | PT # 9036 |  x6 RED NYLON TIE |
| PT # 3032 |  x2 INFLATION VALVE AND VALVE CAP ASSEMBLY | PT # 3358 |  x2 M10 x 1.5 x 50MM FLAT HEAD SCREW | PT # 0899 |  x2 THERMAL SLEEVE |

CONTENTS AND OVERVIEW

PAGE 4 REMOVE JOUNCE BUMPER & INSTALL UPPER BRACKET

PAGE 5 INSTALL AIR FITTING AND LOWER BRACKET

PAGE 6 DRY FIT AIR SPRING AND LOWER BRACKET

PAGE 7 FASTEN AIR SPRING ASSEMBLY TO UPPER BRACKET

PAGE 8 SECURE LOWER BRACKET TO VEHICLE

PAGE 9 INSTALL THE HEAT SHIELD

PAGE 10 AIR LINE TUBE & INFLATION VALVE INSTALLATION

PAGE 11 INSTALL & ROUTE AIR LINE TUBE

PAGE 12 CHECKING THE SYSTEM

PAGE 13 FIXING AN AIR LEAK

PAGE 14 FINISHING THE INSTALLATION

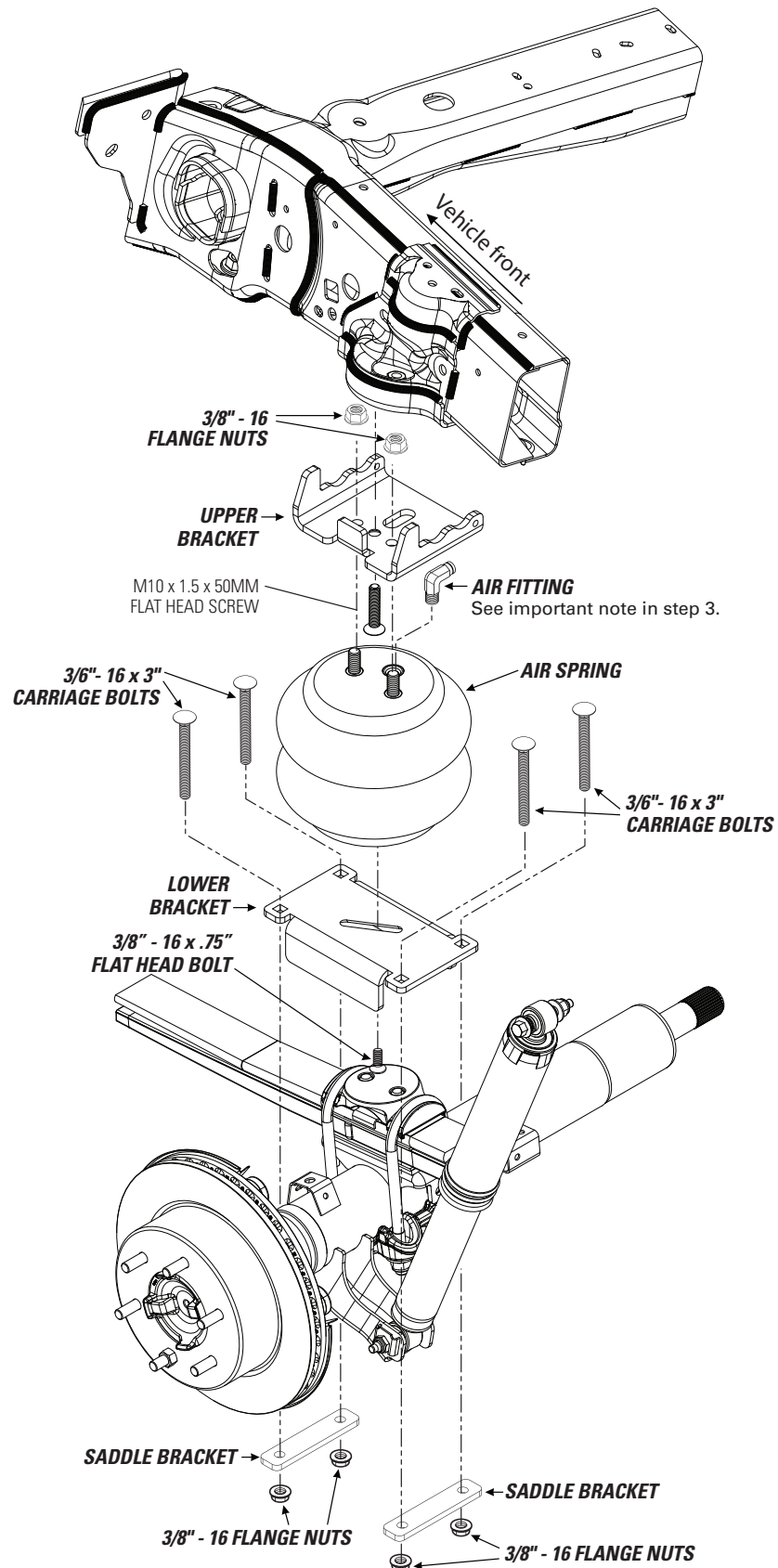

REMOVE JOUNCE BUMPER

1



START THE INSTALLATION ON THE LEFT SIDE OF THE VEHICLE WHEN FACING FORWARD.

1 Remove jounce bumper bolt.

2 Remove jounce bumper and cup.

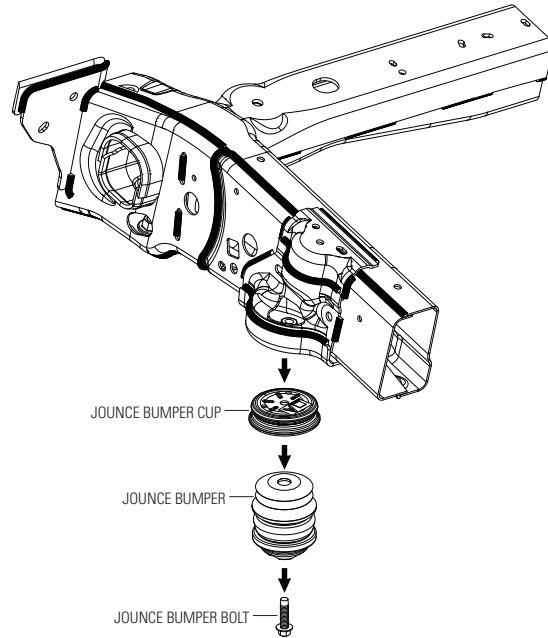

INSTALL UPPER BRACKET

2

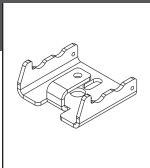

1 Use the 50mm flat head screw to fasten the upper bracket to vehicle frame.

2 Tighten bolt to factory specifications.

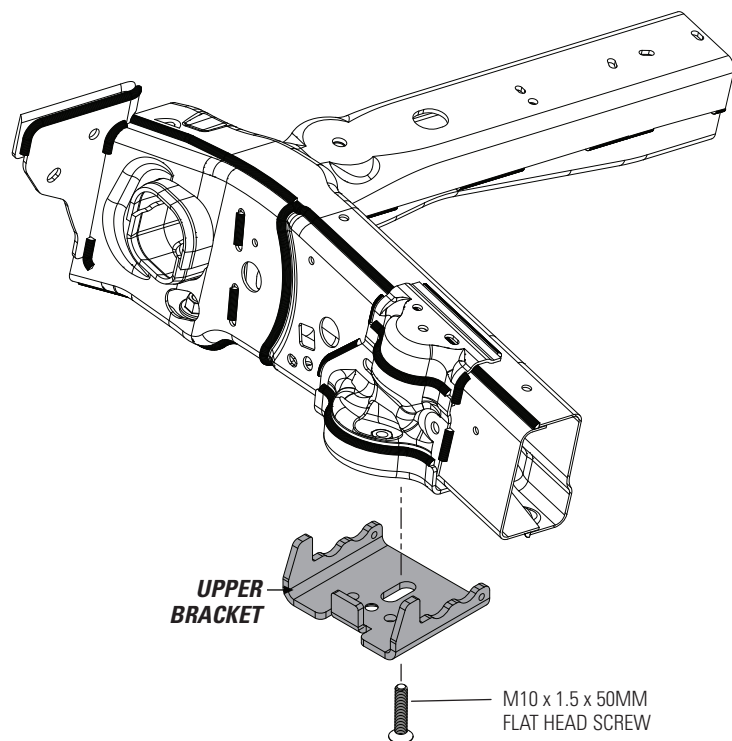

3

INSTALL AIR FITTING AND LOWER BRACKET

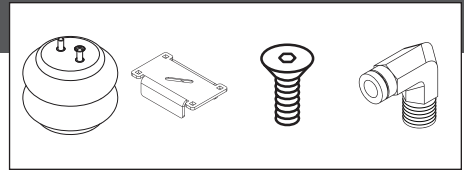

1 Thread air fitting to top of air spring. Tighten until two threads of threadlock are engaged and the air fitting is perpendicular to the air spring studs, as shown.

2 Fasten the lower bracket to the air spring, as shown. **DO NOT FULLY TIGHTEN THE FASTENER AT THIS STAGE.**

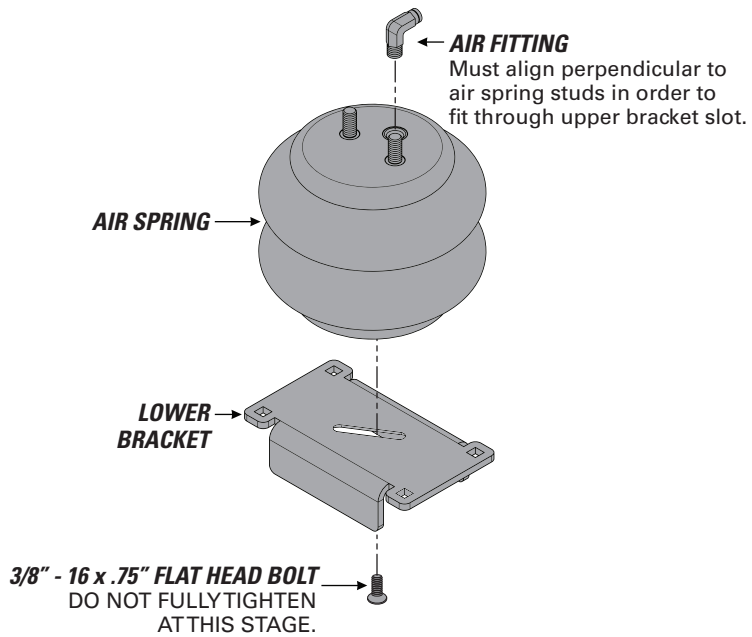
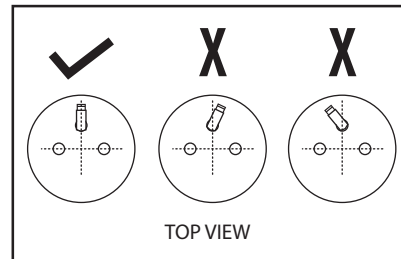

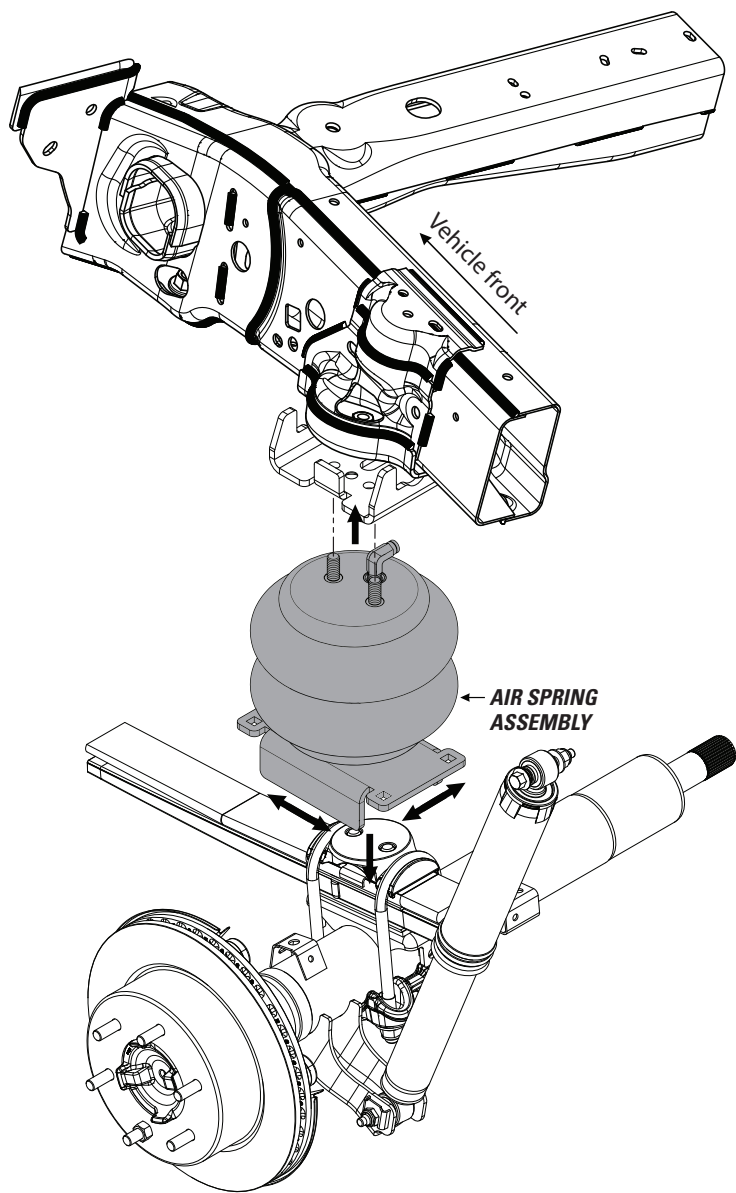

1 Temporarily insert the air spring threaded studs into the upper bracket. **DO NOT ATTACH NUTS TO THE AIR SPRINGS STUDS AT THIS STAGE.**

2 Slide and rotate the lower bracket for best alignment over the jounce bumper plate on the vehicle. Note that the bracket may be rotated 180 degrees, if necessary.

3 Make matching alignment marks on the bottom of the air spring and the lower bracket, as shown below.

DRY FIT ALIGNMENT

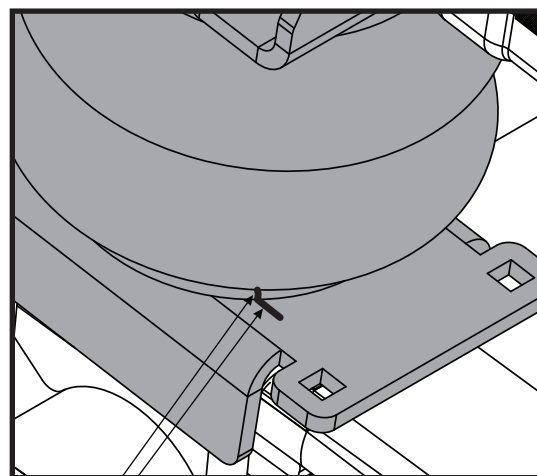

MAKE ALIGNMENT MARKS

SIDE VIEW

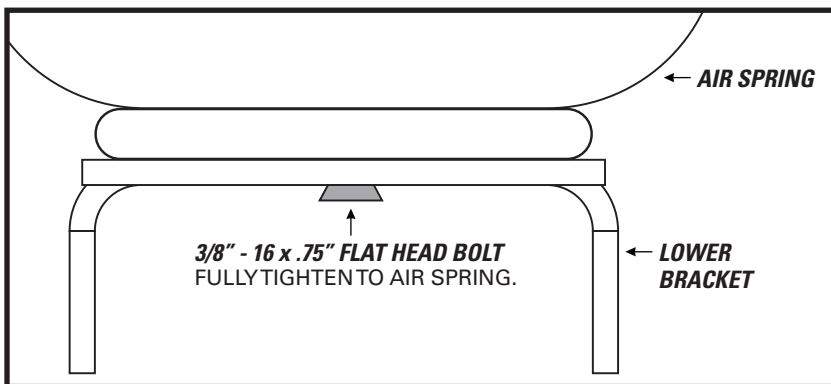

4 Remove air spring assembly. Align the marks you made, then **fully tighten the flat head bolt to the bottom of the air spring.**

5

FASTEN AIR SPRING ASSEMBLY TO UPPER BRACKET



x 2

1 Install air spring threaded studs into holes in upper bracket.

2 Secure the air spring to the upper bracket using the 3/8" - 16 flange nuts, as shown.



INSTALLING THE RIGHT SIDE? REMEMBER TO INSTALL THE HEAT SHIELD IN STEP 7 FIRST!

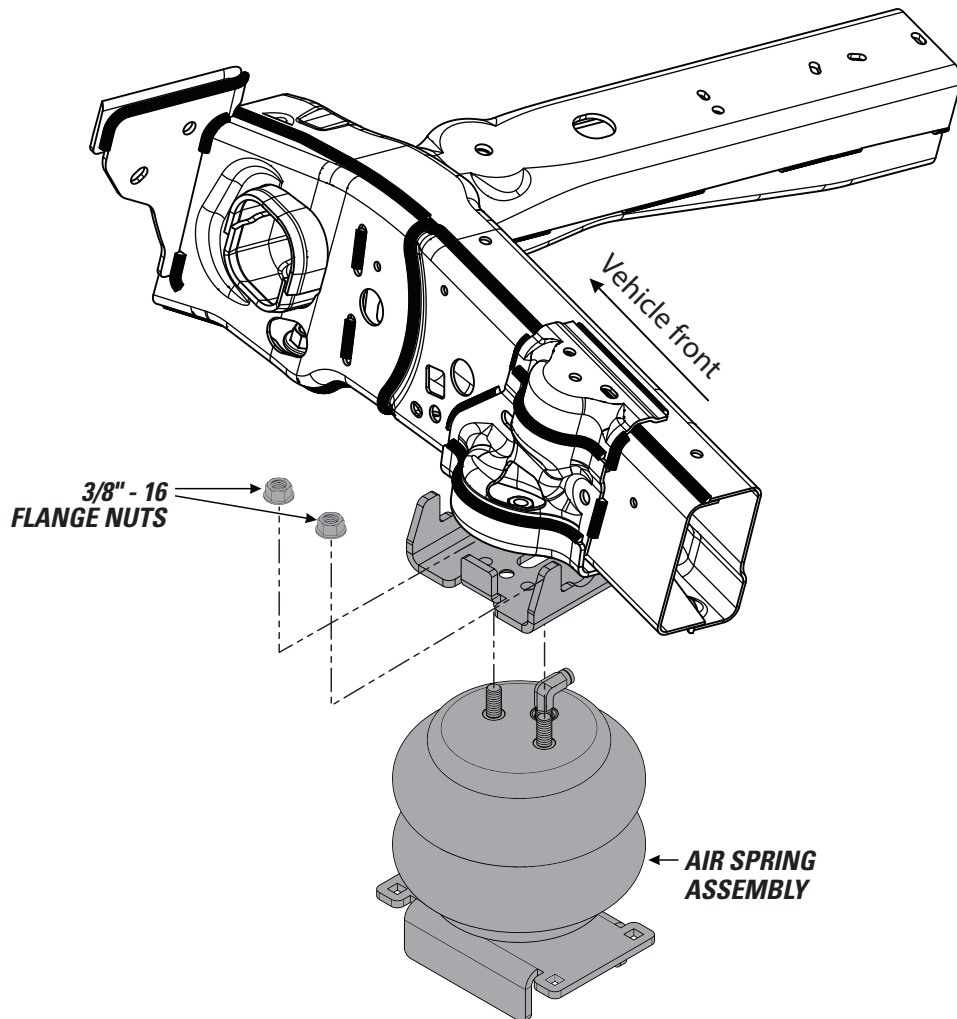

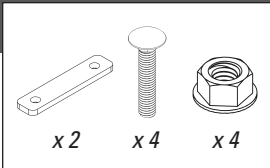

1 Use carriage bolts and bracket straps to attach the lower bracket to the vehicle leaf springs. Do not fully tighten yet.

2 Make sure bracket straps tightly contact to the bottom of the leaf springs and the side of the spring perch.

3 Fully tighten all fasteners.

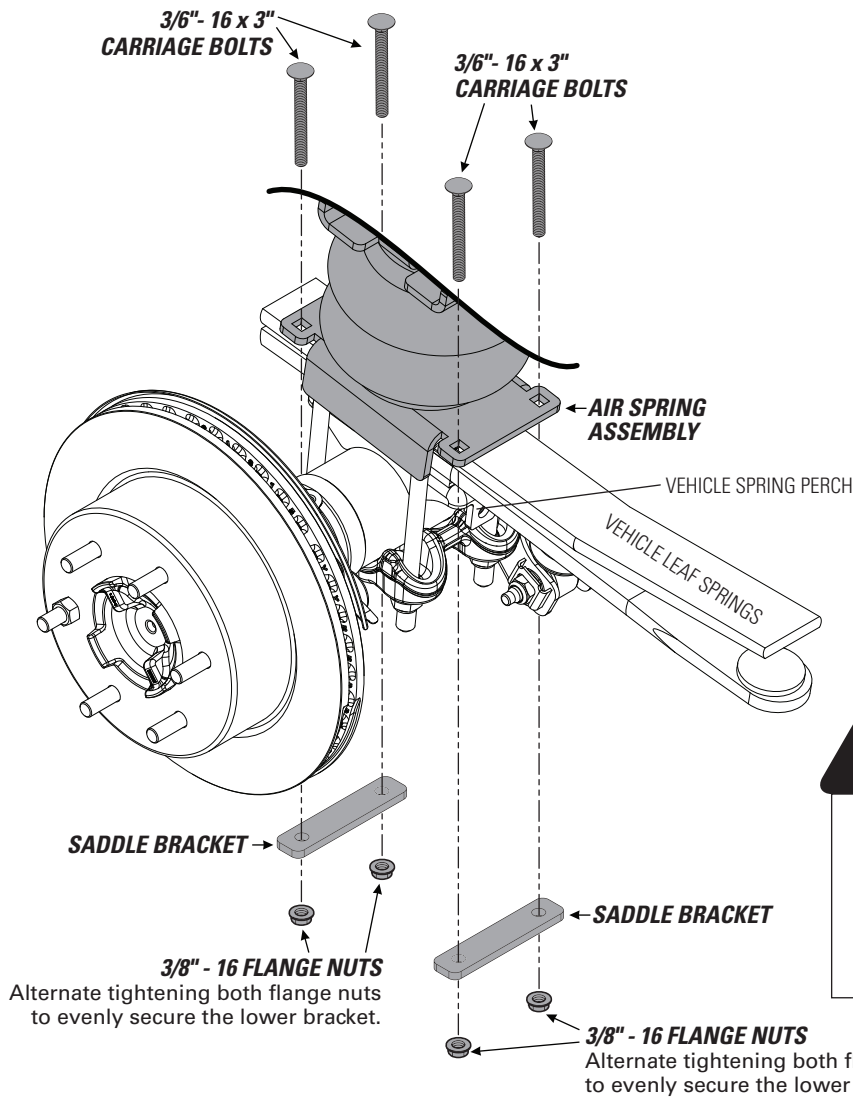

SIDE VIEW

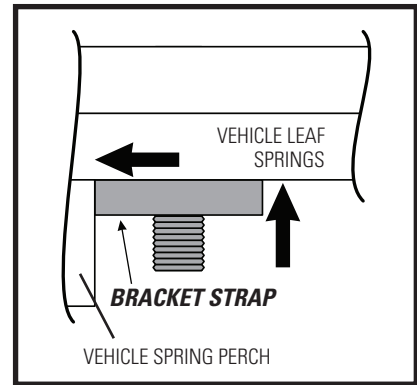

USE YOUR HAND TO CHECK FOR THE PROPER CLEARANCE AROUND THE AIR SPRING. IF YOUR HAND DOES NOT FIT BETWEEN THE AIR SPRING AND OTHER COMPONENTS, IT WILL RUB!



AWESOME! You're done with the left side. Go back to step 1 and repeat the steps for the right side installation, including step 7.

7

INSTALL THE HEAT SHIELD

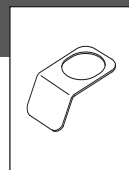

1 On the right side only, secure the heat shield by clamping it between the air spring and upper spring mount assembly.

2 Continue to step 6 to complete the right side installation.



THE HEAT SHIELD IS INSTALLED ON THE RIGHT SIDE OF THE VEHICLE ONLY!

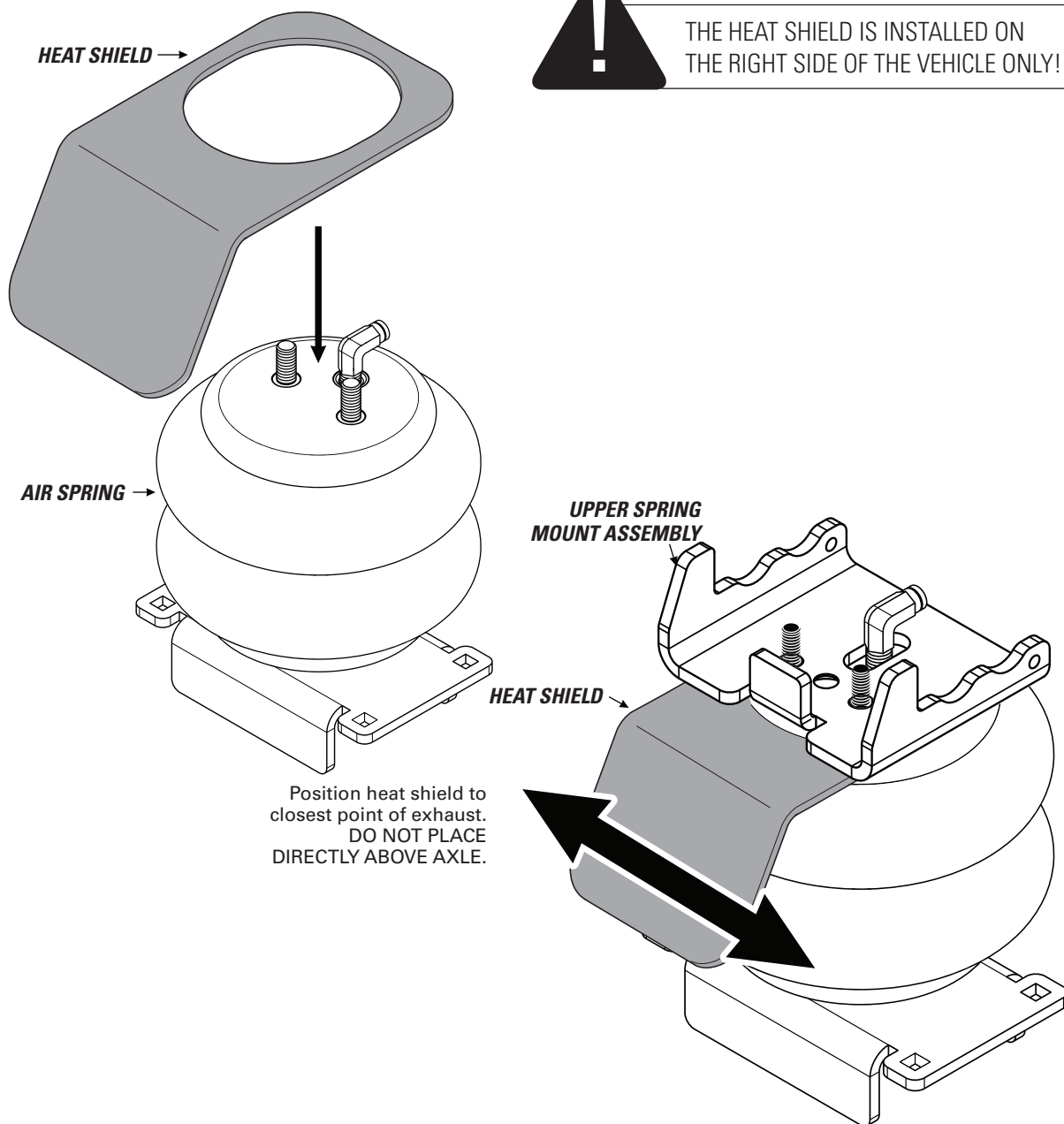

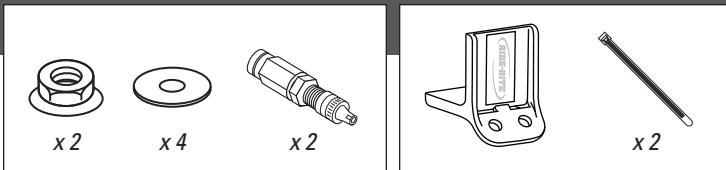

IF USING THE OPTIONAL NO-DRILL INFLATION VALVE BRACKET, CHOOSE OPTION 1. IF DRILLING, CHOOSE OPTION 2. **INFLATION VALVES MUST BE ACCESSIBLE BY AN AIR CHUCK.**

1 Secure the air inflation valve bracket to a protected, secure location. **PROCEED TO STEP 3.**

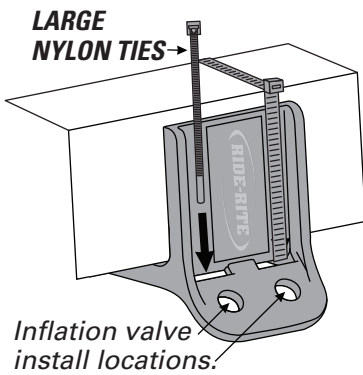

2 Select a protected location to install the inflation valves, such as the bumper or the body of the vehicle.

Drill two 5/16" holes for Inflation Valve install locations.

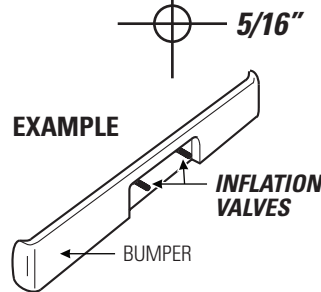

3 Install inflation valve assembly as shown.

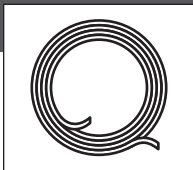
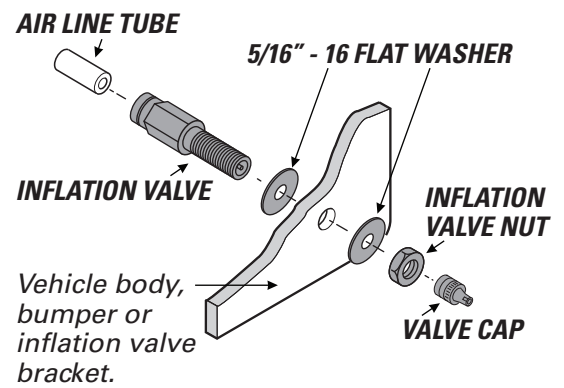

1 Match air line tube ends.



2 Find center of air line tube, make a square cut with tube cutter or sharp utility knife.

DO

Make sure the cut is as square as possible. Use a tube cutter or sharp utility knife.

DON'T

Fold or kink the air line tube. Cut the air line tube at an angle. Use pliers, scissors, snips, saws, or side cutters.

PROPER AND IMPROPER CUTS IN THE AIR LINE TUBE

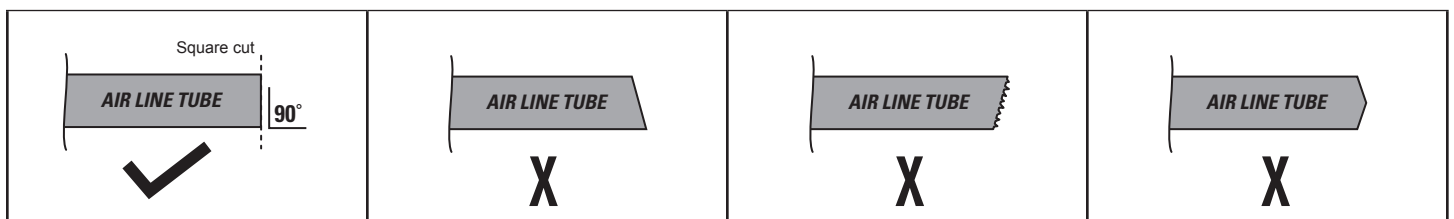

10

INSTALLING AIR LINE TUBE INTO AIR FITTINGS AND INFLATION VALVE

1 Insert end of air line tube into air fitting.

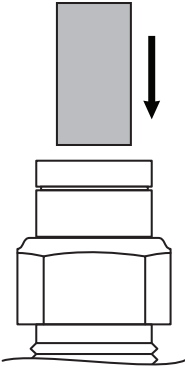

2 Push air line tube into air fitting as far as possible.

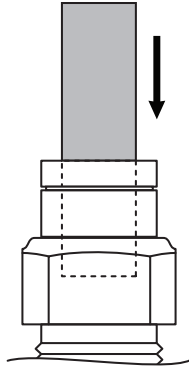

3 Gently pull on the air line tube to check for a secure fit.

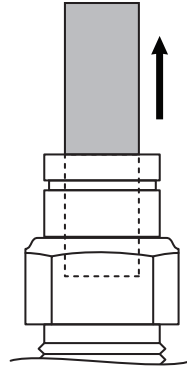

4 To remove, push down collar and gently pull air line tube away.

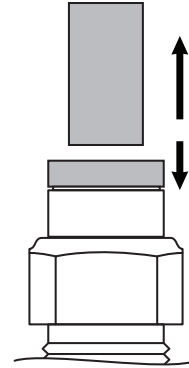

Removal Tip: Use a 1/4", 5/16", or 6mm open-ended wrench to push the collar down.

11

ROUTE AND SECURE AIR LINE TUBES

Air line tube routes will vary, depending on your truck, and requires you to choose the best path from the air springs to the inflation valves. Use the instructions below to help you choose.

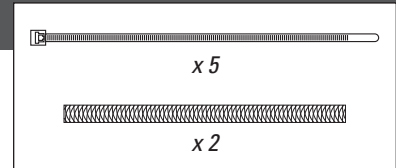

DO

Select routes protected from heat, debris, and sharp edges. Use thermal shields near heat sources. Use Nylon ties to secure the air line tube.

DON'T

Bend or sharply curve air line tubes. Leave air line tube exposed to sharp edges. Use unnecessary lengths of air line tube. Route air line tube near moving parts. Let air line tube hang unsecured from vehicle. Scar air line tube while routing.

AIR LINE TUBE THERMAL SHIELD

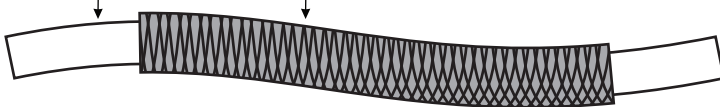

USE SUPPLIED THERMAL SHIELDS WHEN AIR LINE TUBE RUNS **WITHIN 6 INCHES** OF HEAT SOURCES.

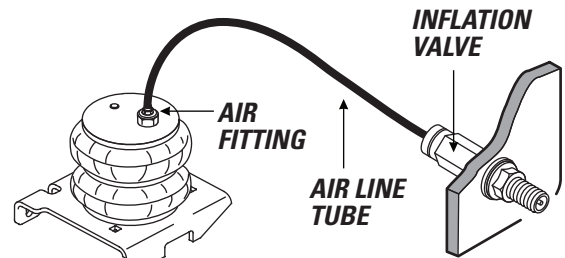

- 1** Place an air chuck onto the inflation valve and fill the system to **70 PSI**.

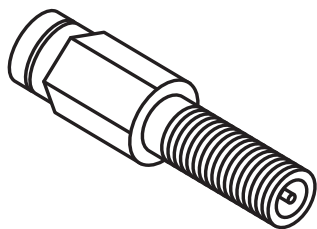

AIR SPRINGS INFLATE QUICKLY. CHECK AIR PRESSURE WHILE INFLATING.

- 2** Spray fittings with soap and water mixture.



- 3** Observe bubbles.

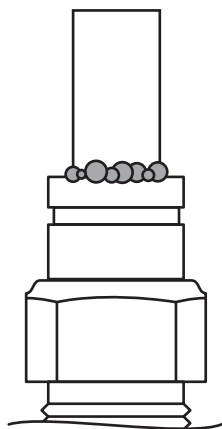

**SMALL SOAP BUBBLES
THAT DO NOT EXPAND**

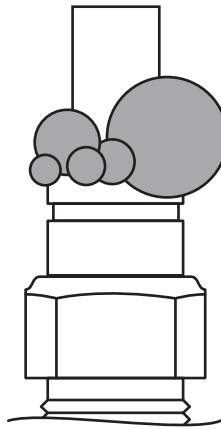

**SOAP BUBBLES
THAT EXPAND**



NO LEAKS?

Congratulations! Continue to step 14 to finish installation. Review the Operating Instructions.

LEAK?

Bummer. Continue to step 13 to fix the leak.

- 1 Press the air valve on end of inflation valve to release all air pressure.

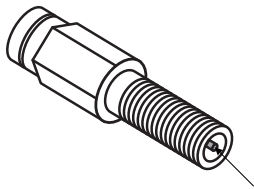

AIR VALVE



EXHAUST ALL AIR FROM THE SYSTEM PRIOR TO RELEASING AIR LINE TUBES FROM AIR FITTINGS.

LEAK AT AIR LINE TUBE AND AIR FITTING

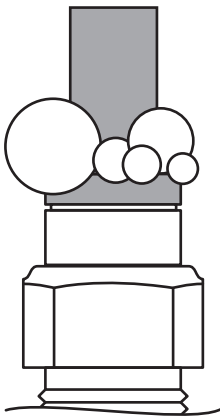

Release air line tube (see page 11). Review proper cuts and procedures in step 9. Repeat steps 10 and 12.

LEAK AT BASE OF AIR FITTING ON AIR SPRING

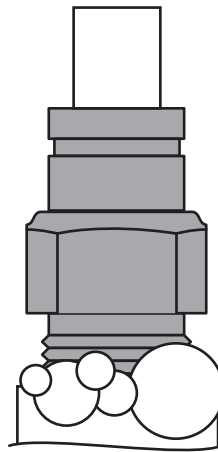

Tighten air fitting one turn or until leak stops.

LEAK OUT OF THE VALVE CORE ON INFLATION VALVE

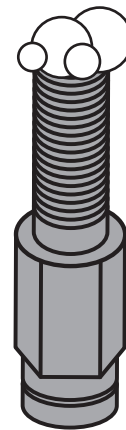

Tighten valve core with valve core wrench on inflation valve cap.

STILL HAVE A LEAK?

Refer to the Troubleshooting section of the Instruction Manual. If the leak persists, or if there is an issue with a leaking part, call 1-800-888-0650; Option 1; Option 1 for Tech Support.

SAFELY RETURN VEHICLE TO OPERATIVE STATE

If you removed any wheels during installation, install the wheels and torque the lug nuts to the manufacturer's specifications.

Safely remove any jack stands and wheel chocks used during installation.

Re-attach the negative battery cable.

DOUBLE-CHECK AIR SPRING CLEARANCE

Check the air springs once again for the proper 1/2" minimum clearance. Perform clearance check again when vehicle is under load.

VEHICLE GVWR

NEVER exceed the maximum load recommended by the vehicle manufacturer (GVWR). The GVWR can be found in your vehicle's owner's manual or on the data plate on the driver's side door. Consult your local dealership for additional GVWR specifications.

READ AND UNDERSTAND THE OPERATING INSTRUCTIONS

The Ride-Rite system can improve handling and comfort. Take the time to learn how to properly use and maintain your investment by reading the Operating Instructions.



USE YOUR HAND TO CHECK FOR THE PROPER CLEARANCE AROUND THE AIR SPRING. IF YOUR HAND DOES NOT FIT BETWEEN THE AIR SPRING AND OTHER COMPONENTS, IT WILL RUB!

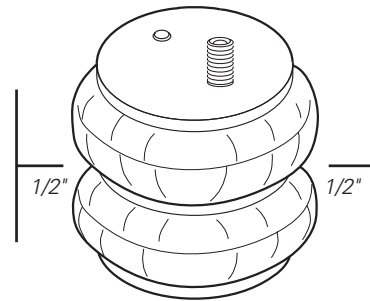

! IMPORTANT

A MINIMUM OF 5 PSI MUST BE MAINTAINED IN THE AIR SPRINGS AT ALL TIMES

Too much air pressure in the air springs will result in a firmer ride, while too little air pressure will allow the air springs to bottom out over rough conditions, and will not provide the improvement in handling that is possible.



MINIMUM PRESSURE



MAXIMUM PRESSURE (LOADED)



AIRIDE

firestoneairide.com

BEFORE YOU DRIVE, CONFIRM THE FOLLOWING:

- Do you have a minimum of 5PSI in your air springs?
- Are your air springs standing 5 1/2" - 6 1/2" tall?
- Are your air springs properly aligned, left-to-right and front-to-back?
- Are your nuts and bolts tight?
- Put your paperwork in your glove compartment for future reference.
- You've been bagged...and now your suspension is Airide™ equipped! Show it off with the supplied decal!

5 1/2" - 6 1/2"

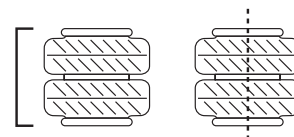

NEED INSTALLATION HELP?

Email us at rrtech@fsip.com. Please include photos, kit number, and the year, make, and model of the vehicle to help us better diagnose and understand any problems you may be experiencing.

CONNECT WITH US



FirestoneIP



Firestone Ride-Rite