

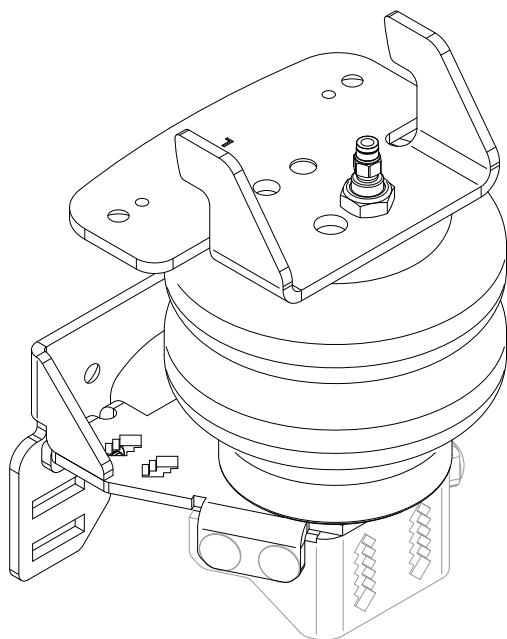

**AIRIDE**

firestoneairide.com

# INSTALLATION INSTRUCTIONS



**SECTION 1 - AIR SPRING**

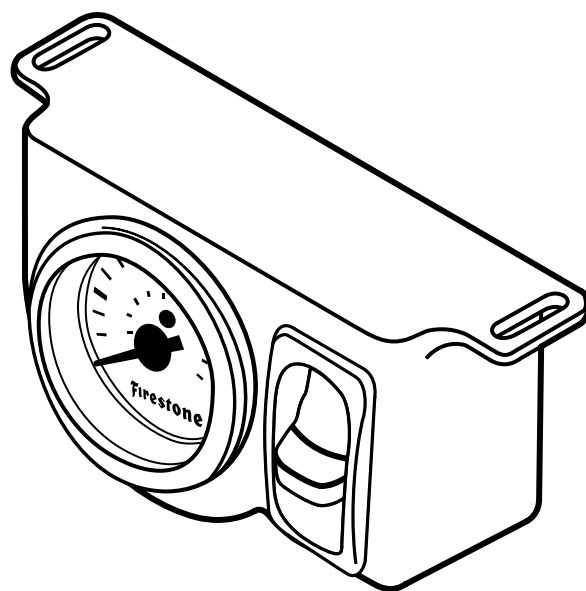

**SECTION 2 - AIR ACCESSORY**

# Firestone

## AIRIDE

[firestoneairide.com](http://firestoneairide.com)

# INSTALLATION INSTRUCTIONS

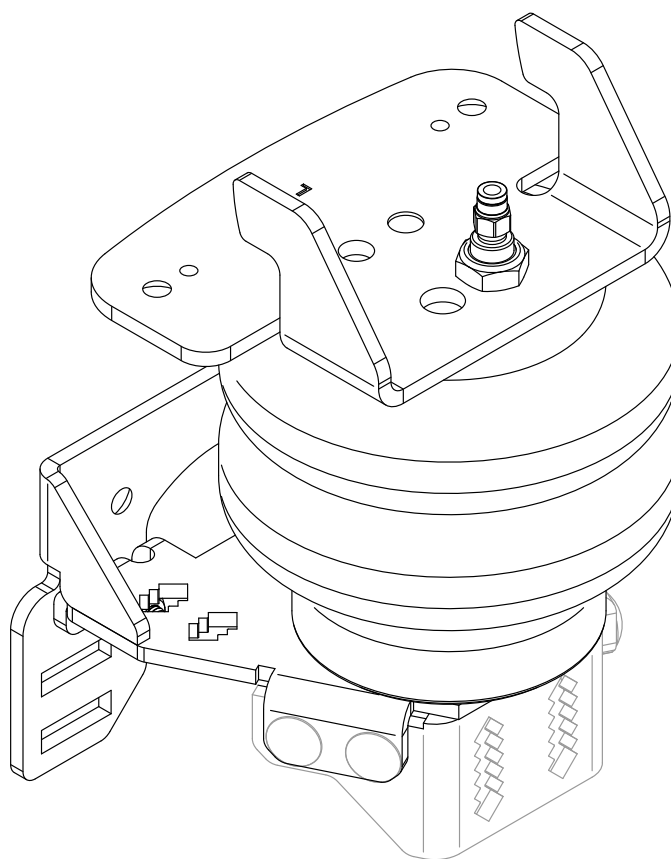

# ! IMPORTANT

*PLEASE DON'T HURT YOURSELF, YOUR KIT OR YOUR VEHICLE. TAKE A MINUTE TO READ THIS IMPORTANT INFORMATION.*

**DO NOT INSTALL IF THE TRUCK HAS BEEN LIFTED AND THE STOCK JOUNCE BUMPER SPACERS ARE NOT ON THE VEHICLE.** *This kit is to be used on a **pickup truck only**, and **DOES NOT INCREASE YOUR VEHICLE'S MAXIMUM LOAD.***

## **SAFE INSTALLATION**

Please take all safety precautions during installation. A hydraulic jack can fail, and if that happens, you can be seriously hurt, or worse, if you are relying on it to hold up the vehicle. If you use a hydraulic jack, secure jack stands in the appropriate locations and chock any tires still touching the ground.

Wear safety glasses or goggles. Your eyes may be lower than some parts and pieces, and you don't want to lose an eye.

Remove the possibility of any electrical issues by disconnecting the negative battery cable.

## **KIT CLEARANCE**

There must be a minimum of 1/2" clearance around all installed components when the air springs are inflated and under a load. The air springs must flex and expand during operation, so the clearance keeps the kit from rubbing against parts of the vehicle.

## **VEHICLE GVWR**

NEVER exceed the maximum load recommended by the vehicle manufacturer (GVWR). The GVWR can be found in your vehicle's owner's manual or on the data plate on the driver's side door. Consult your local dealership for additional GVWR specifications.

## **INFLATING THE AIR SPRINGS**

When inflating air springs, add air pressure in small quantities, checking air pressure frequently. The air springs have much less air volume than a tire, so they inflate much more quickly.

## **PRESSURE TO LOAD**

The air springs will support approximately 50 lbs. of load for each PSI of inflation pressure (per pair). For example, 50 PSI of inflation pressure will support a load of 2500 lbs. per pair of air springs.

## **APPROPRIATE AIR PRESSURE**

For best ride, use only enough air pressure in the air springs to level the vehicle when viewed from the side (front to rear). This will vary, depending on the load, location of the load, condition of the existing suspension, and personal preference.

## **OPTIONAL T-FITTING**

This kit includes inflation valves and air line tube for each air spring, allowing you to compensate for unbalanced loads. If you prefer a single inflation valve system to provide equal pressure to both air springs, your dealer can supply the optional "T" fitting (Part # 3025 or WRI-760-3461 retail pack).



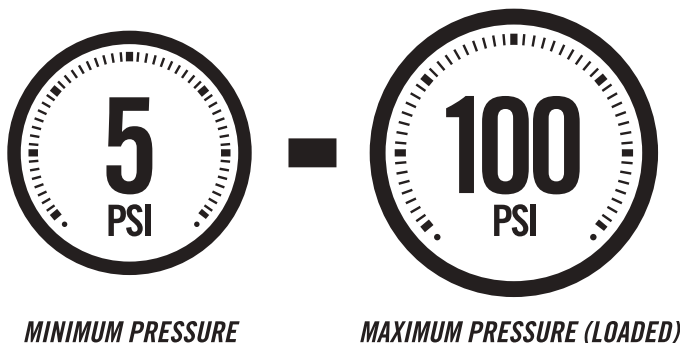



**ONCE INSTALLED SUCCESSFULLY, FOLLOW THESE PRESSURE REQUIREMENTS FOR THE AIR SPRINGS:**

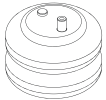
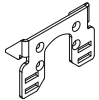
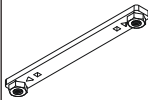
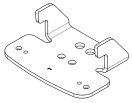
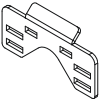

# PARTS

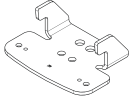
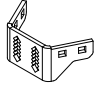

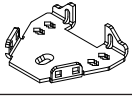
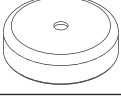
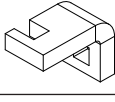
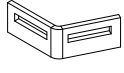



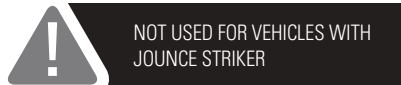





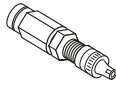



Compare the parts below to your kit. Assure you have all pieces, and organize them for an easier installation.

## MAIN KIT CONTENTS

PT # 6397	 x2 AIR SPRING	PT # 5939	 x2 LOWER FRAME BRACKET	PT # 5940	 x2 THREAD PLATE
PT # 5872	 x1 UPPER LEFT BRACKET	PT # 5942	 x2 LEAF SPRING BRACKET	PT # 1004	 x1 HEAT SHIELD
PT # 5873	 x1 UPPER RIGHT BRACKET	PT # 5957	 x2 SUPPORT BRACKET 	PT # 9415	 x1 AIR LINE TUBE (22 FEET)
PT # 5958	 x2 LOWER BRACKET	PT # 5336	 x2 AIR SPRING SPACER	PT # 5946	 x8 UNIVERSAL AXLE BRACKET
PT # 5959	 x2 SHORT SUPPORT BRACKET 	PT # 0045	 x2 PROTECTOR		

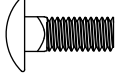

## A21-760-2625 HARDWARE PACK

PT # 3067	 x26 3/8" - 16 FLANGE LOCK NUT	PT # 3514	 x6 3/8" - 16 x 1" FLAT HEAD CAP SCREW	PT # 3032	 x2 INFLATION VALVE AND VALVE CAP ASSEMBLY
PT # 3033	 x4 5/16" FLAT WASHER	PT # 3430	 x2 3/8" - 16 x 2" FLAT HEAD CAP SCREW	PT # 3055	 x2 AIR FITTING
PT # 0899	 x2 THERMAL SLEEVE	PT # 3481	 x2 3/8" - 16 x 3" CARRIAGE BOLT	PT # 3502	 x8 3/8" - 16 x 6" CARRIAGE BOLT
PT # 3020	 x4 3/8" - 16 X 8" CARRIAGE BOLT	PT # 3332	 x2 5/8" - 18 NYLON JAM NUT	PT # 9036	 x10 RED NYLON TIE
PT # 9488	 x2 LARGE NYLON TIE	PT # 9483	 x1 NO-DRILL INFLATION VALVE BRACKET	PT # 3072	 x8 3/8" - 16 x 1" CARRIAGE BOLT
PT # 3515	 x4 3/8" - 16 x 2.5" FLAT HEAD CAP SCREW				

# **! NOTICE**

**This kit includes components that allow multiple build configurations.**

**Not every part will be used for each configuration.**

# CONTENTS AND OVERVIEW

JOUNCE STRIKER CONFIGURATION SHOWN - CHECK YOUR VEHICLE FIRST!



PAGE **6** REMOVE EXISTING JOUNCE BUMPER & INSTALL THREAD PLATE

PAGE **7** INSTALL UPPER BRACKET

PAGE **9** CREATE LOWER BRACKET ASSEMBLY

PAGE **11** DRY FIT AIR SPRING

PAGE **14** DRY FIT AIR SPRING

PAGE **12** MAKE ALIGNMENT MARKS

PAGE **15** MAKE ALIGNMENT MARKS

PAGE **13** DRY FIT LOWER BRACKET ASSEMBLY

PAGE **16** DRY FIT LOWER BRACKET ASSEMBLY

PAGE **17** MEASURE BETWEEN BRACKETS & INSTALL AIR SPRING

PAGE **18** INSTALL AIR SPRING INTO UPPER BRACKET

PAGE **19** INSTALL LOWER BRACKET ASSEMBLY

PAGE **20** INSTALL AXLE STRAP BRACKET

PAGE **21** INSTALL HEAT SHIELD ON RIGHT SIDE

PAGE **22** INSTALL INFLATION VALVES & CUT THE AIR LINE TUBE INTO TWO EQUAL LENGTHS

PAGE **23** ROUTE AND SECURE AIR LINE TUBES & INSTALLING AIR LINE TUBE

PAGE **24** CHECKING THE AIR SYSTEM

PAGE **21** FIXING AN AIR LEAK

PAGE **21** FINISHING THE INSTALLATION



YOUR VEHICLE WILL REQUIRE ADDITIONAL PARTS FROM THIS KIT IF IT DOES NOT HAVE A JOUNCE STRIKER

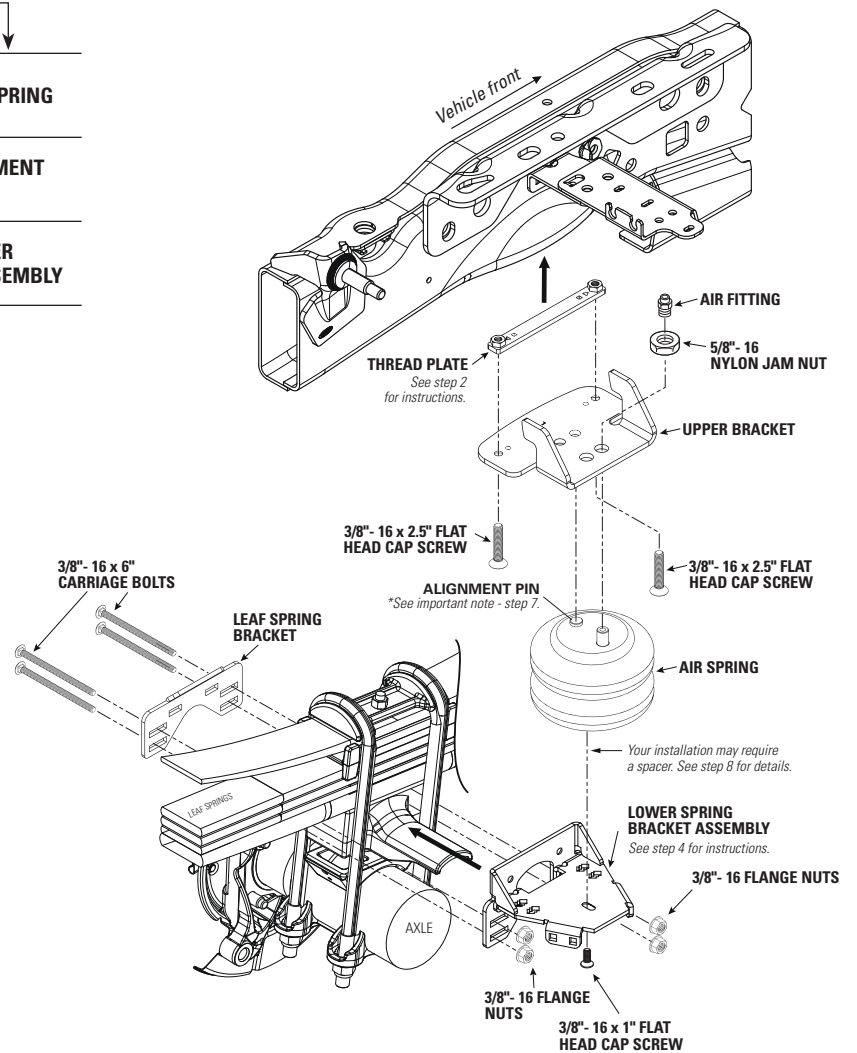

## ! IMPORTANT NOTE

If necessary for installation clearance, slightly bend the brackets on the left (driver) side which supports the brake line and axle vent tube. After removing the plastic ABS mount from its hole in the axle bracket, use an adjustable wrench or similar tool to bend the bracket approximately 1/8" (3mm). Replace the ABS mount when proper clearance is obtained.

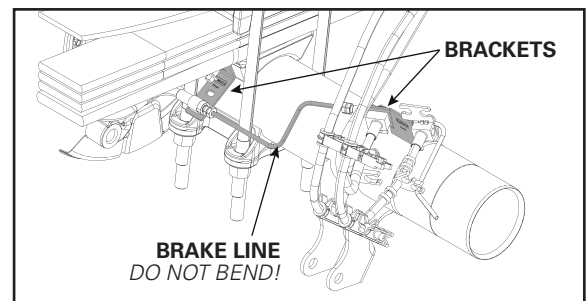

# 1

## REMOVE EXISTING JOUNCE BUMPER



START ON THE LEFT SIDE OF THE VEHICLE WHILE FACING FORWARD.

Remove the existing jounce bumper and fastener clips from the vehicle frame.

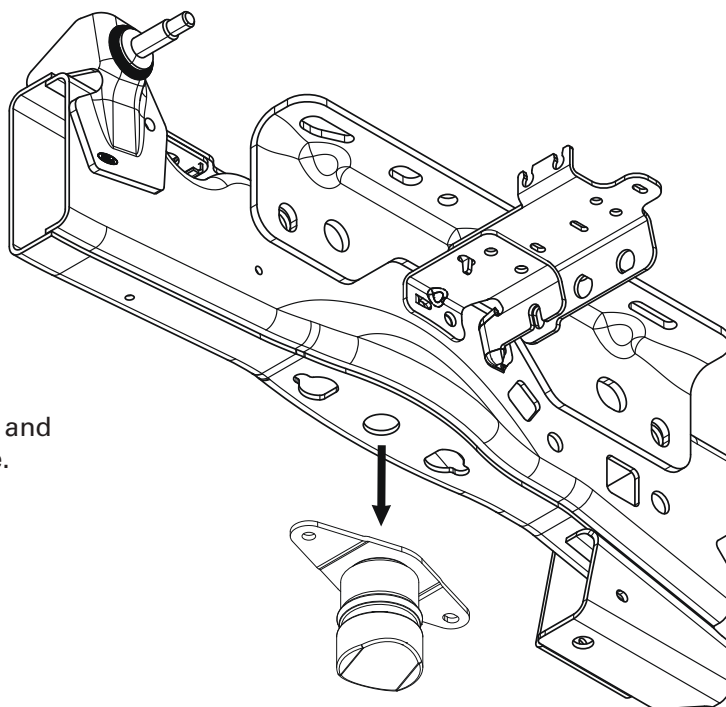

# 2

## INSTALL THREAD PLATE

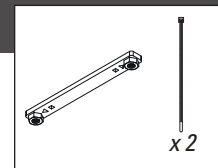

Attach nylon ties to the thread plate, as shown. These act as installation guides for the thread plate and upper bracket. They will be removed in a later step.

Insert the thread plate into the vehicle frame, as shown. Use nylon ties as handles to position thread plate.

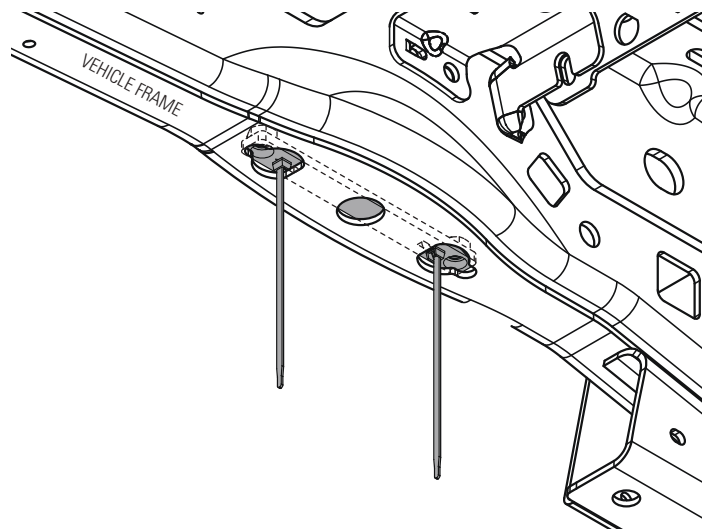
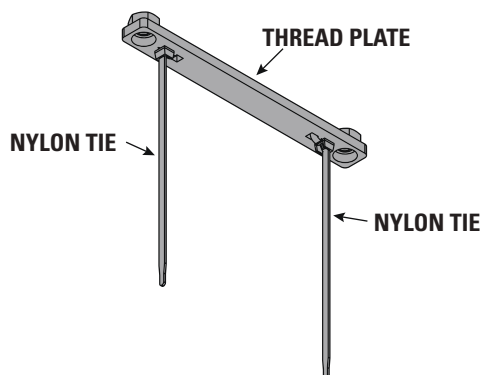

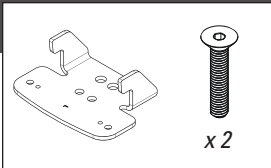

- 1** Guide the two nylon ties into the inner holes in the upper bracket.
- 2** While holding the thread plate in place with the nylon ties, **hand-thread** the fasteners in place.
- 3** Once the fasteners have begun engaging the threads, use snips or a knife to trim the nylon ties flush with the frame.
- 4** Fully-tighten the fasteners.

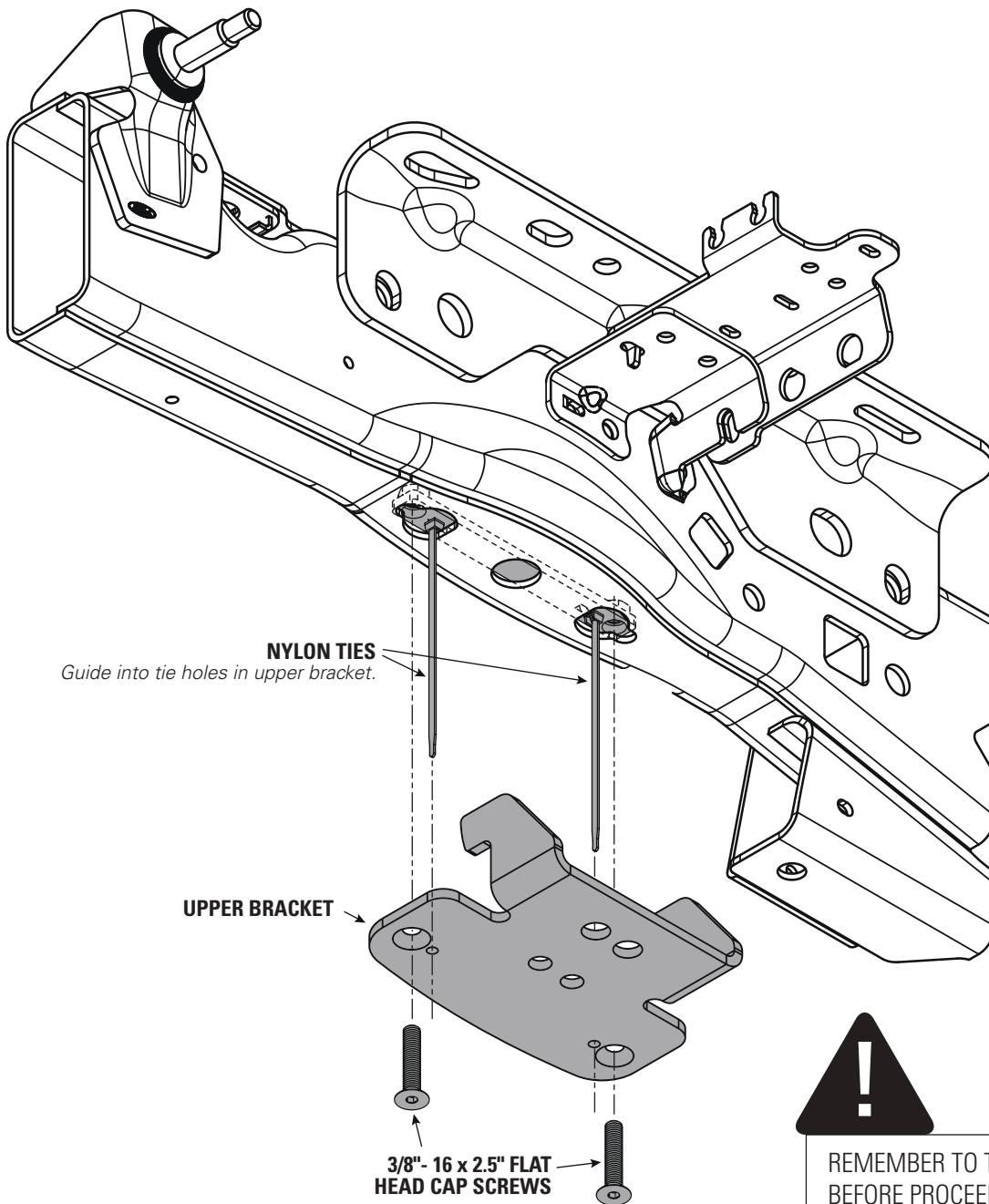



# **! WARNING**

**The lower bracket must be supported by the factory jounce striker (if present) or by the installation of the appropriate support bracket.**

**Failure to support the lower bracket will cause mounting system failure and void all warranty.**

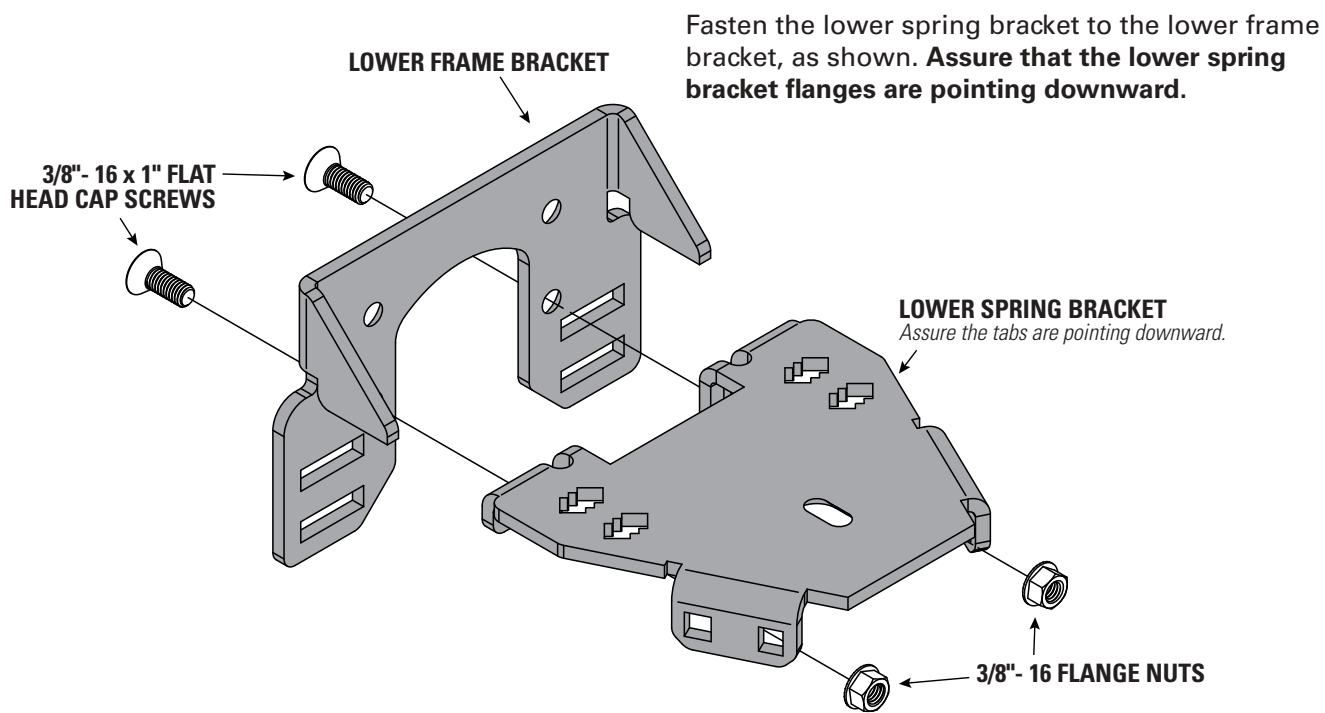
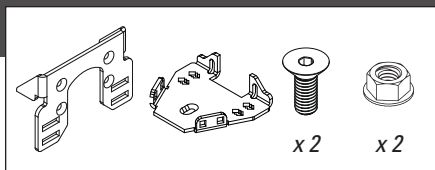

# **! NOTICE**

**If your truck has a jounce  
striker plate as shown  
below, continue to the  
next step.**

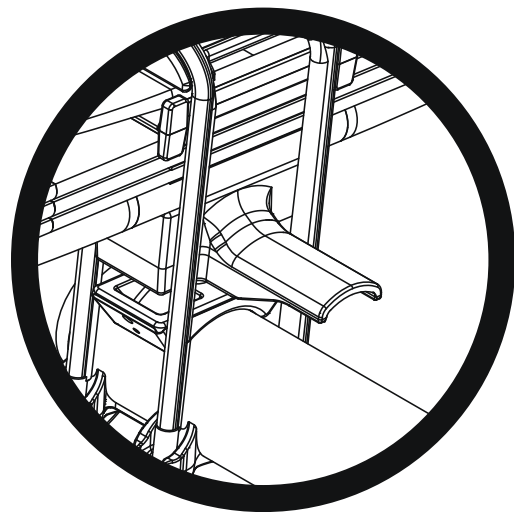

**If it does not, skip to step 5  
on page 14.**

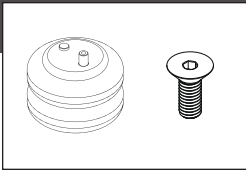

# Jounce striker plate version only



Fasten the air spring to the lower spring bracket.  
**DO NOT FULLY TIGHTEN AT THIS STAGE.**

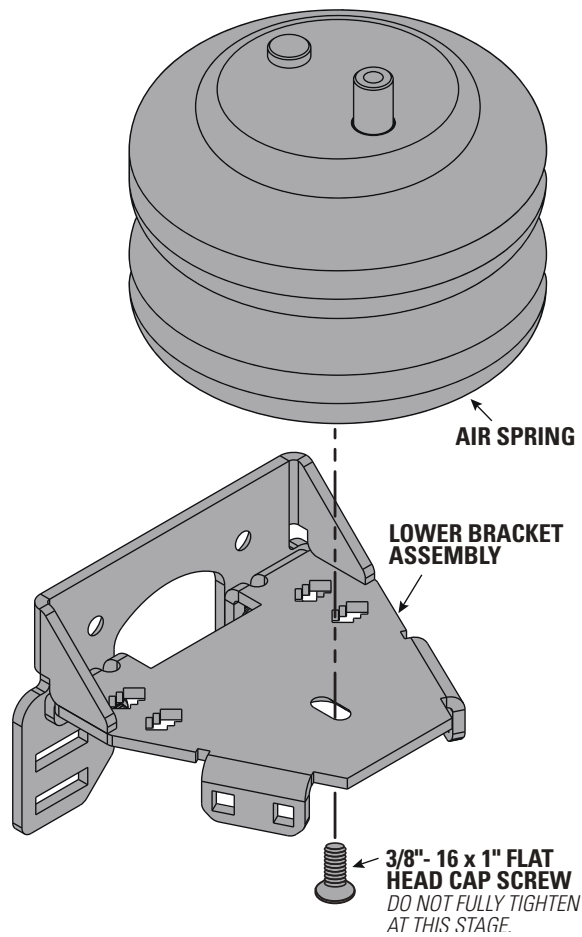

# Jounce striker plate version only

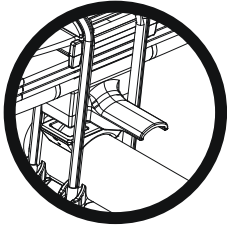

**1** Insert the alignment pin and combo stud into the front alignment holes, as shown.

**2** Position the lower bracket assembly tight to the u-bolts and assure the combo stud and alignment pin are fully seated.

**3** Make alignment marks, as shown.

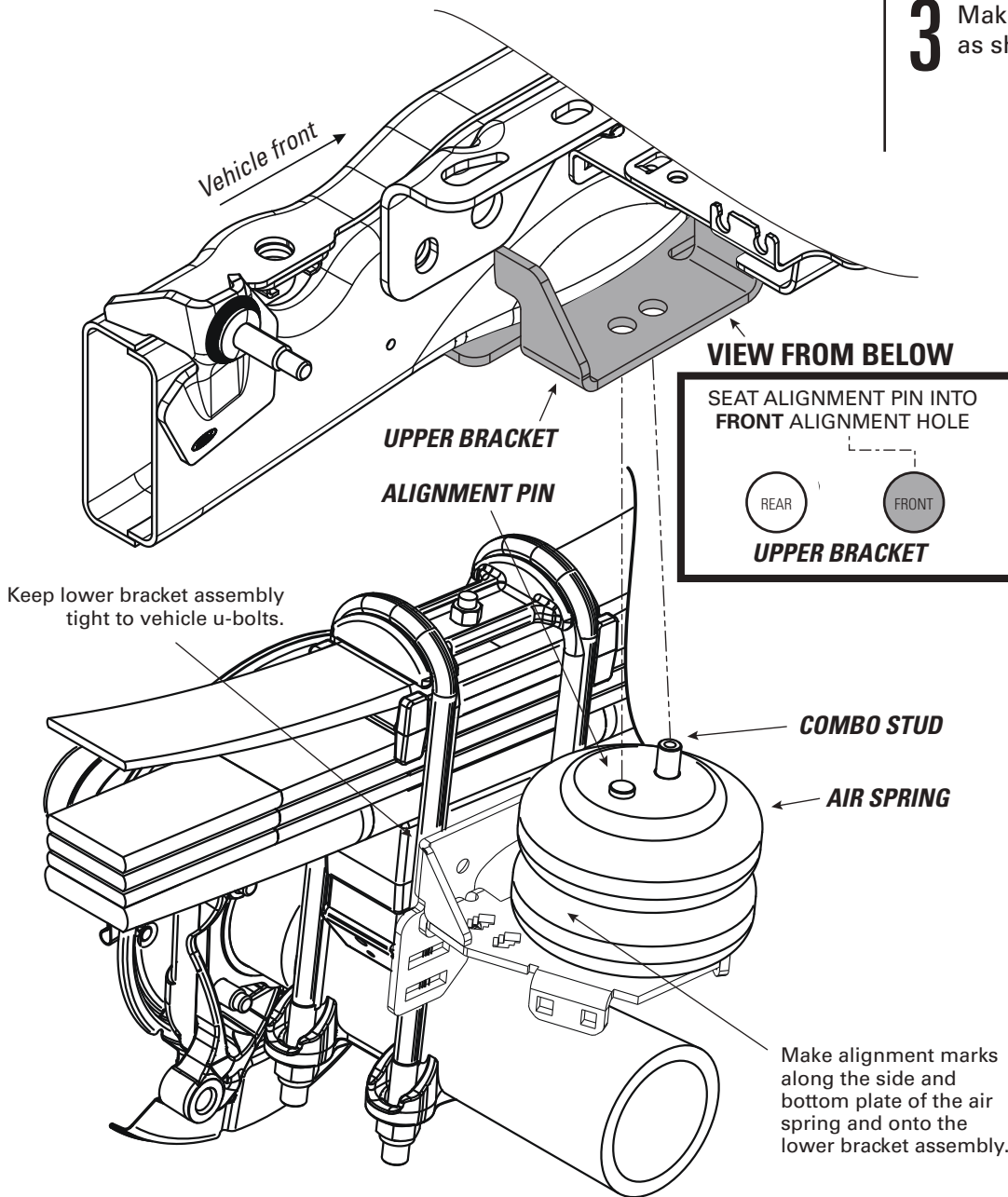

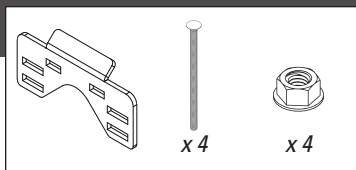

# Jounce striker plate version only

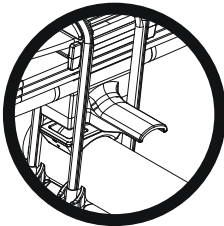
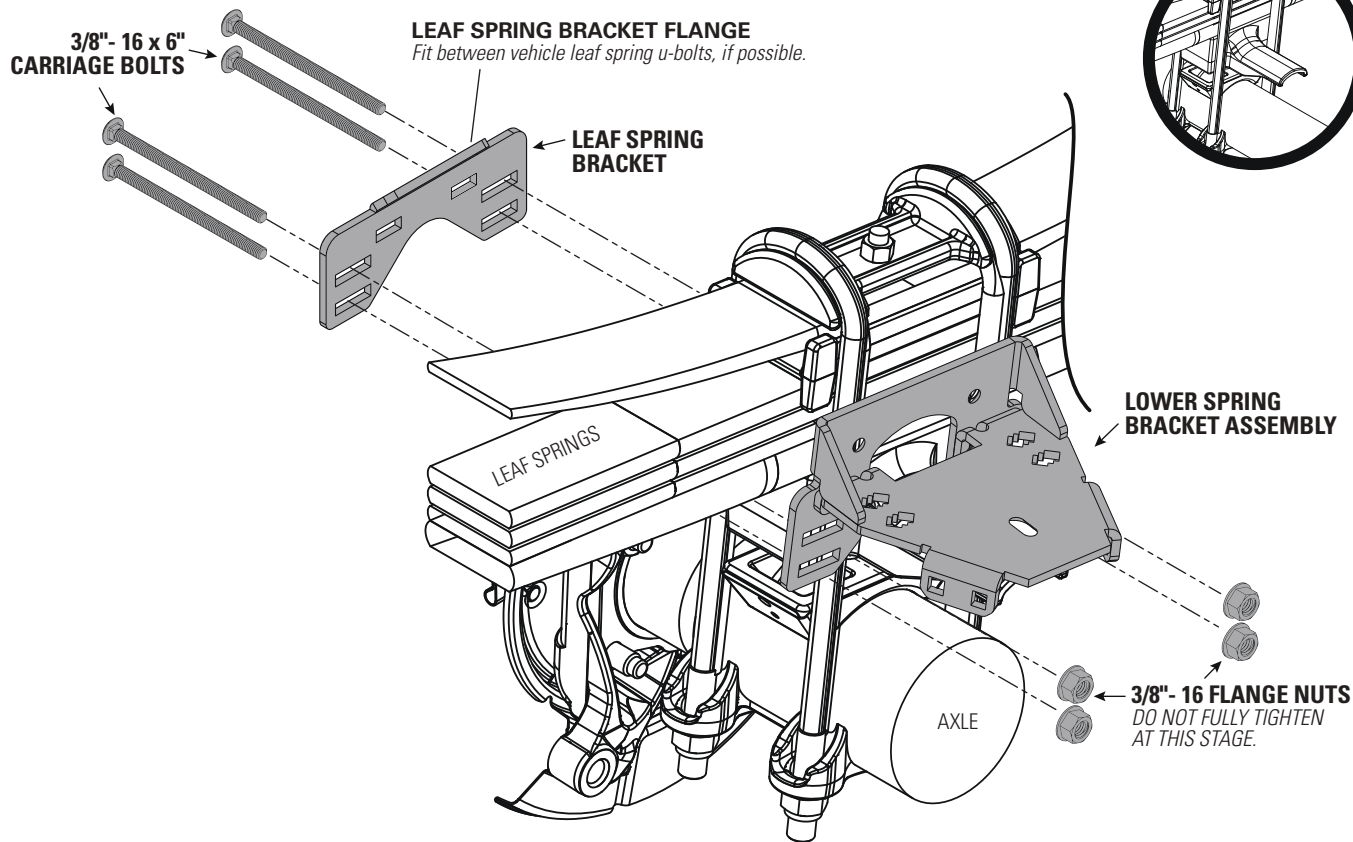

**1** Remove air spring and fastener from lower bracket assembly.

**2** Install the lower bracket assembly so that it is tight against the vehicle jounce tongue and leaf spring stack.

**3** Do not fully tighten at this stage. You will remove the assembly after the next step.

## Continue to bracket measuring instructions step 8 on page 17.

# 5b

## DRY FIT AIR SPRING

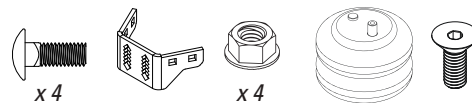

# Support bracket version only

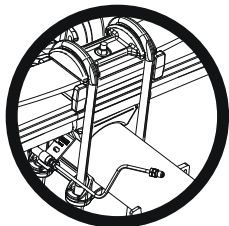

IF CARRIAGE BOLTS IN STEP 7B INTERFERE WITH LEAF SPRING, 5959 SHORT SUPPORT BRACKET MAY BE ATTACHED TO EITHER SIDE OF 5958 LOWER BRACKET INSTEAD OF 5957

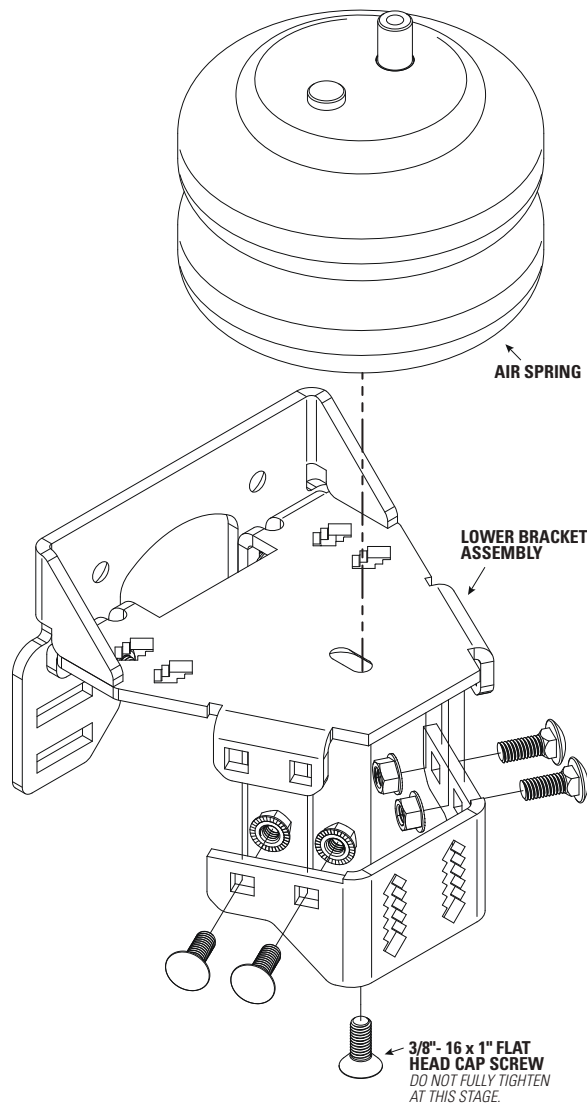
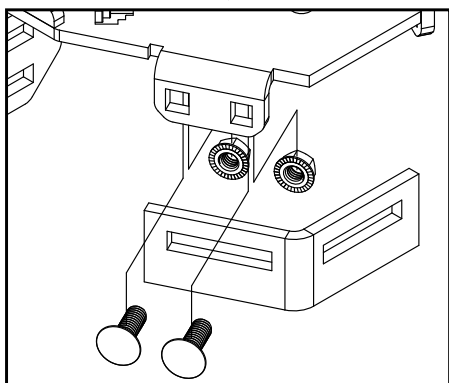

Fasten the air spring to the lower spring bracket.  
**DO NOT FULLY TIGHTEN AT THIS STAGE.**

# Support bracket version only

**1** Insert the alignment pin and combo stud into the front alignment holes, as shown.

**2** Position the lower bracket assembly tight to the u-bolts and assure the combo stud and alignment pin are fully seated.

**3** Make alignment marks, as shown.

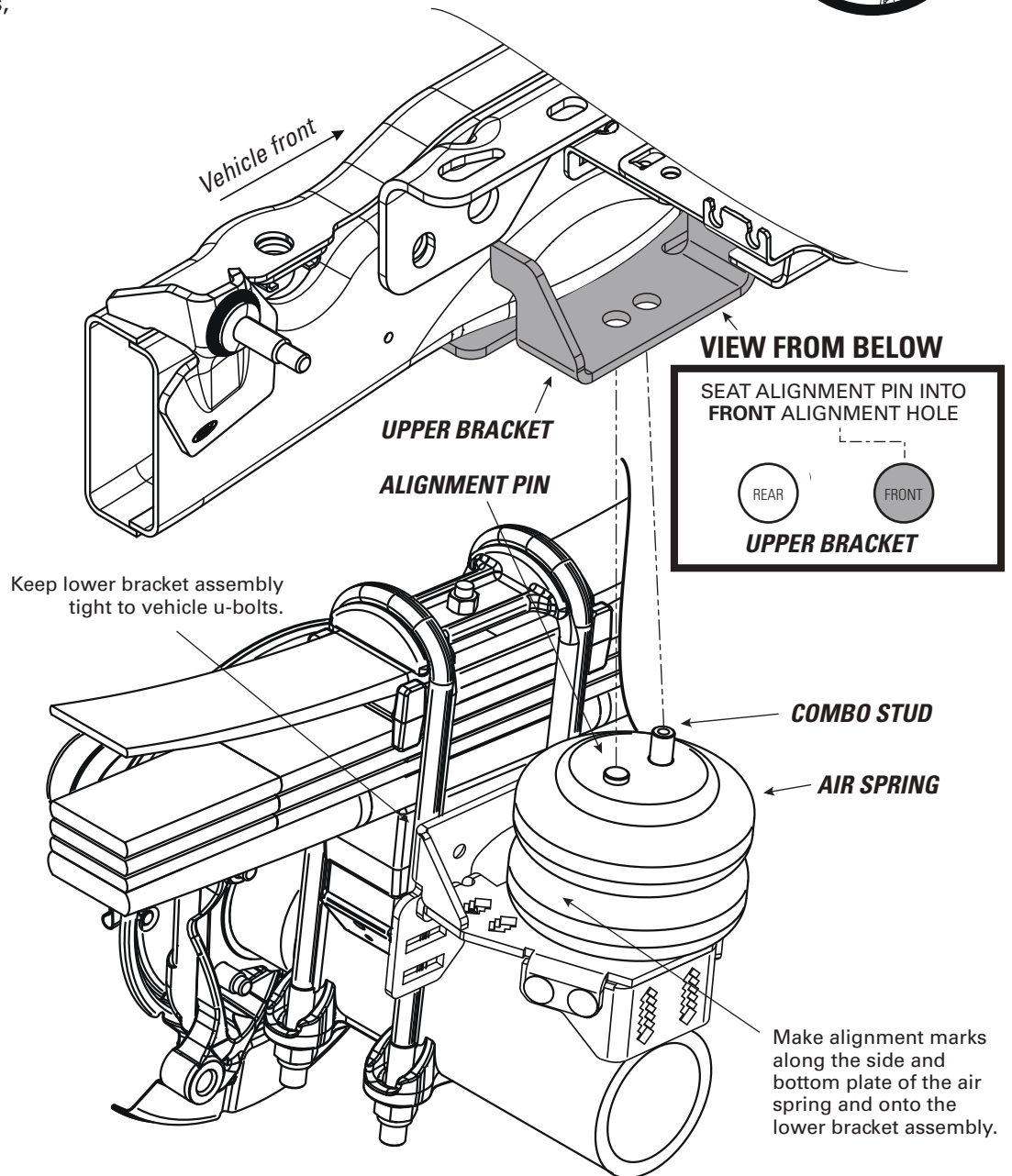
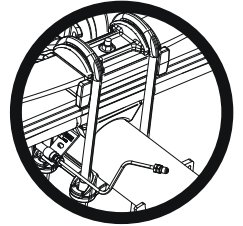



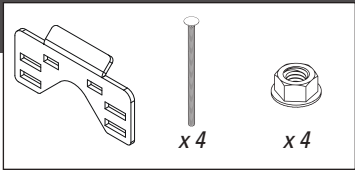

# Support bracket version only

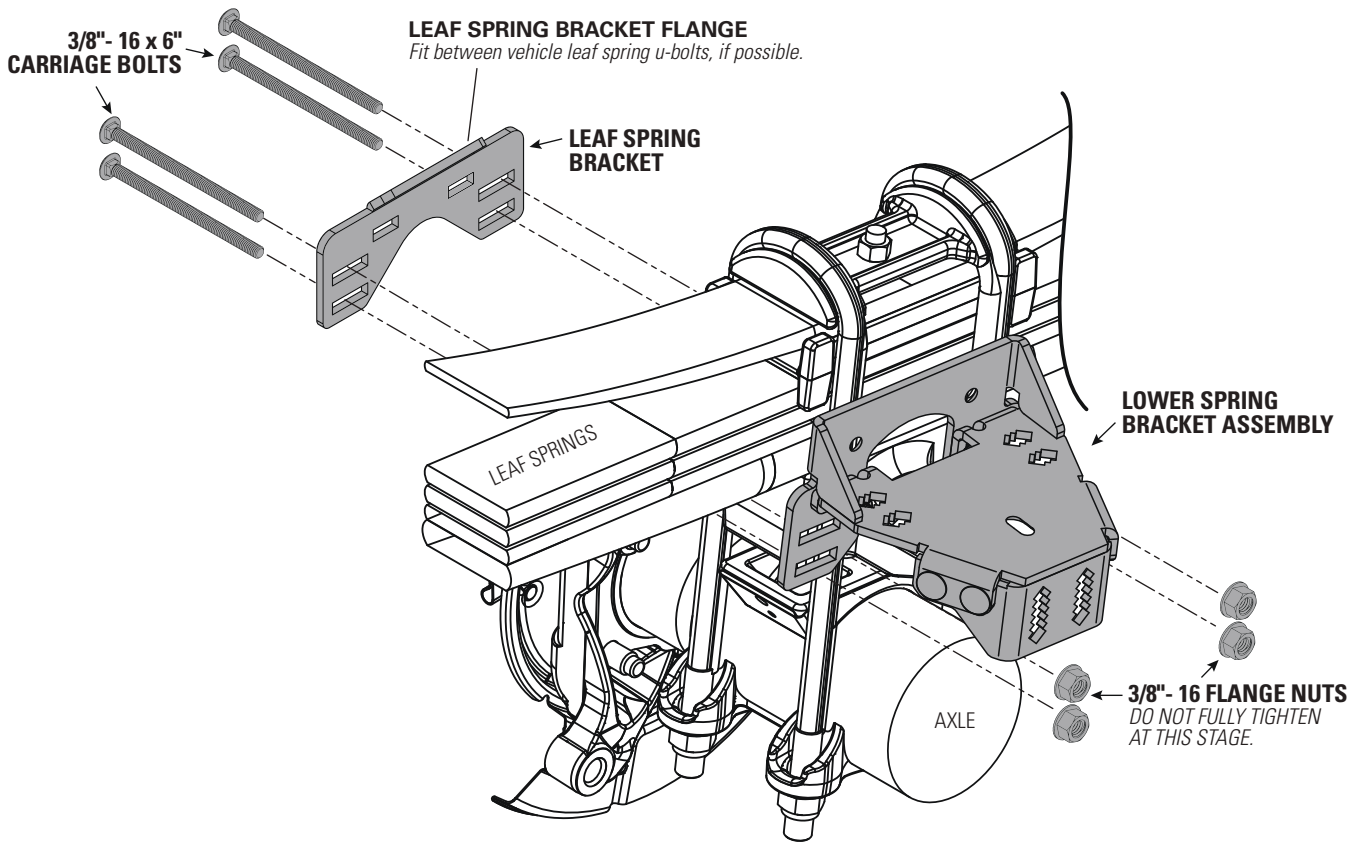
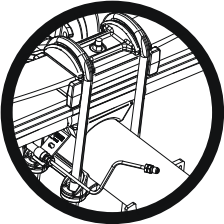

**1** Remove air spring and fastener from lower bracket assembly.

**2** Install the lower bracket assembly so that it is tight against the vehicle jounce tongue and leaf spring stack.

**3** Do not fully tighten at this stage. You will remove the assembly after the next step.

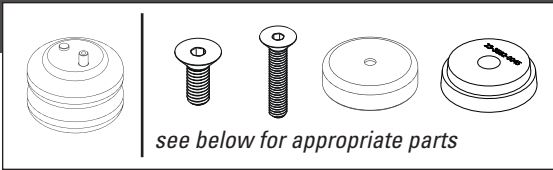

With vehicle unloaded on level ground and supporting its own weight, measure the distance between the bottom of the upper bracket and the top of the lower bracket. Use your measurement to follow the appropriate steps below.

**STANDARD INSTALLATION**

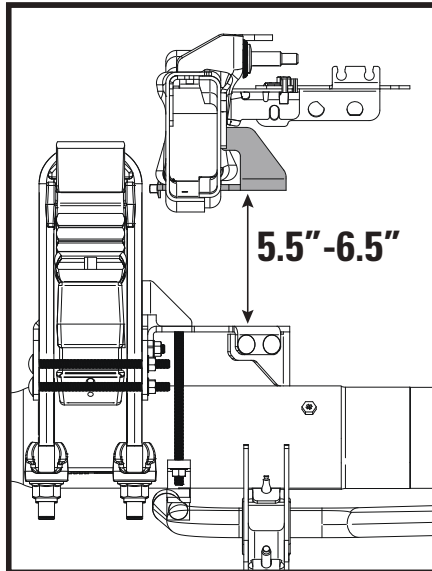

**5.5\"/>**

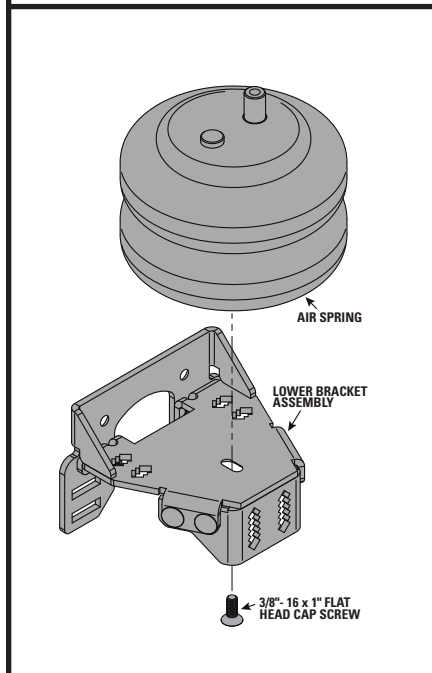

**INSTALLATION WITH SPACER**

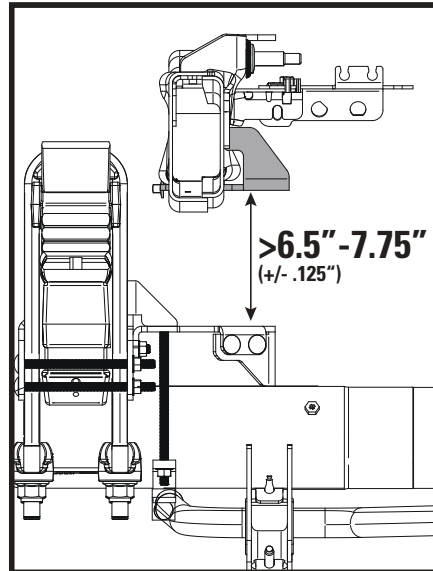

**> 6.5\"/>**

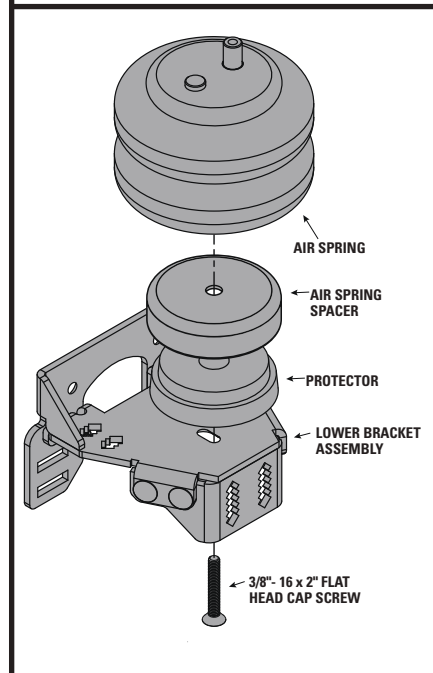

**LARGER SPACER REQUIRED**

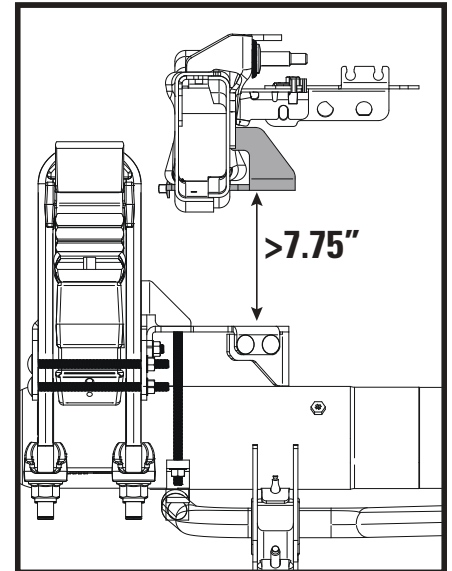

**> 7.75\"/>**

See Firestone catalog to order correct spacer to achieve the proper 5.5\"/>

**!** THE SUPPORT BRACKET VERSION IS SHOWN. MEASUREMENT PROCEDURE IS SAME FOR EITHER CONFIGURATION.

**!** YOUR ALIGNMENT MARKS MUST LINE UP BEFORE FULLY TIGHTENING THE CAP SCREW.

# 9

## INSTALL AIR SPRING TO UPPER BRACKET



INSTALLING THE RIGHT SIDE? REMEMBER TO INSTALL THE HEAT SHIELD IN STEP 11 FIRST!

**1** Install the air spring combo stud into the **front** alignment hole in the upper bracket. Fully-seat the air spring alignment pin into the **front** alignment hole.

**2** Fully tighten the top of the air spring to the upper bracket.

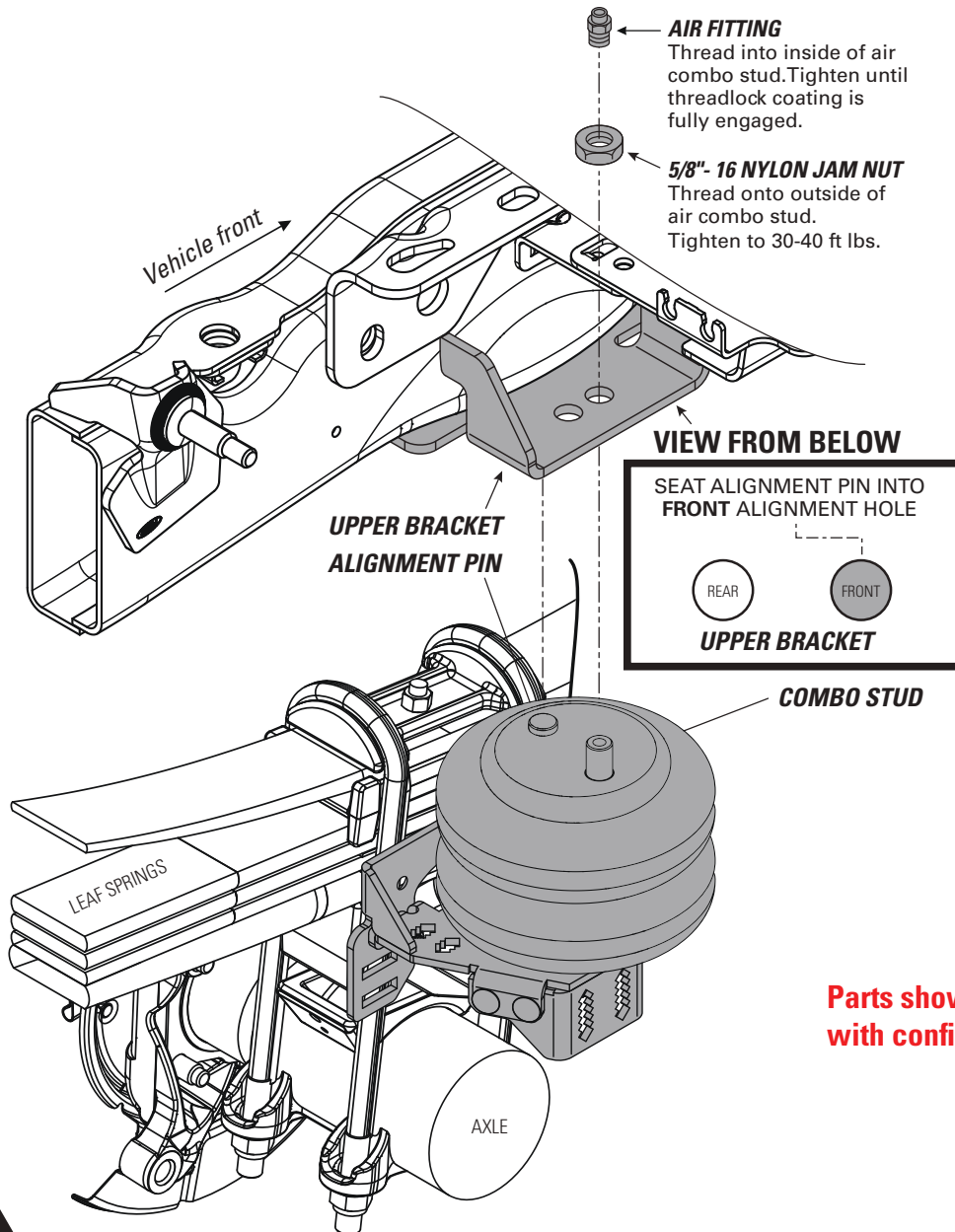

Parts shown will vary with configuration



ALIGNMENT PIN ON AIR SPRINGS MUST BE INSTALLED TO FULLY SEAT INTO THE FRONT ALIGNMENT HOLE IN THE UPPER BRACKET. FAILURE TO DO SO WILL CAUSE IT TO BE PUSHED INTO THE BEAD PLATE, CREATING AN AIR LEAK, AND RESULTING IN AN AIR SPRING FAILURE THAT IS **NOT WARRANTABLE**. **THE ALIGNMENT PIN CANNOT HOLD 2,500 LBS! IT IS USED FOR ALIGNMENT ONLY!**

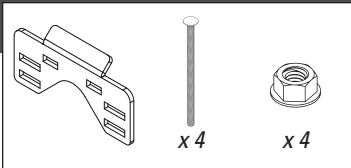

**1** Place the lower bracket assembly on top of the jounce bumper tongue and against the inboard side of the vehicle leaf spring stack.

**2** Place the leaf spring bracket on the outboard side of the leaf spring stack. If possible, fit the leaf spring bracket flange between the vehicle leaf spring u-bolts.

**3** Install the fasteners as shown.

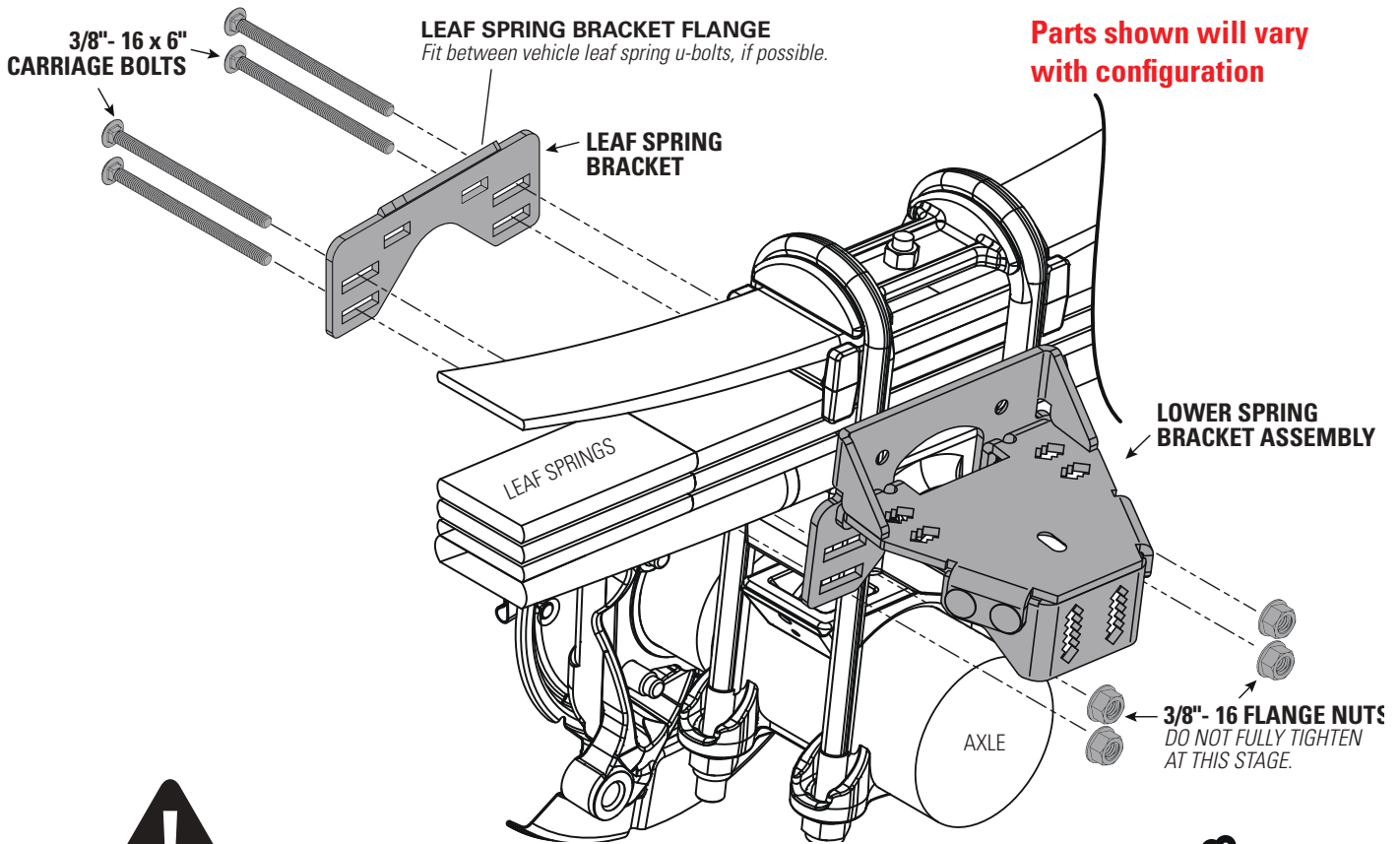

USE YOUR HAND TO CHECK FOR THE PROPER CLEARANCE AROUND THE AIR SPRING. IF YOUR HAND DOES NOT FIT BETWEEN THE AIR SPRING AND OTHER COMPONENTS, IT WILL RUB!



**AWESOME!** You're done with the left side. The right side is the same, with the addition of the heat shield. See step 8, then complete the steps for the right side installation.

# 11

## INSTALL AXLE STRAP BRACKET

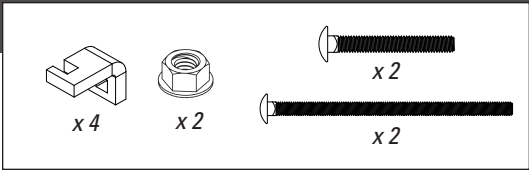

- 1 Link two pairs of universal axle brackets together to form an "M" as shown below.
- 2 Insert large carriage bolt into the hole of the lower bracket closest to the leaf spring and axle tube with the bolt as upright as possible.
- 3 Loosely attach one pair of universal axle brackets across the bottom with a small carriage bolt with a flange lock nut.
- 4 Connect both pairs of universal axle brackets across the bottom with a small carriage bolt and a flange lock nut.
- 5 **Completely tighten all fasteners to 23 ft-lb.**

**!** THE SUPPORT BRACKET VERSION IS SHOWN. THE INSTALLATION IS THE SAME FOR EITHER CONFIGURATION.

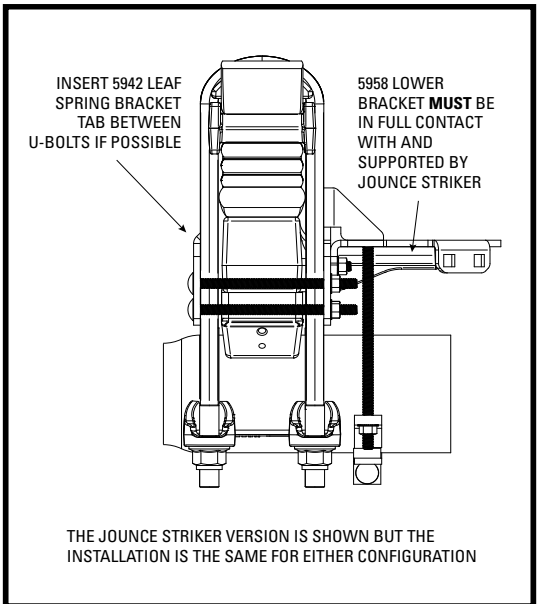
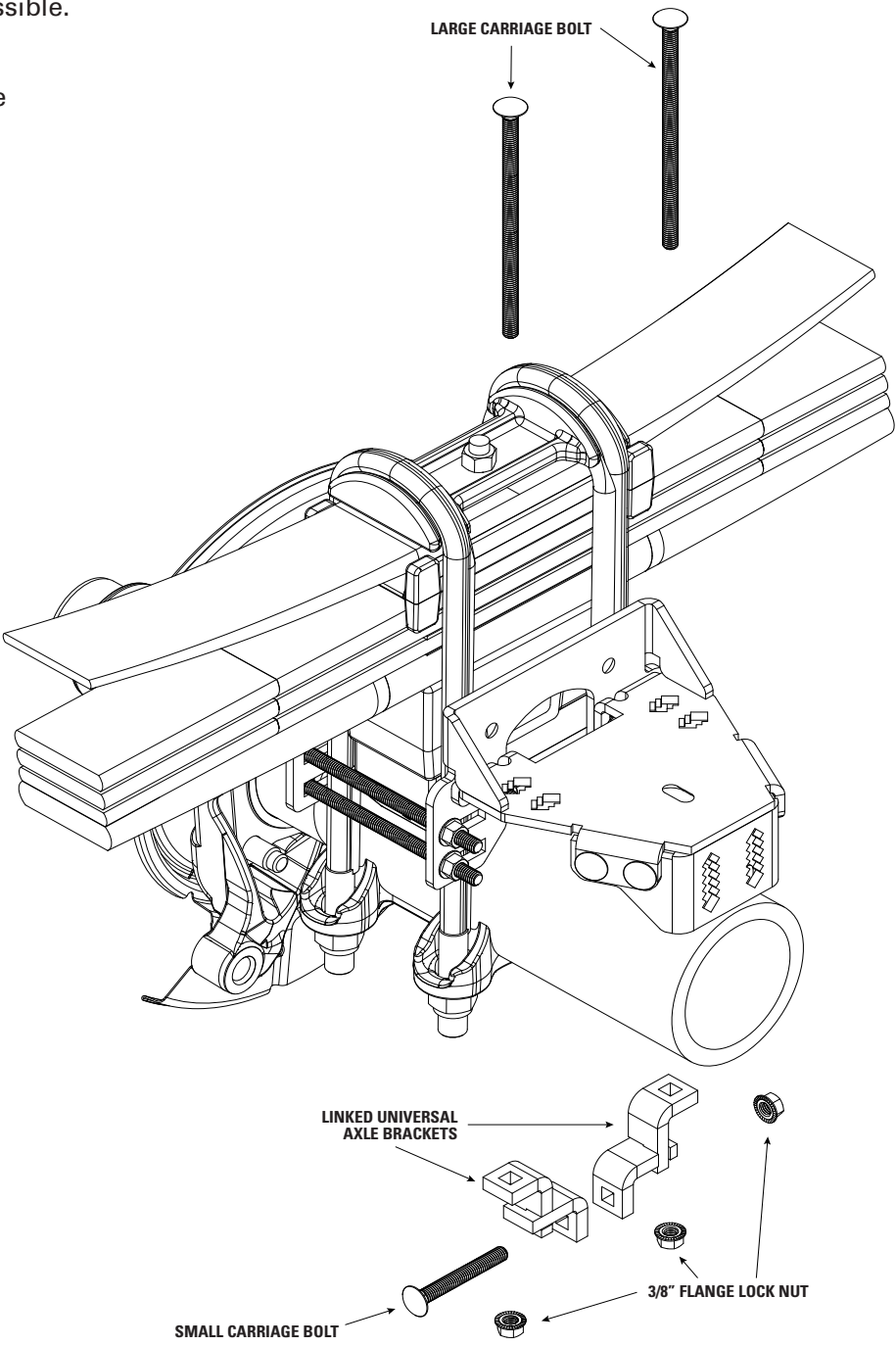

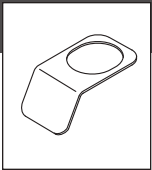

RIGHT SIDE INSTALLATION MUST INCLUDE HEAT SHIELD!

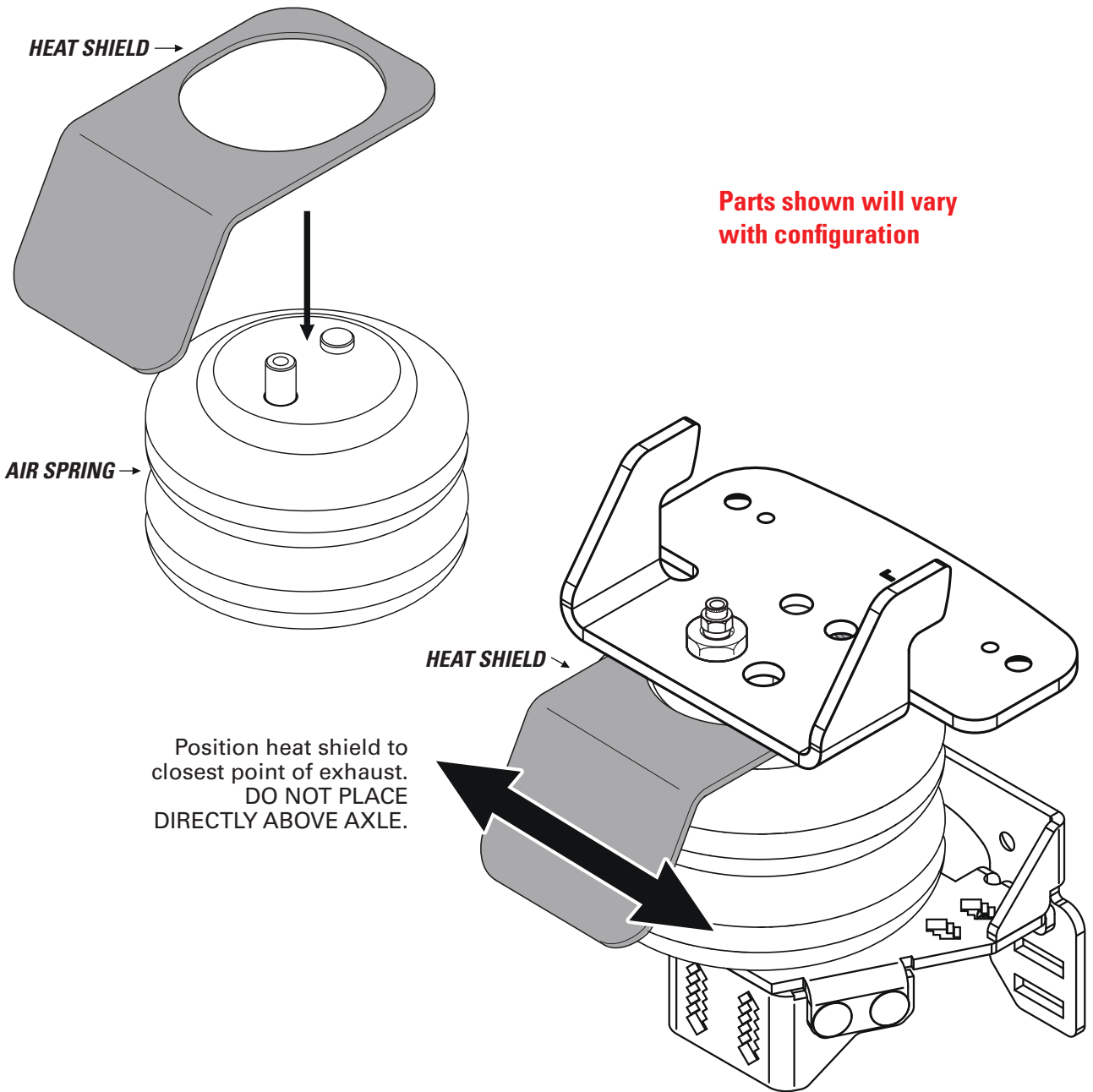

# 13

## INSTALL INFLATION VALVES

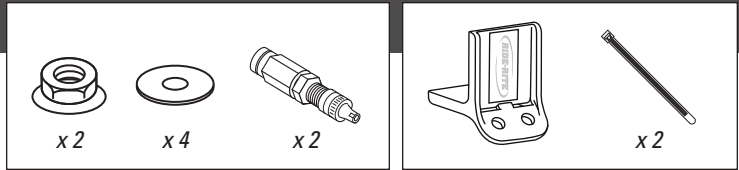

IF USING THE OPTIONAL NO-DRILL INFLATION VALVE BRACKET, CHOOSE OPTION 1. IF DRILLING, CHOOSE OPTION 2. **INFLATION VALVES MUST BE ACCESSIBLE BY AN AIR CHUCK.**

**1** Secure the air inflation valve bracket to a protected, secure location.

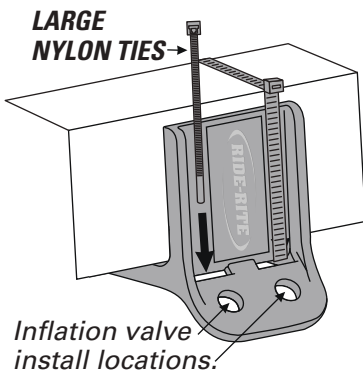

**2** Select a protected location to install the inflation valves, such as the bumper or the body of the vehicle.

Drill two 5/16" holes for inflation valve install locations.

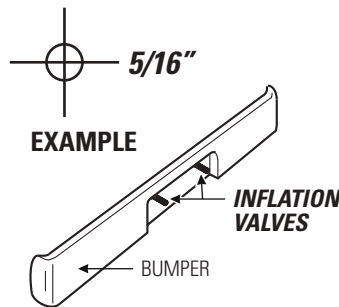

### INFLATION VALVE ASSEMBLY

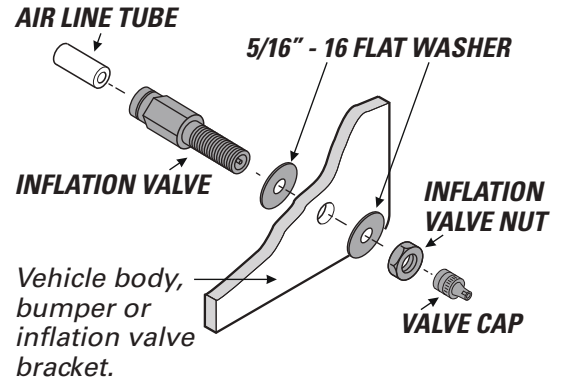

# 14

## CUT THE AIR LINE TUBE INTO TWO EQUAL LENGTHS

**1** Match air line tube ends.

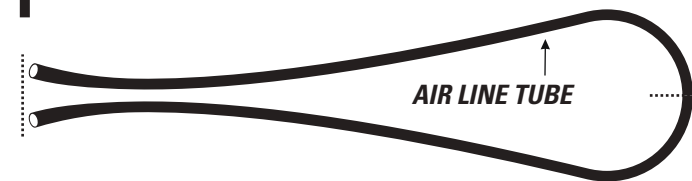

**2** Find center of air line tube, make a square cut with tube cutter or sharp utility knife.

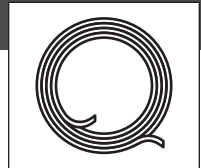

# DO

Make sure the cut is as square as possible. Use a tube cutter or sharp utility knife.

# DON'T

Fold or kink the air line tube. Cut the air line tube at an angle. Use pliers, scissors, snips, Saws, or side cutters.

### PROPER AND IMPROPER CUTS IN THE AIR LINE TUBE

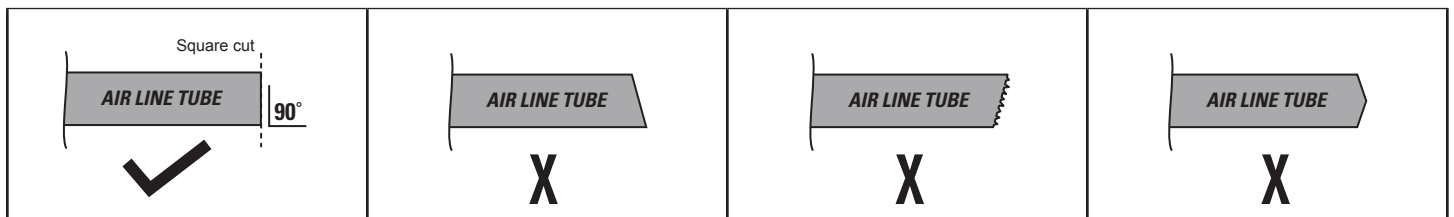

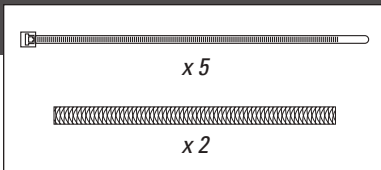

Air line tube routes will vary, depending on your truck, and requires you to choose the best path from the air springs to the inflation valves. Use the instructions below to help you choose.

**DO**

Select routes protected from heat, Debris, and sharp edges. Use thermal shields near heat sources. Use nylon ties to secure the air line tube.

**DON'T**

Bend or sharply curve air line tubes. Leave air line tube exposed to sharp edges. Use unnecessary lengths of air line tube. Route air line tube near moving parts. Let air line tube hang unsecured from vehicle. Scar air line tube while routing.

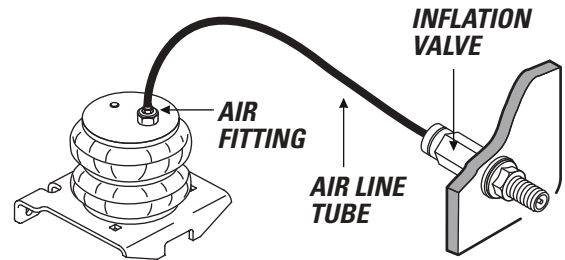
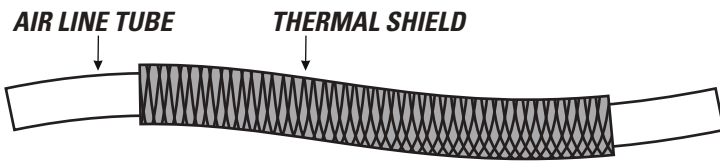

USE SUPPLIED THERMAL SHIELDS WHEN AIR LINE TUBE RUNS **WITHIN 6 INCHES** OF HEAT SOURCES.



**1** Insert end of air line tube into air fitting.

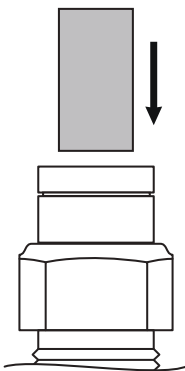

**2** Push air line tube into air fitting as far as possible.

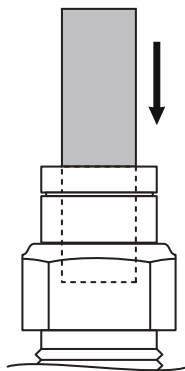

**3** Gently pull on the air line tube to check for a secure fit.

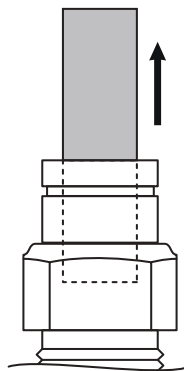

**AIR LINE REMOVAL**

To remove, push down collar and gently pull air line tube away.

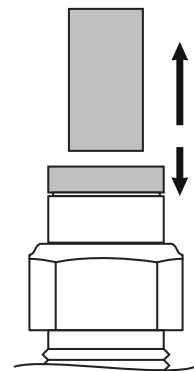

**Removal Tip:** Use a 1/4", 5/16", or 6mm open-ended wrench to push the collar down.



# 17

## CHECKING THE AIR SYSTEM

**1** Place an air chuck onto the inflation valve and fill the system to **70 PSI**.

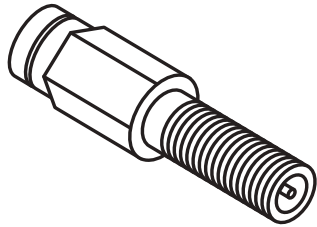

AIR SPRINGS INFLATE QUICKLY. CHECK AIR PRESSURE WHILE INFLATING.

**2** Spray fittings with soap and water mixture or glass cleaner.



**3** Observe bubbles.

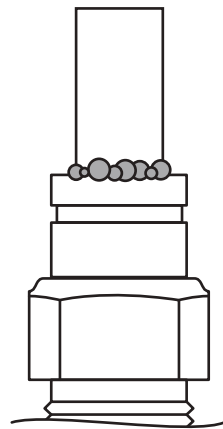

**SMALL SOAP BUBBLES THAT DO NOT EXPAND**

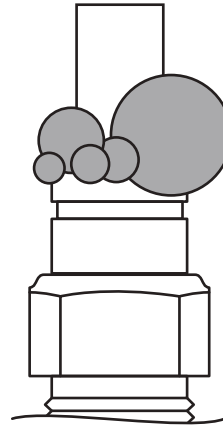

**SOAP BUBBLES THAT EXPAND**



# NO LEAKS?

Congratulations! Continue to step 18 to finish installation. Review the Operating Instructions.

# LEAK?

Bummer. Continue to step 17 to fix the leak.

- 1** Press the air valve on end of inflation valve to release all air pressure.

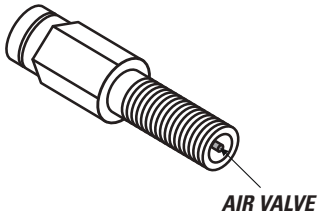

EXHAUST ALL AIR FROM THE SYSTEM PRIOR TO RELEASING AIR LINE TUBES FROM AIR FITTINGS.

#### LEAK AT AIR LINE TUBE AND AIR FITTING

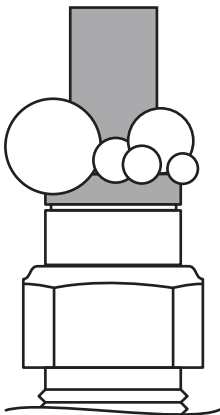

Release air line tube (see page 15). Review proper cuts and procedures in step 13. Repeat steps 15 and 16.

#### LEAK AT BASE OF AIR FITTING ON AIR SPRING

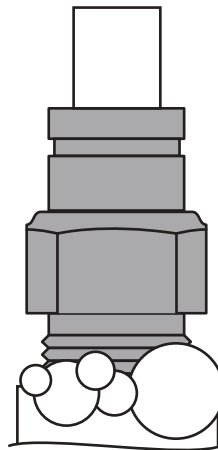

Tighten air fitting one turn or until leak stops.

#### LEAK OUT OF THE VALVE CORE ON INFLATION VALVE

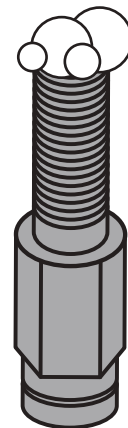

Tighten valve core with valve core wrench on inflation valve cap.

# STILL HAVE A LEAK?

Refer to the Troubleshooting section of the Instruction Manual.

**SAFELY RETURN VEHICLE TO OPERATIVE STATE**

If you removed any wheels during installation, install the wheels and torque the lug nuts to the manufacturer's specifications.

Safely remove any jack stands and wheel chocks used during installation.

Re-attach the negative battery cable.

**DOUBLE-CHECK AIR SPRING CLEARANCE**

Check the air springs once again for the proper 1/2" minimum clearance. Perform clearance check again when vehicle is under load.

**VEHICLE GVWR**

NEVER exceed the maximum load recommended by the vehicle manufacturer (GVWR). The GVWR can be found in your vehicle's owner's manual or on the data plate on the driver's side door. Consult your local dealership for additional GVWR specifications.

**READ AND UNDERSTAND THE OPERATING INSTRUCTIONS**

The Ride-Rite system can improve handling and comfort. Take the time to learn how to properly use and maintain your investment by reading the Operating Instructions.



USE YOUR HAND TO CHECK FOR THE PROPER CLEARANCE AROUND THE AIR SPRING. IF YOUR HAND DOES NOT FIT BETWEEN THE AIR SPRING AND OTHER COMPONENTS, IT WILL RUB!

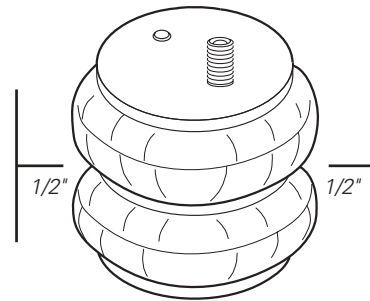

# ! IMPORTANT

**A MINIMUM OF 5 PSI MUST BE MAINTAINED IN THE AIR SPRINGS AT ALL TIMES**

Too much air pressure in the air springs will result in a firmer ride, while too little air pressure will allow the air springs to bottom out over rough conditions, and will not provide the improvement in handling that is possible.



MINIMUM PRESSURE



MAXIMUM PRESSURE (LOADED)

# Firestone

## AIRIDE

[firestoneairide.com](http://firestoneairide.com)

### BEFORE YOU DRIVE, CONFIRM THE FOLLOWING:

- Do you have a minimum of 5PSI in your air springs?
- Are your air springs standing 5 1/2" - 6 1/2" tall?
- Are your air springs properly aligned, left-to-right and front-to-back?
- Are your nuts and bolts tight?
- Put your paper work in your glove compartment for future reference.
- You've been bagged...and now your suspension is Airide™ equipped!

5 1/2" - 6 1/2"

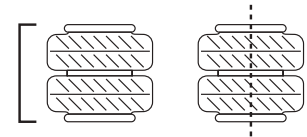

## NEED INSTALLATION HELP?

Email us at [rrtech@fsip.com](mailto:rrtech@fsip.com). Please include photos, kit number, and the year, make, and model of the vehicle to help us better diagnose and understand any problems you may be experiencing.

CONNECT WITH US



@FirestoneAiride



FirestoneAiride



Firestone Airide



**AIRIDE**

[firestoneairide.com](http://firestoneairide.com)

# INSTALLATION INSTRUCTIONS

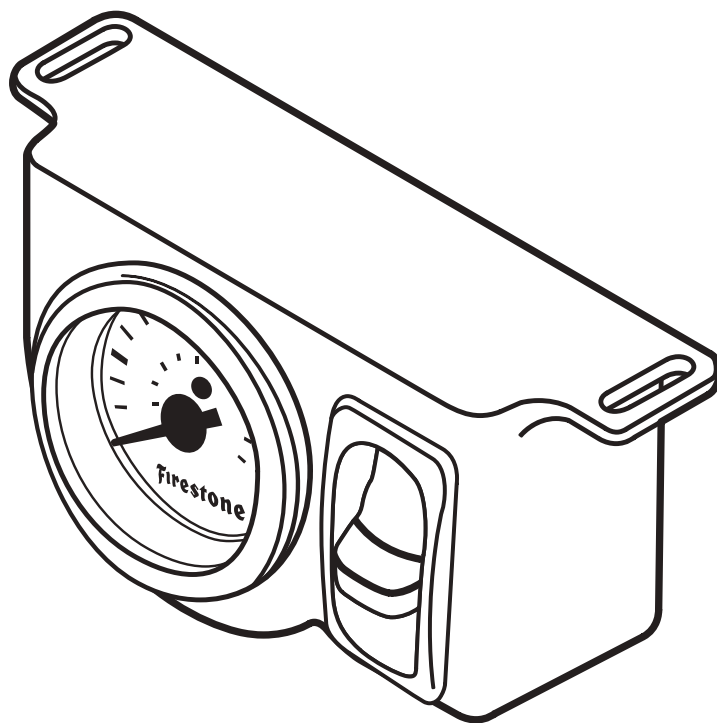

# ! IMPORTANT

*PLEASE DON'T HURT YOURSELF, YOUR KIT OR YOUR VEHICLE. TAKE A MINUTE TO READ THIS IMPORTANT INFORMATION.*

## **SAFE INSTALLATION**

Please take all safety precautions during installation. A hydraulic jack can fail, and if that happens, you can be seriously hurt, or worse, if you are relying on it to hold up the vehicle. If you use a hydraulic jack, secure jack stands in the appropriate locations and chock any tires still touching the ground.

Wear safety glasses or goggles. Your eyes may be lower than some parts and pieces, and you don't want to lose an eye.

Remove the possibility of any electrical issues by disconnecting the negative battery cable.

## **VEHICLE GVWR**

NEVER exceed the maximum load recommended by the vehicle manufacturer (GVWR). The GVWR can be found in your vehicle's owner's manual or on the data plate on the driver's side door. Consult your local dealership for additional GVWR specifications.

## **INFLATING THE AIR SPRINGS**

When inflating air springs, add air pressure in small quantities, checking air pressure frequently. The air springs have much less air volume than a tire, so they inflate much more quickly.

## **PRESSURE TO LOAD**

Be sure to review the load limits noted in the Air Spring Kit Installation Instructions (sold separately).

## **APPROPRIATE AIR PRESSURE**

For best ride, use only enough air pressure in the air springs to level the vehicle when viewed from the side (front to rear). This will vary, depending on the load, location of the load, condition of the existing suspension, and personal preference.

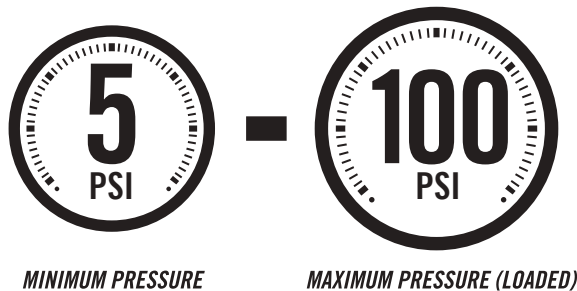

***ONCE INSTALLED SUCCESSFULLY, FOLLOW THE PRESSURE REQUIREMENTS FOR THE AIR SPRINGS:***



# PARTS

Compare the parts below to your kit. Ensure you have all pieces, and organize them for an easier installation.

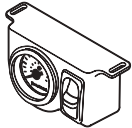
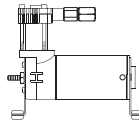
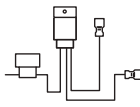





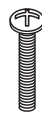

## MAIN KIT CONTENTS

PT # 7550	 x 1	SINGLE AIR CONTROL PANEL	PT # 9523	 x 1	AIR COMPRESSOR	PT # 9307	 x 1	RELAY HARNESS
PT # 9416	 x 1	AIR LINE TUBE (30 FEET)						

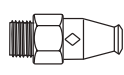
## A24-760-2635 COMPRESSOR MOUNTING KIT

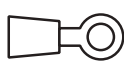
KIT # 2635	 x 1	COMPRESSOR MOUNTING KIT	The parts list for this kit is in the Mounting Kit Manual included at the end of this Manual.					
------------	---	-------------------------	---	--	--	--	--	--

## A21-760-2900 HARDWARE PACK

PT # 3087	 x 8	10-32 x 1" MACHINE SCREW	PT # 9078	 x 1	RED RING TERMINAL	PT # 3055	 x 1	1/8 NPT PUSH-TO-CONNECT STRAIGHT FITTING
PT # 3088	 x 8	10-32 LOCK NUT	PT # 9083	 x 2	WIRE CONNECTOR	PT # 9041	 x 1	LARGE RING TERMINAL
PT # 3086	 x 16	#10 FLAT WASHER	PT # 3025	 x 2	PUSH-TO-CONNECT T-FITTING	PT # 9036	 x 15	NYLON TIE
PT # 3421	 x 1	10-16 x 3/4" SELF-TAPPING SCREW						

# CONTENTS AND OVERVIEW

- PAGE 4 PLANNING THE INSTALL

---

- PAGE 5 PREPARE AIR COMPRESSOR & CONTROL PANEL

---

- PAGE 6 DRILL HOLES FOR AIR COMPRESSOR INSTALLATION

---

- PAGE 7 INSTALL THE AIR COMPRESSOR

---

- PAGE 8 AIR COMPRESSOR TO CONTROL PANEL AIR LINE TUBE

---

- PAGE 9 AIR SPRINGS TO CONTROL PANEL AIR LINE TUBE

---

- PAGE 10 INSTALL RELAY HARNESS

---

- PAGE 11 FINISH CONTROL PANEL WIRING & INSTALLATION

---

- PAGE 12 INSTALL THE AIR FILTER & CLEAN UP INSTALLATION

---

- PAGE 13 TEST THE SYSTEM

---

- PAGE 14 FIXING AN AIR LEAK

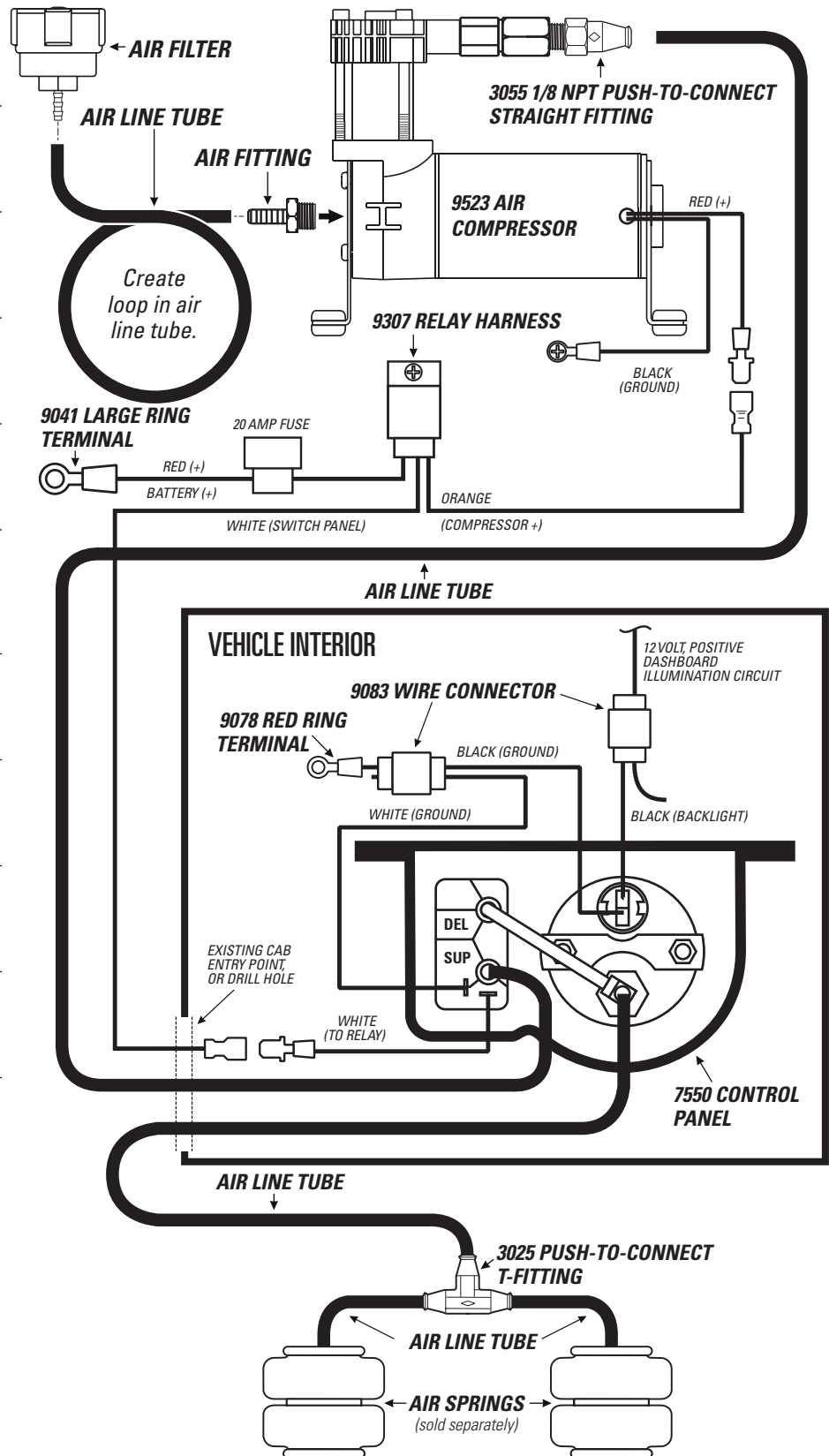



# PLANNING THE INSTALL

THESE PLANNING STEPS WILL HELP YOU SAVE TIME AND WILL MAKE THE INSTALLATION EASIER.

## **DETERMINE THE MOUNTING LOCATION FOR THE CONTROL PANEL**

- Mount inside the vehicle cab, in a place where you will not hit or kick it.
- Allow room for the air line tube to run without sharp curves or bends.
- Do not obstruct your view or ability to safely operate the vehicle.

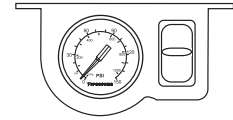

## **DETERMINE THE MOUNTING LOCATION FOR THE AIR COMPRESSOR**

- Use the provided Mounting Kit (Part # 2635) to mount the Compressor, considering the guidelines below, and follow the kit's instructions.
- Provide ample air flow.
- Protect from airborne debris and moisture.
- Optionally you can drill holes to mount the compressor to the frame, see Section 3

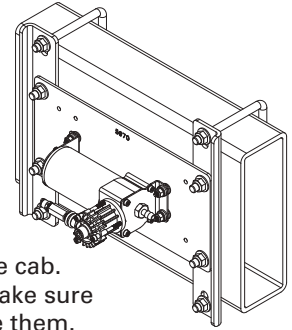

## **PLAN INSTALLATION ROUTES FOR WIRING AND AIR LINES INTO CAB**

- If possible, use existing factory grommet, such as where a wiring harness enters the cab.
- If not possible, drill a hole large enough for two air line tubes and a ground wire. Make sure the wiring and air line tubes are not exposed to sharp metal edges that can damage them.

## **SOAK AIR LINE TUBE ENDS IN HOT WATER BEFORE INSTALLING ONTO BARBED FITTINGS**

- The hot water makes the air line tube easier to work with and enables it to shrink onto the barbed fitting for a better seal.



## **TAPE ALL ELECTRICAL CONNECTIONS**

- Use electrical tape to appropriately secure and protect all electrical connections.

## **USING PUSH-TO-CONNECT FITTINGS FOR AIR LINES**

Your kit includes push-to-connect fittings to connect the air line tubes to hardware. Use the instructions below when using the air line.

- 1** Insert end of air line tube into air fitting.

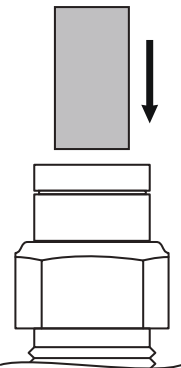

- 2** Push air line tube into air fitting as far as possible.

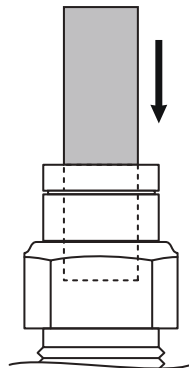

- 3** Gently pull on the air line tube to check for a secure fit.

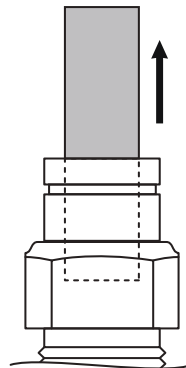

- 4** To remove, push down collar and gently pull air line tube away.

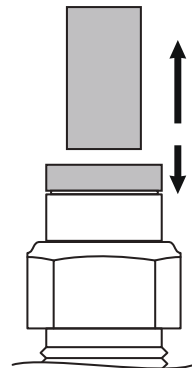

**Removal Tip:** Use a 1/4", 5/16", or 6mm open-ended wrench to push the collar down.

# 1

## PREPARE THE AIR COMPRESSOR

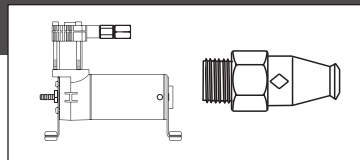

- 1 Install 1/8 NPT Push-to-Connect Straight Fitting on the Check Valve.

- 2 Install Barbed Air Fitting in Inlet Port of the Compressor from Air Compressor Kit.

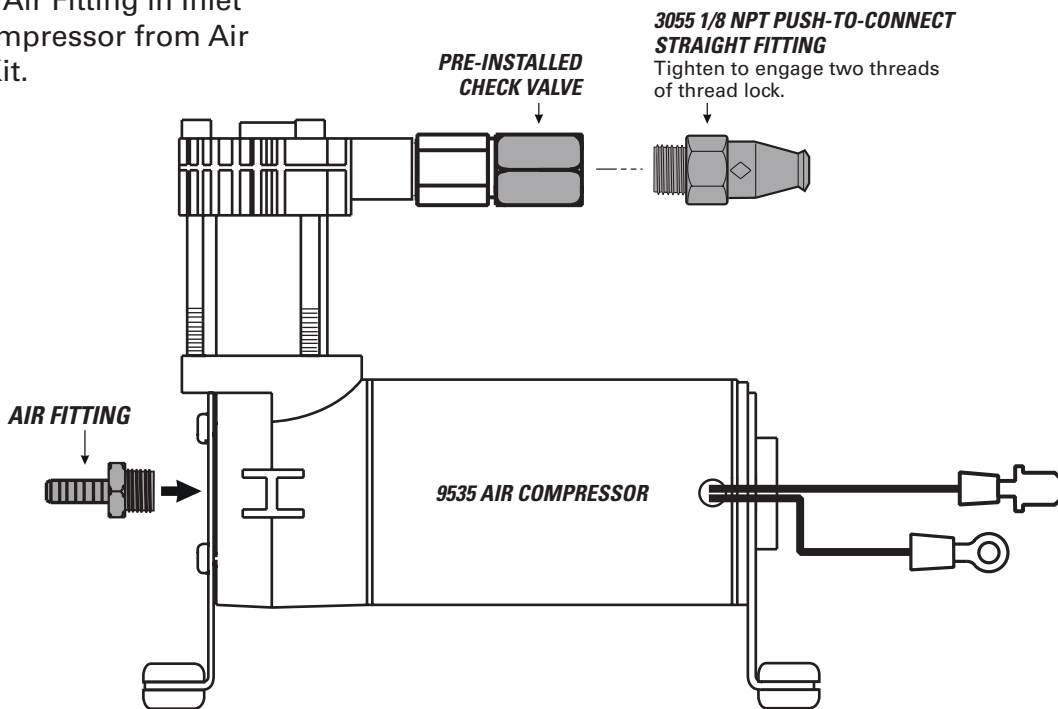

# 2

## DRILL HOLES FOR CONTROL PANEL INSTALLATION

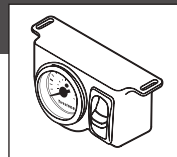

Use the location you selected during the Planning the Installation step on page 4.

- 1 Using the Control Panel slots as a template, mark two drill locations with a punch or marking tool.

- 2 Drill a 7/32" diameter hole on each center mark.

- 3 Do not mount the control panel until step 8.

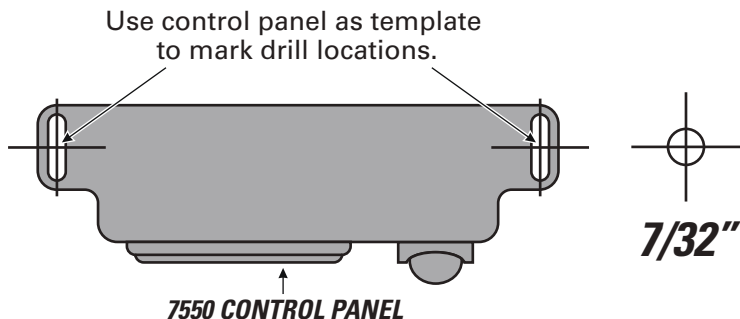

## OPTIONAL - DRILL HOLES FOR AIR COMPRESSOR INSTALLATION

3

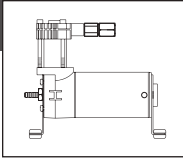

IF YOU ARE USING THE SUPPLIED FIRESTONE AIR ACCESSORY MOUNTING KIT, SKIP THIS STEP AND REFER TO THE MOUNTING KIT'S INSTRUCTIONS AT THE END OF THIS MANUAL..

**STOP HERE AND SKIP THIS STEP IF USING THE PROVIDED MOUNTING KIT**



CHECK SURROUNDING AREA AND BACK SIDE OF MOUNTING LOCATION TO AVOID DRILLING INTO EXISTING LINES OR WIRING.

**1** Using the Air Compressor as a template, mark four drill locations with a punch or marking tool.

**2** Mark ground wire fastening location within reach of the ground wire ring terminal.

**3** Drill 7/32" diameter holes. Remove any burrs and debris from drill holes..

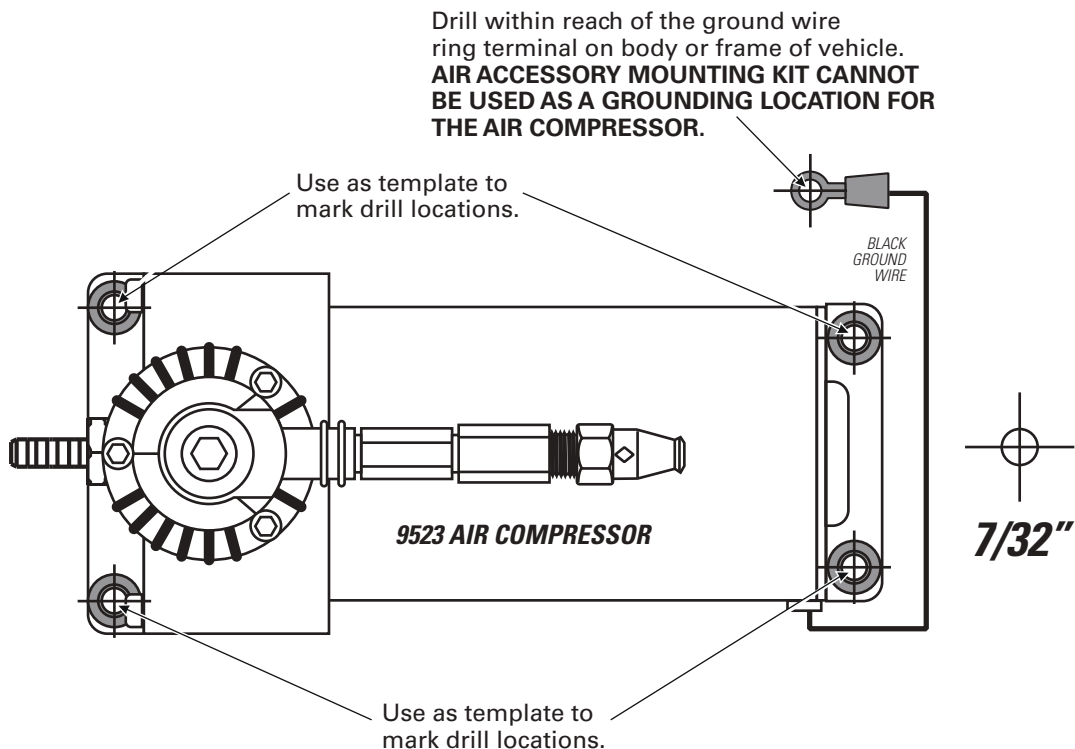

# 4

## INSTALL AIR COMPRESSOR

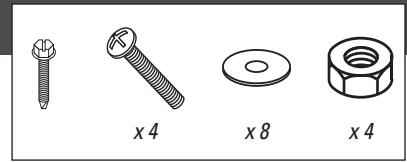

DO NOT OVER TIGHTEN MOUNTING BOLTS AND NUTS. TOO MUCH TORQUE CAN CRUSH THE BRASS INSERTS AND RUBBER ISOLATORS.

**1** Mount the Air Compressor to the hole locations on the provided Mounting Kit using the supplied fasteners. DO NOT OVERTIGHTEN.

**2** Mount the black ground wire ring terminal using the supplied fasteners. Assure that the ring terminal makes a solid contact with bare metal for a proper ground. (Optionally, you can run the negative wire to the negative battery terminal.)

**OPTIONAL** Mount to the drill holes made in the frame. Do this only if the mounting kit will not mount to the frame of the vehicle.

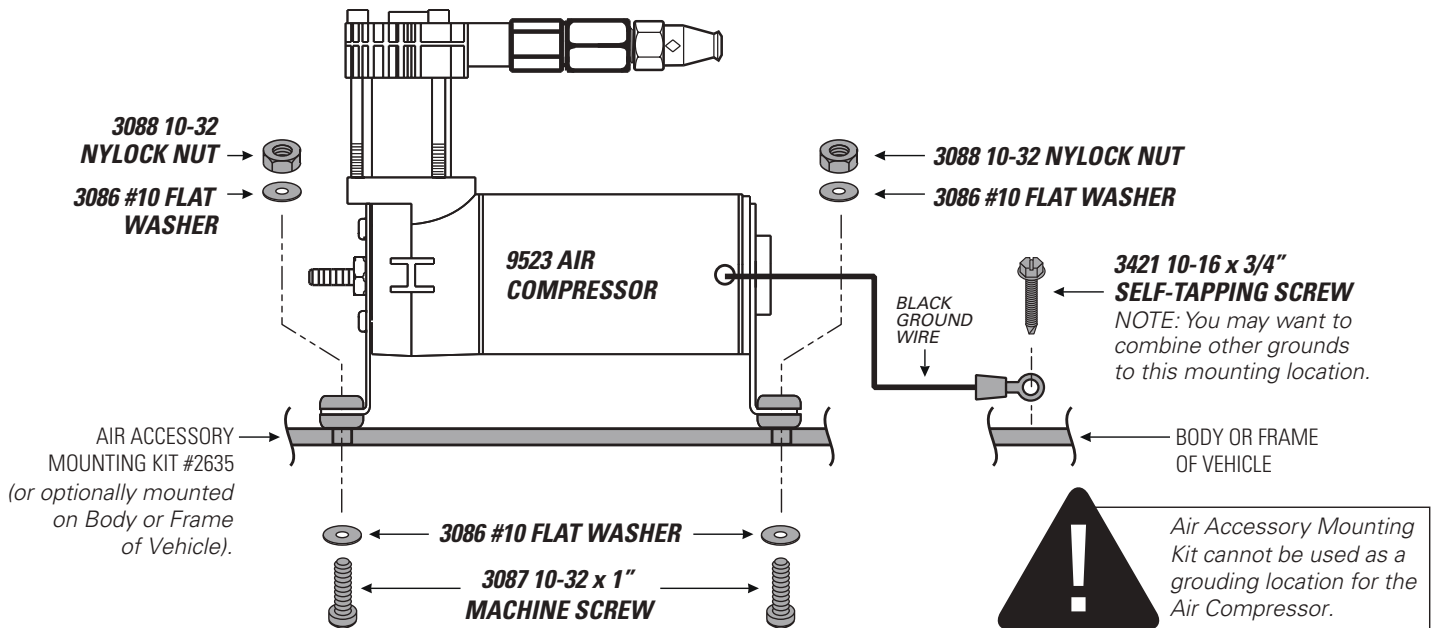

TO CREATE A PROPER GROUND, ASSURE THE GROUND RING TERMINAL CONTACTS BARE METAL AND IS FASTENED SECURELY. AFTER INSTALLATION, YOU MAY OPTIONALLY COAT THE RING TERMINAL IN SILICONE TO PROTECT IT FROM CORRODING.



Use the route you selected during the Planning the Installation step on page 4.

**1** Route the Air Tubing from the Air Compressor to the Control Panel, leaving room to secure line safely. Use guidelines below to cut.

**2** Install the Air Tubing end onto the Barbed Fitting on the back of the Control Panel switch as shown.

**3** Install the Air Tubing end into the 1/8 NPT Push-to-Connect Straight Fitting on the top of the Air Compressor.



EXHAUST ALL AIR FROM THE SYSTEM PRIOR TO RELEASING AIR TUBING FROM AIR FITTINGS.



FOR PROPER INSTALLATION, SOAK AIR LINE TUBE ENDS IN HOT WATER BEFORE INSTALLING ONTO BARBED FITTINGS.

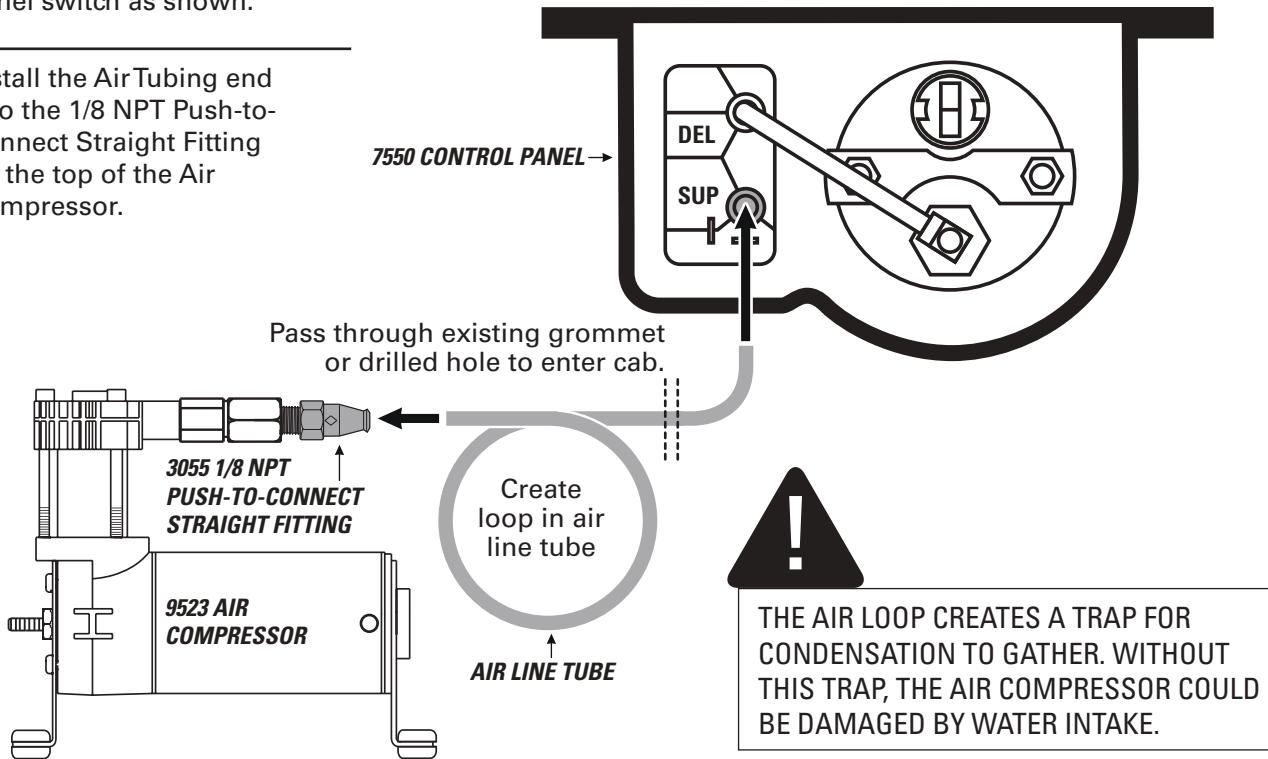

**DO**

Make sure the cut is as square as possible. Use a tube cutter or sharp utility knife.

**DON'T**

Fold or kink the Air Tubing. Cut the Air Tubing at an angle. Use pliers, scissors, snips, saws, or side cutters

**PROPER AND IMPROPER CUTS IN THE AIR LINE TUBE**

--	--	--	--

# 6

## INSTALL T-FITTING AND ROUTE AIR LINE TUBE TO CONTROL PANEL

Use the route you selected during the Planning the Installation step on page 4.

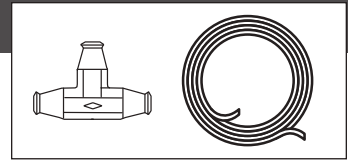

EXHAUST ALL AIR FROM THE SYSTEM PRIOR TO RELEASING AIR TUBING FROM AIR FITTINGS.



FOR PROPER INSTALLATION, SOAK AIR LINE TUBE ENDS IN HOT WATER BEFORE INSTALLING ONTO BARBED FITTINGS.

**1** Route the Air Tubing from the Control Panel to the Air Springs.

**2** Install the Air Tubing end onto the Barbed Fitting on the back of the Control Panel pressure gauge as shown.

**3** Determine a safe location for the Push-to-Connect T-fitting, where Air Tubing from the Air Springs and the Control Panel can safely meet.

**4** Install the Air Tubing from the Air Springs into opposite ends on the Push-to-Connect T-fitting, as shown.

**5** Install the Air Tubing from the Control Panel to the single end on the Push-to-Connect T-fitting.

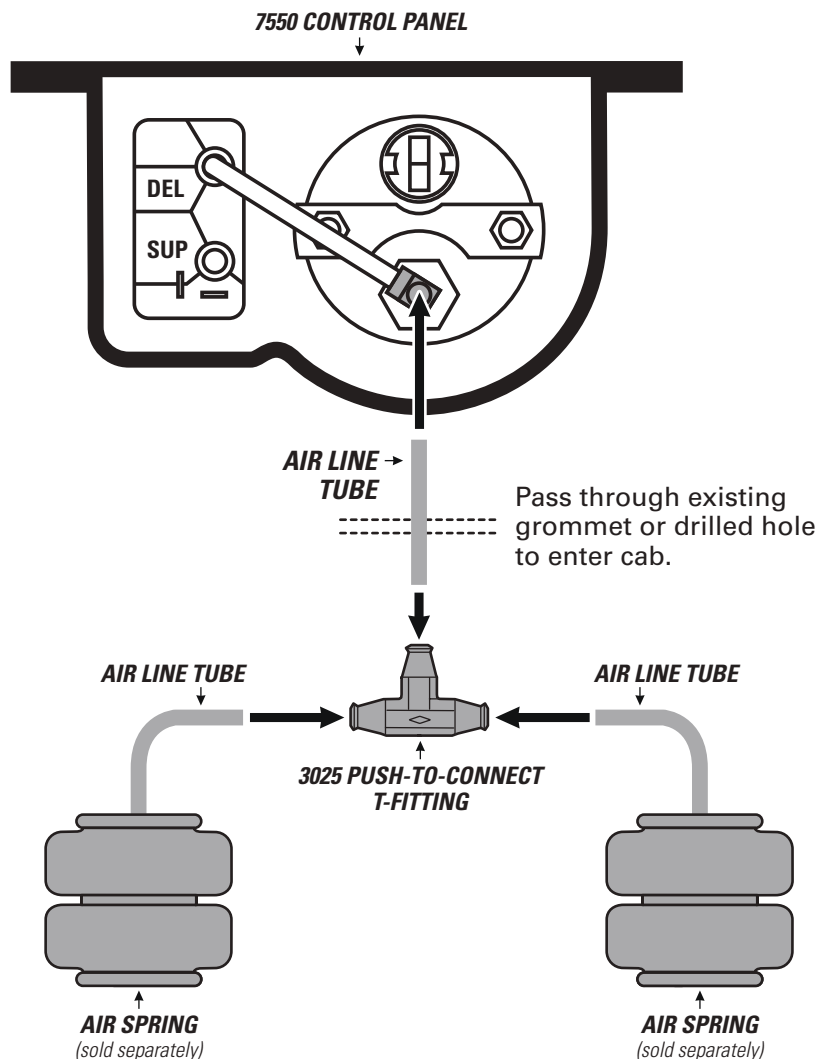

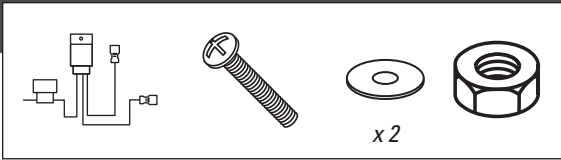

**1** Select a safe location within 3 feet of the Air Compressor.

**2** Use one of the unused holes on the Compressor Mounting Plate to mount the relay housing on the Relay Harness. Secure with fasteners shown.

**3** Route the white wire with the female spade connector labeled "switch panel" to the Control Panel.

Optionally: Mark and drill a 7/32" hole in the frame if unable to use mounting bracket.

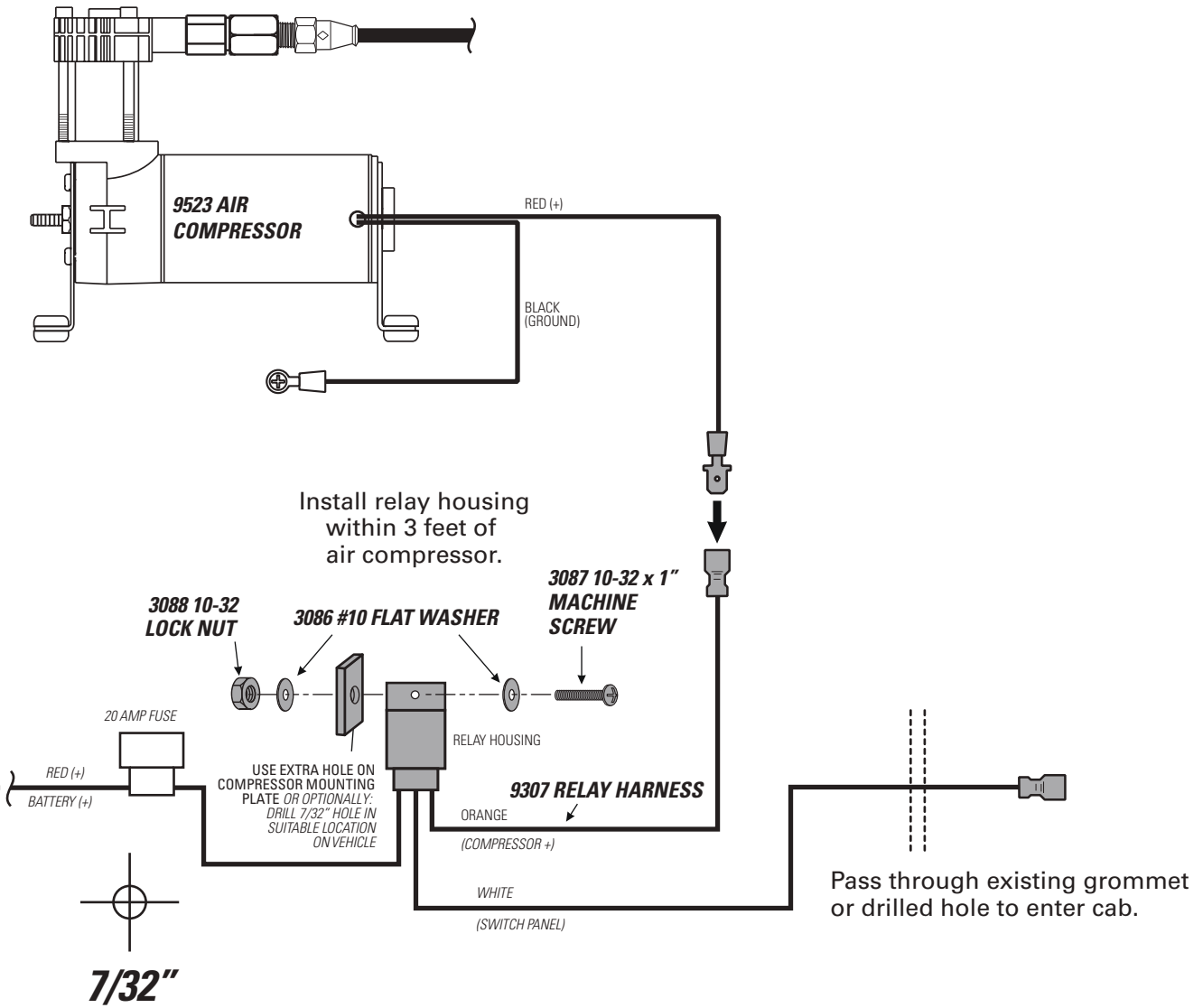

# 8

## FINISH WIRING AND INSTALLATION

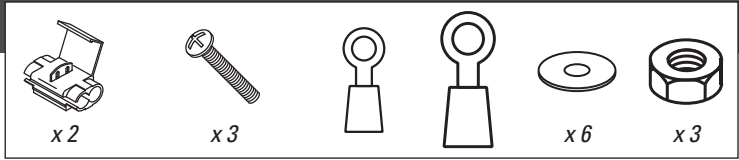

**1** Connect wires, install ring terminals and wire connectors as shown below.

**2** Fasten Control Panel ground wires to vehicle as shown.

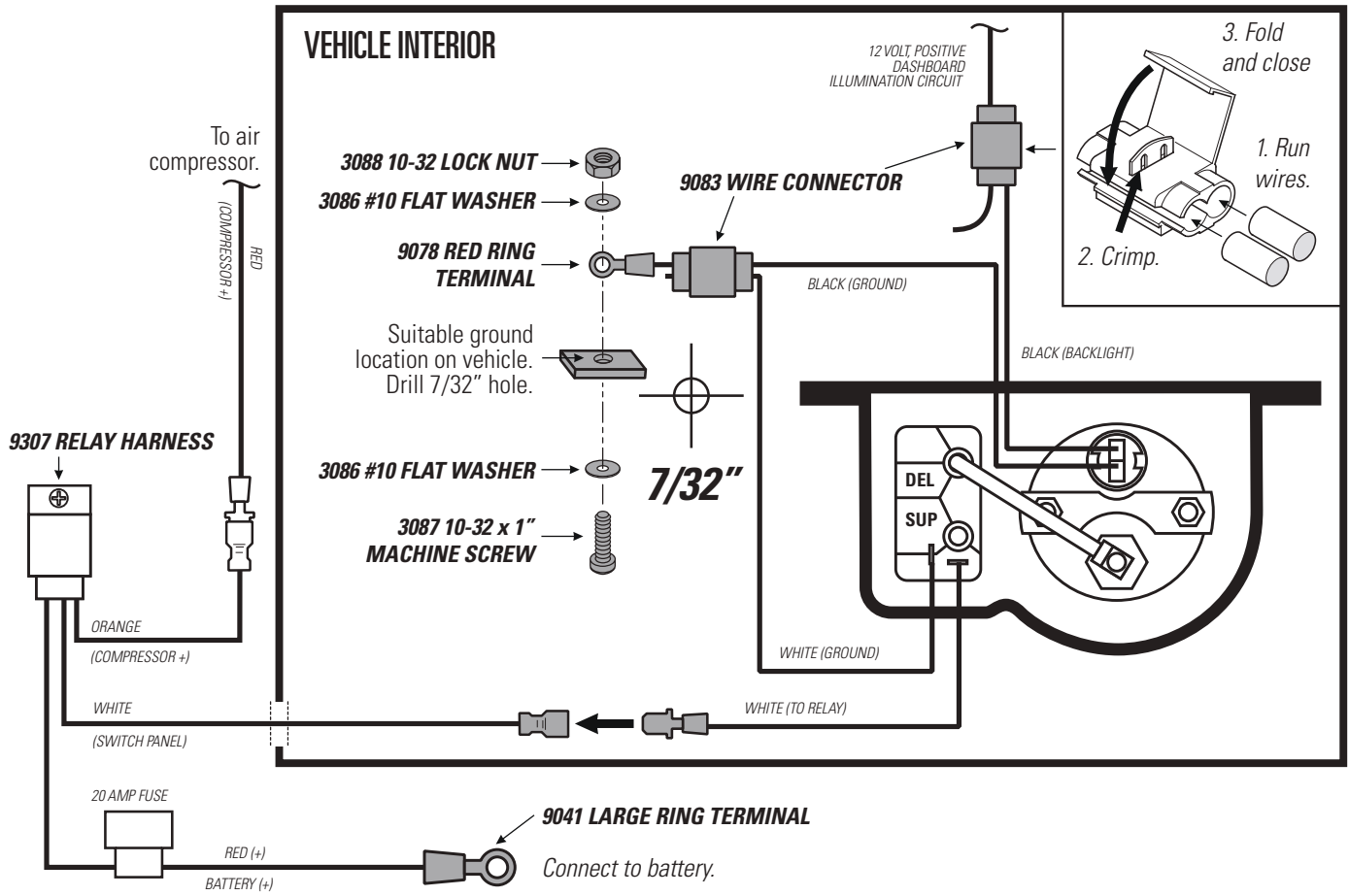

**3** Install the Control Panel using the supplied fasteners.

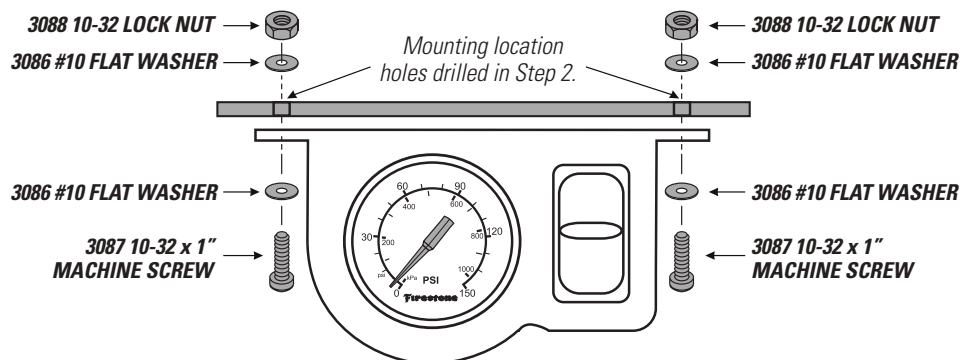



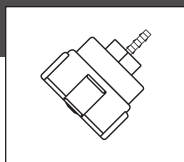

FILTER LIFE WILL VARY BASED ON ENVIRONMENTAL CONDITIONS. PROTECT THE AIR COMPRESSOR BY CHANGING THE AIR FILTER MORE FREQUENTLY IN DUSTY CONDITIONS.

- 1** Fully secure the Air Filter barb into the Air Tubing from the Air Compressor kit.
- 2** Press Air Tubing onto the barb on the Air Compressor Air Fitting until fully seated. Assure you create a loop in the Air Tubing, as shown, when securing it to the vehicle.
- 3** Periodically check the Air Filter during operation. When the Air Filter is dirty and needs to be replaced, contact an Authorized Firestone dealer to purchase a new one.

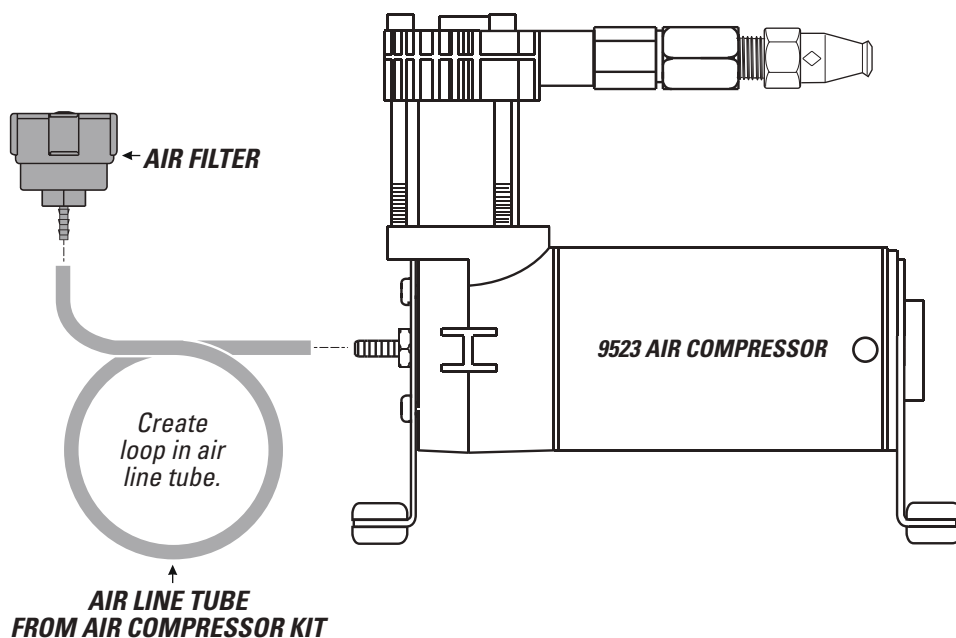

- 1** Clean up the installation using supplied Nylon ties, and return all factory parts and materials to operative state.



USING SUPPLIED NYLON TIES, SECURE ALL WIRING AND AIR LINE TUBE IN A MANNER THAT DOES NOT OBSTRUCT YOUR VIEW OR ABILITY TO SAFELY OPERATE THE VEHICLE.

# 11

## TEST THE SYSTEM

With the Air Command™ kit and your air springs installed, you are ready to test the system.

- 1 Reattach the negative battery cable.

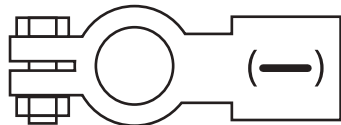

- 2 Turn on your vehicle's ignition.

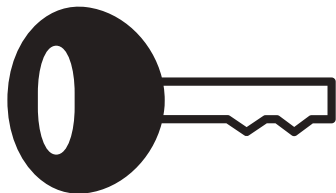

- 3 Push Paddle Switch up to inflate the Air Springs to 70 PSI.

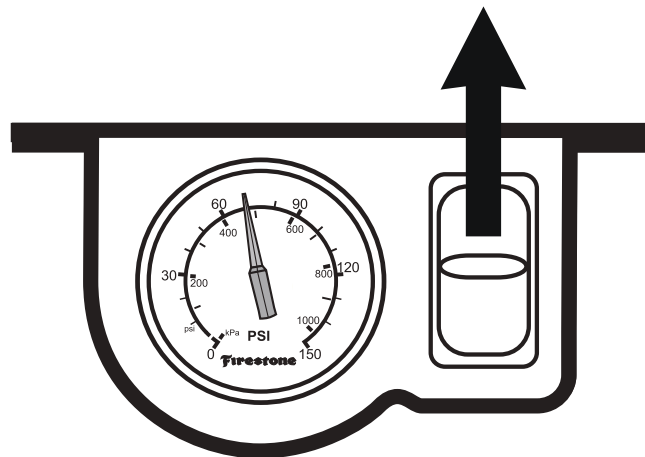

- 4 Spray fittings with soap and water mixture.



- 5 Observe bubbles.

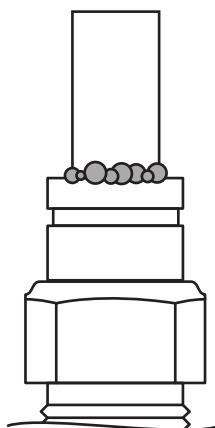

**SMALL SOAP BUBBLES  
THAT DO NOT EXPAND**

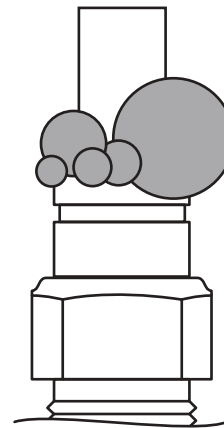

**SOAP BUBBLES  
THAT EXPAND**



# NO LEAKS?

Congratulations! You're riding right with the flip of a switch! Remember to review the Operating Instructions.

# LEAK?

Bummer. Continue to step 12 to fix the leak.



EXHAUST ALL AIR FROM THE SYSTEM PRIOR TO RELEASING AIR TUBING FROM AIR FITTINGS.



- 1** Push Paddle Switch down to release all air pressure from the Air Springs.

NOTE: While doing this, if you get a quick burst of air prior to the gauge dropping to 0 PSI, your lines are incorrectly swapped.

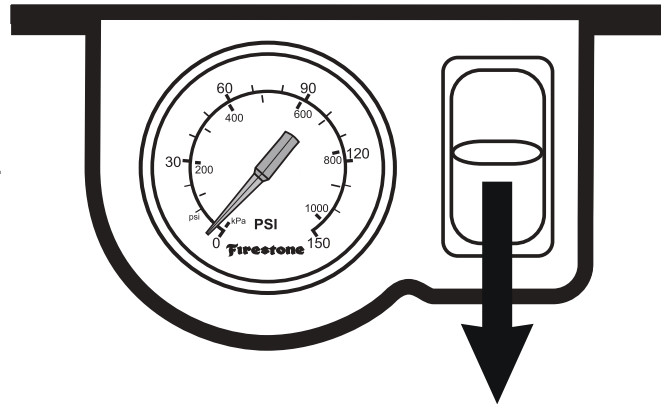

#### LEAK AT AIR LINE TUBE AND AIR FITTING

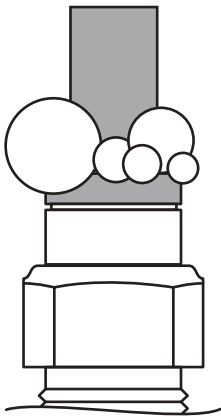

Release air line tube (see page 4). Review proper cuts and procedures in step 5. Repeat installation steps.

#### LEAK AT BASE OF AIR FITTING ON AIR SPRING

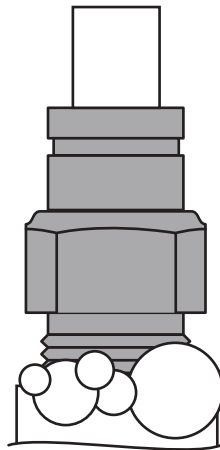

Tighten air fitting one turn or until leak stops.

#### LEAK AT A BARBED FITTING

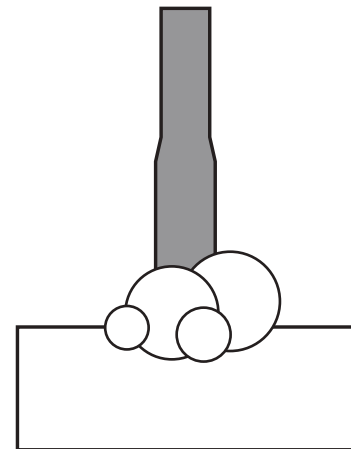

Being careful not to scar the metal barbs, cut away, check for debris. Trim air tube line, **soak for 5 minutes in hot water**. Reinstall.

## STILL HAVE A LEAK?

Refer to the Troubleshooting section of the Instruction Manual. If the leak persists, or if there is an issue with a leaking part, email us at [rrtech@fsip.com](mailto:rrtech@fsip.com). If emailing, please include photos to help us better diagnose and understand any problems you may be experiencing.



# AIRIDE

[firestoneairide.com](http://firestoneairide.com)

## BEFORE YOU DRIVE, CONFIRM THE FOLLOWING:

- Secure all air line tubes and wiring inside the cab and on the outside of the truck.
- Make sure no wiring, air line tubes, or hardware obstruct your vision or ability to safely operate the vehicle.
- The system passes the leak test and holds air.
- The air compressor ground ring terminal is contacting bare metal, and coated with silicone if possible.
- There is a loop in the air line tubes as shown to prevent water or debris from getting into the air compressor head and damaging it.
- The air gauge backlight turns off when the ignition is off, or when dashboard lights do not illuminate.
- Put a minimum of 5 PSI in the air springs, unloaded.

## NEED INSTALLATION HELP?

Email us at [rrtech@fsip.com](mailto:rrtech@fsip.com). Please include photos, kit number, and the year, make, and model of the vehicle to help us better diagnose and understand any problems you may be experiencing.

CONNECT WITH US



@FirestoneAiride



FirestoneAiride



Firestone Airide



**AIRIDE**

[firestoneairide.com](http://firestoneairide.com)

# INSTALLATION INSTRUCTIONS

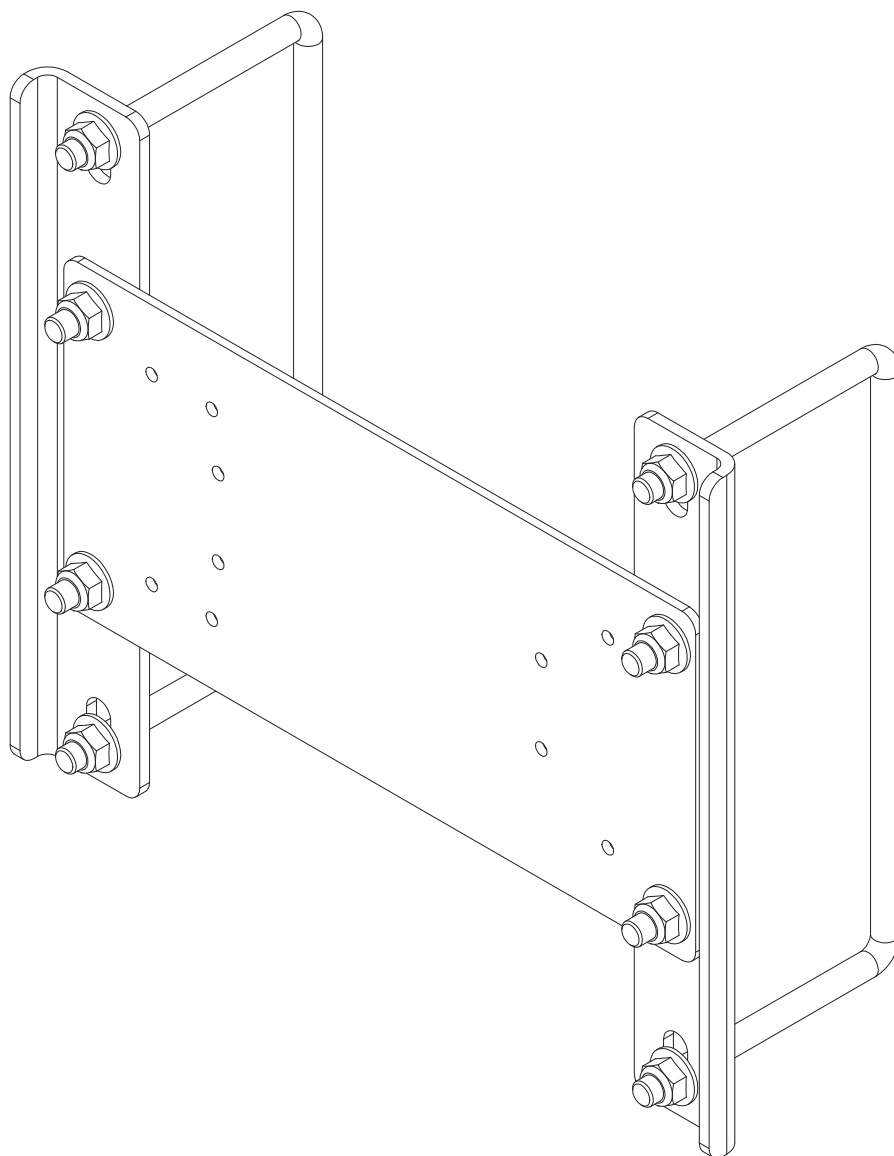

# ! IMPORTANT

PLEASE DON'T HURT YOURSELF, YOUR KIT OR YOUR VEHICLE. TAKE A MINUTE TO READ THIS IMPORTANT INFORMATION.

DO NOT INSTALL IF THE TRUCK HAS BEEN LIFTED AND THE STOCK JOUNCE BUMPER SPACERS ARE NOT ON THE VEHICLE. *This kit is to be used on a pickup truck only, and DOES NOT INCREASE YOUR VEHICLE'S MAXIMUM LOAD.*

## SAFE INSTALLATION

Please take all safety precautions during installation. A hydraulic jack can fail, and if that happens, you can be seriously hurt, or worse, if you are relying on it to hold up the vehicle. If you use a hydraulic jack, secure jack stands in the appropriate locations and chock any tires still touching the ground.

Wear safety glasses or goggles. Your eyes may be lower than some parts and pieces, and you don't want to lose an eye.

Remove the possibility of any electrical issues by disconnecting the negative battery cable.

## KIT USES

This kit works with Air Command Kits 2900, 2901, 2910, and 2911. Refer to the following pages for kit-specific layouts to ensure proper fitment.

## VEHICLE GVWR

NEVER exceed the maximum load recommended by the vehicle manufacturer (GVWR). The GVWR can be found in your vehicle's owner's manual or on the data plate on the driver's side door.

## INFLATING THE AIR SPRINGS

When inflating air springs, add air pressure in small quantities, checking air pressure frequently. The air springs have much less air volume than a tire, so they inflate much more quickly.



## APPROPRIATE AIR PRESSURE

For best ride, use only enough air pressure in the air springs to level the vehicle when viewed from the side (front to rear). This will vary, depending on the load, location of the load, condition of the existing suspension, and personal preference.

# PARTS

Compare the parts below to your kit. Ensure you have all pieces, and organize them for an easier installation.

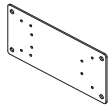
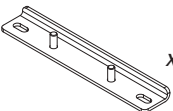
## MAIN KIT CONTENTS

PT # 5970	 x1	COMPRESSOR MOUNTING PLATE	PT # 5705	 x2	AIR ACCESSORY FRAME BRACKET	PT # 3414	 x2	BAIL CLAMP
-----------	--	---------------------------	-----------	--	-----------------------------	-----------	--	------------

## A21-760-2497 HARDWARE PACK

PT # 3067	 x8	3/8"-16 HEX HEAD FLANGE NYLOCK NUT
-----------	--	------------------------------------

**1** Secure the Compressor Mounting Plate to the System Frame Brackets shown below.

**2** Select a suitable location for installation on the vehicle frame rail.

It is recommended to mount to the passenger side frame rail as the vehicle's battery is normally located in the engine compartment on the passenger side. Double check before final installation.

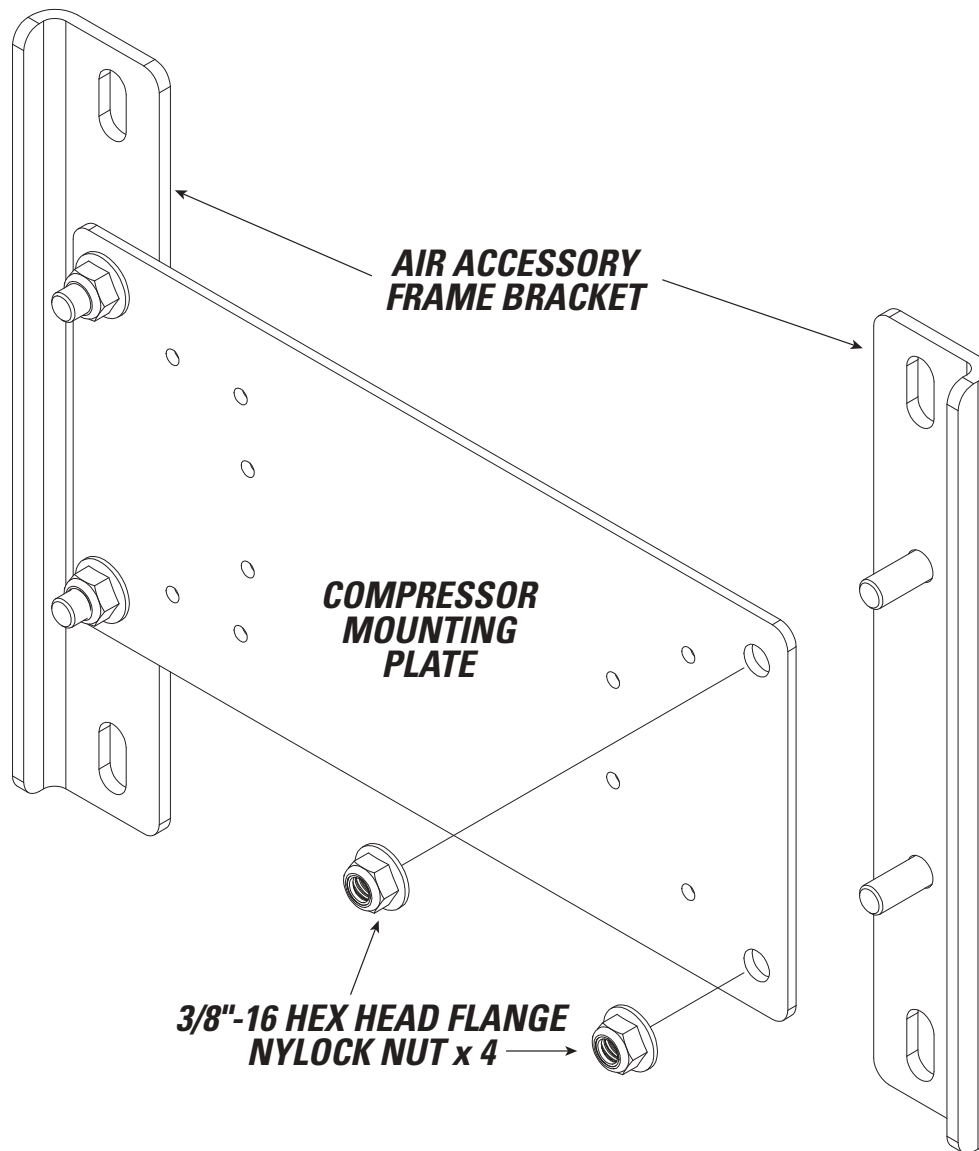

# 2

## INSTALL THE AIR COMPRESSOR - USE FOR STANDARD DUTY AIR COMMAND KITS 2900 & 2910

Fasteners included in Air Command Kit



x 4



x 8



x 4



DO NOT OVERTIGHTEN MOUNTING BOLTS AND NUTS ON THE AIR COMPRESSOR. TOO MUCH TORQUE CAN CRUSH THE BRASS INSERTS AND RUBBER ISOLATORS.

**1** Mount the Air Compressor to the hole locations in the Compressor Plate using the supplied fasteners. DO NOT OVERTIGHTEN.

**2** It is recommended to face the outlet of the compressor towards the air springs on the rear axle of vehicle.

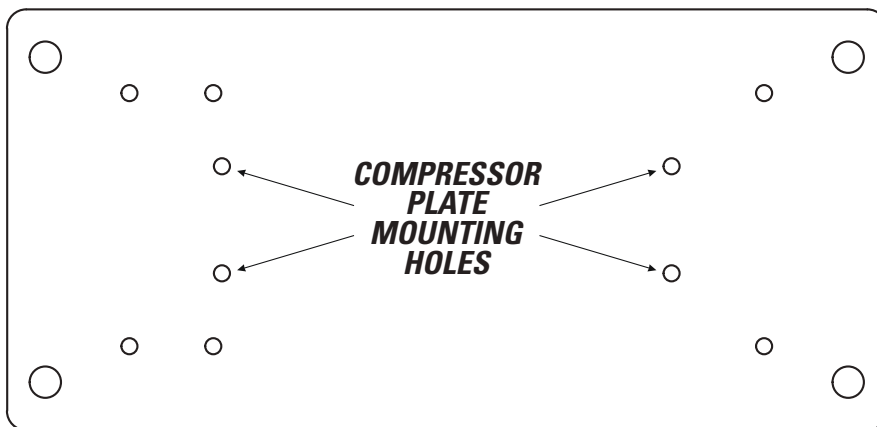
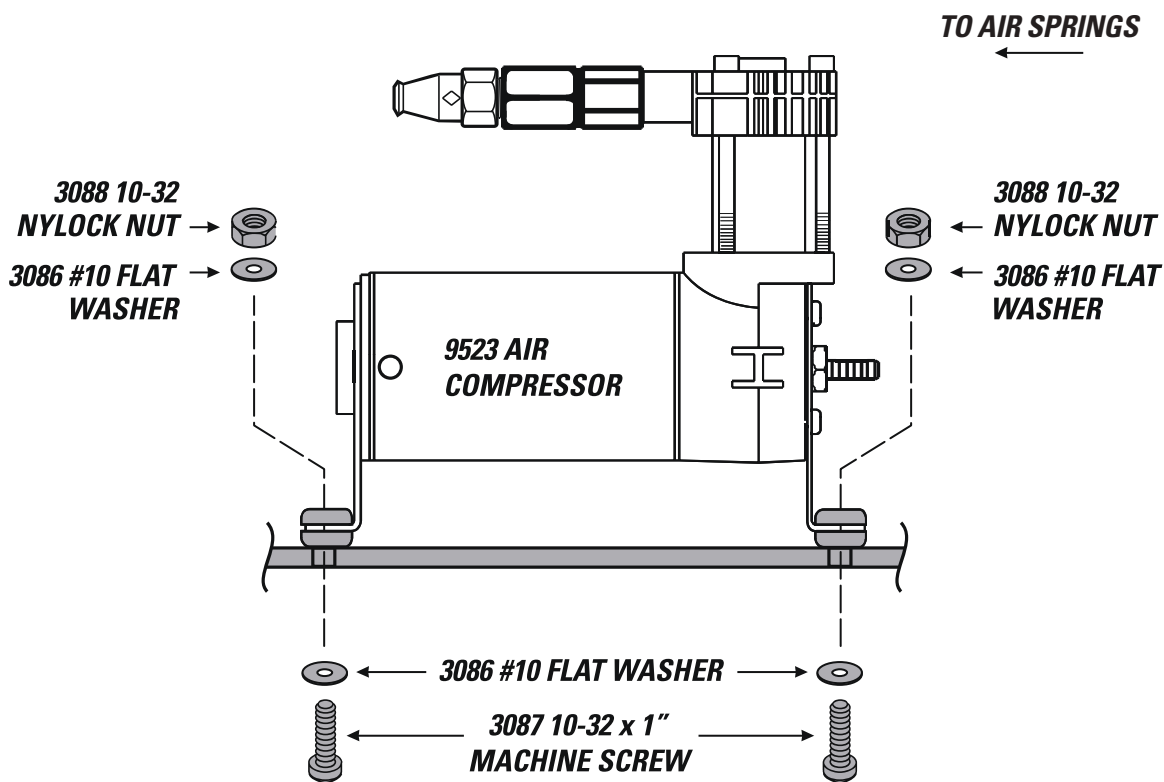





AIR ACCESSORY MOUNTING KIT CANNOT BE USED AS A GROUNDING LOCATION FOR THE AIR COMPRESSOR

**1** Install the compressor mounting assembly to the vehicle's frame rail, using the provided Bail Clamps.

RECOMMENDED

**2** Continue following the Air Command Kit instructions to connect all air tubing and electrical wiring.

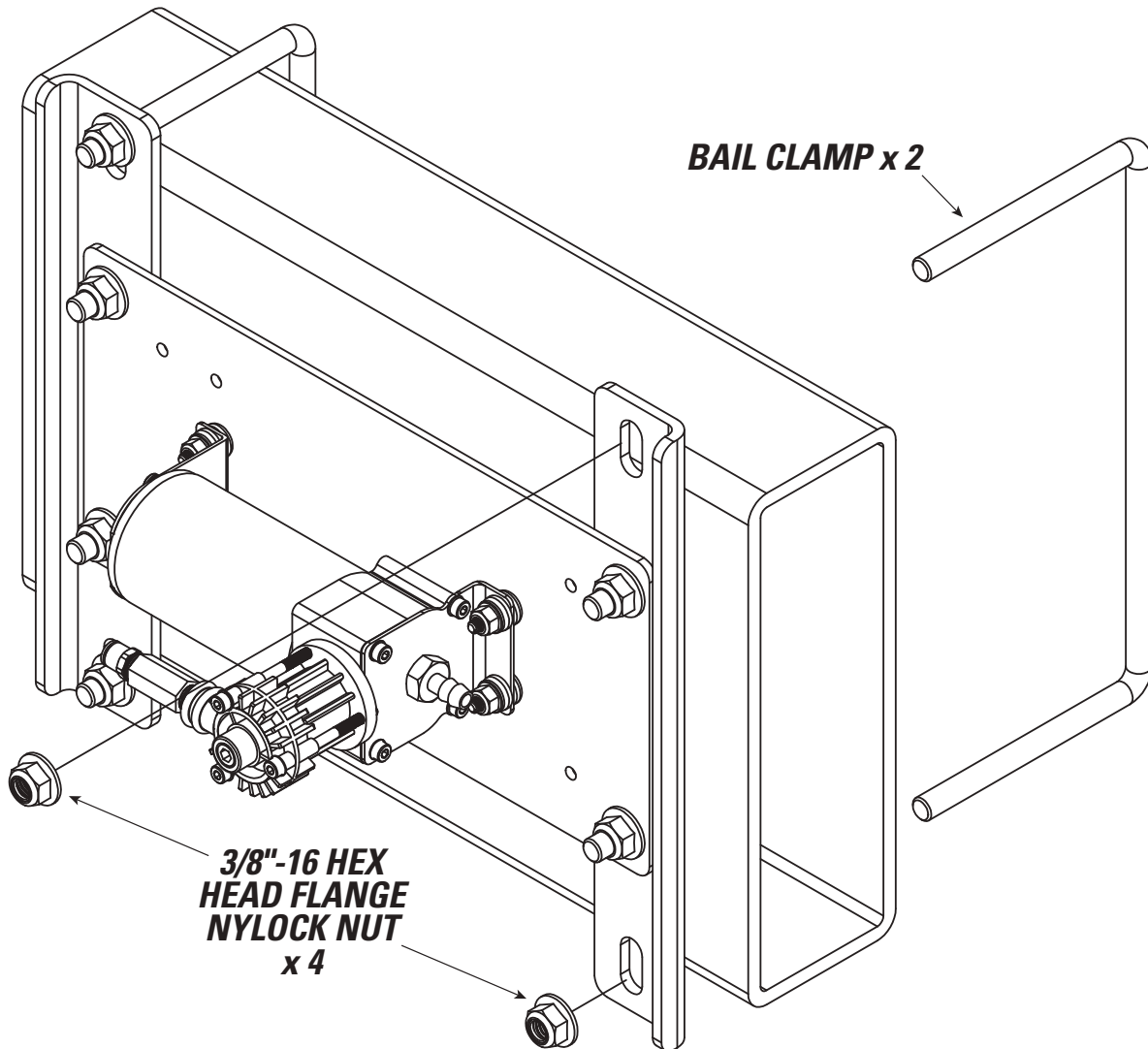





# AIRIDE

[firestoneairide.com](http://firestoneairide.com)

## BEFORE YOU DRIVE, CONFIRM THE FOLLOWING:

- Make sure all fasteners are tight and secure.
- Make sure the installation does not interfere with any other components on the vehicle.
- Reattach negative battery cable.

## NEED INSTALLATION HELP?

Email us at [rrtech@fsip.com](mailto:rrtech@fsip.com). Please include photos, kit number, and the year, make, and model of the vehicle to help us better diagnose and understand any problems you may be experiencing.

CONNECT WITH US



@FirestoneAiride



FirestoneAiride



Firestone Airide