

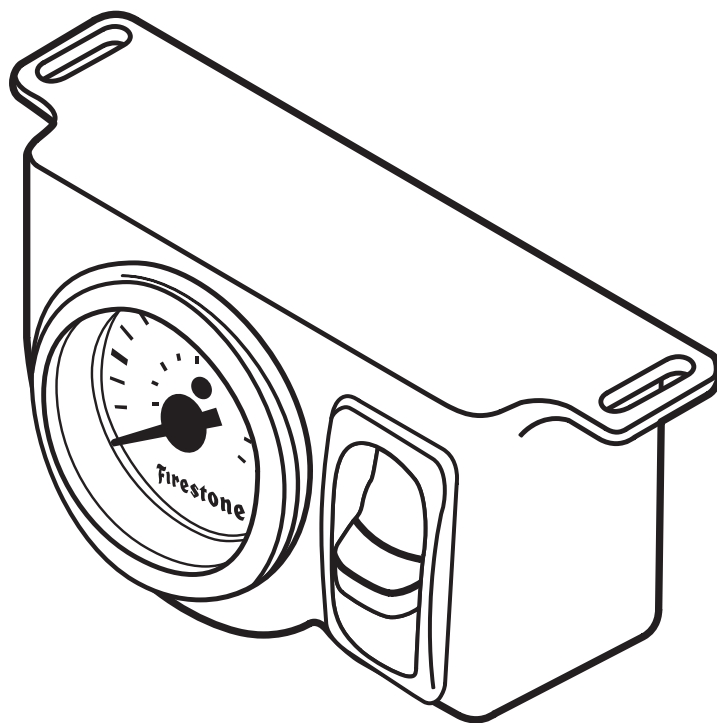

**AIRIDE**

[firestoneairide.com](http://firestoneairide.com)

# INSTALLATION INSTRUCTIONS



# ! IMPORTANT

*PLEASE DON'T HURT YOURSELF, YOUR KIT OR YOUR VEHICLE. TAKE A MINUTE TO READ THIS IMPORTANT INFORMATION.*

## **SAFE INSTALLATION**

Please take all safety precautions during installation. A hydraulic jack can fail, and if that happens, you can be seriously hurt, or worse, if you are relying on it to hold up the vehicle. If you use a hydraulic jack, secure jack stands in the appropriate locations and chock any tires still touching the ground.

Wear safety glasses or goggles. Your eyes may be lower than some parts and pieces, and you don't want to lose an eye.

Remove the possibility of any electrical issues by disconnecting the negative battery cable.

## **VEHICLE GVWR**

NEVER exceed the maximum load recommended by the vehicle manufacturer (GVWR). The GVWR can be found in your vehicle's owner's manual or on the data plate on the driver's side door. Consult your local dealership for additional GVWR specifications.

## **INFLATING THE AIR SPRINGS**

When inflating air springs, add air pressure in small quantities, checking air pressure frequently. The air springs have much less air volume than a tire, so they inflate much more quickly.

## **PRESSURE TO LOAD**

Be sure to review the load limits noted in the Air Spring Kit Installation Instructions (sold separately).

## **APPROPRIATE AIR PRESSURE**

For best ride, use only enough air pressure in the air springs to level the vehicle when viewed from the side (front to rear). This will vary, depending on the load, location of the load, condition of the existing suspension, and personal preference.



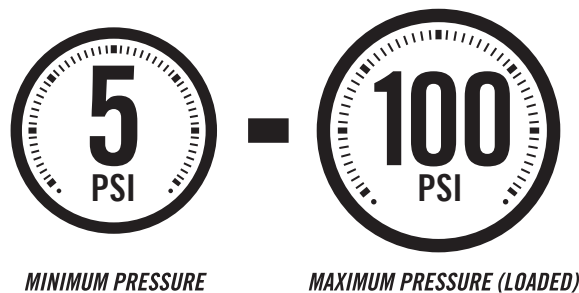

***ONCE INSTALLED SUCCESSFULLY, FOLLOW THE PRESSURE REQUIREMENTS FOR THE AIR SPRINGS:***





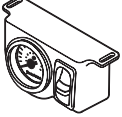
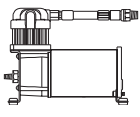
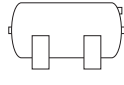

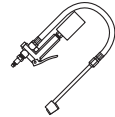















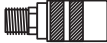

# PARTS

Compare the parts below to your kit. Ensure you have all pieces, and organize them for an easier installation.

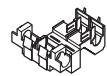
## MAIN KIT CONTENTS

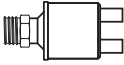
PT # 7551	 x1	SINGLE AIR CONTROL PANEL	PT # 9287	 x1	AIR COMPRESSOR 450C	PT # 9420	 x1	AIR TANK 2 GALLON
PT # 9416	 x1	AIR LINE TUBE (30 FEET)	PT # 9194	 x1	EXTERNAL HOSE	PT # 9195	 x1	INFLATOR AND GAUGE KIT
PT # 9301	 x1	STORAGE BAG HEAVY DUTY	<h3>A24-760-2636 COMPRESSOR AND TANK MOUNTING KIT</h3> <p>KIT # 2636  x1 COMPRESSOR AND TANK MOUNTING KIT</p> <p>The parts list for this kit is in the Mounting Kit Manual included at the end of this Manual.</p>					

## A21-760-2902 HARDWARE PACK

PT # 3087	 x7	10-32 x 1" MACHINE SCREW	PT # 3083	 x1	1/4 NPT FEMALE 1/4 PTC	PT # 9078	 x1	RED RING TERMINAL
PT # 3088	 x7	10-32 LOCK NUT	PT # 3046	 x3	1/4 STRAIGHT FITTING PTC	PT # 9086	 x2	SPADE TERMINAL FEMALE (22-18 GAUGE)
PT # 3086	 x14	#10 FLAT WASHER	PT # 3025	 x3	PUSH-TO-CONNECT T-FITTING	PT # 9132	 x2	SPADE TERMINAL FEMALE (16-14 GAUGE)
PT # 3421	 x1	10-16 x 3/4" SELF-TAPPING SCREW	PT # 9196	 x1	DRY COUPLER FITTING	PT # 9117	 x2	SPADE TERMINAL MALE (22 - 18 GAUGE)
PT # 0070	 x4	3/8-16 x 1.00 HEX HEAD CAP SCREW GR2	PT # 3146	 x1	1/4 NPT ANCHOR COUPLING	PT # 9131	 x2	SPADE TERMINAL MALE BLUE (16-14 GAUGE)
PT # 0071	 x4	3/8 FLAT WASHER	PT # 9040	 x1	FUSE ATO/ATC 30 AMP	PT # 9116	 x1	FUSE HOLDER SPADE TYPE
PT # 3087	 x4	3/8-16 HEX HEAD FLANGE CENTER LOCK NUT	PT # 9402	 x1	SEALED PRESSURE SWITCH 110/145	PT # 9083	 x2	WIRE CONNECTOR
PT # 9036	 x15	NYLON TIE	PT # 9136	 x1	15' 16 GAUGE RED WIRE	PT # 9082	 x1	15' 18 GAUGE RED WIRE

# CONTENTS AND OVERVIEW

PAGE 4	PLANNING THE INSTALL
PAGE 5	PREPARE AIR COMPRESSOR & CONTROL PANEL
PAGE 6	DRILL HOLES FOR AIR COMPRESSOR INSTALLATION
PAGE 7	INSTALL THE AIR COMPRESSOR
PAGE 8	AIR COMPRESSOR TO CONTROL PANEL AIR LINE TUBE
PAGE 9	AIR SPRINGS TO CONTROL PANEL AIR LINE TUBE
PAGE 10	INSTALL RELAY HARNESS
PAGE 11	FINISH CONTROL PANEL WIRING & INSTALLATION
PAGE 12	INSTALL THE AIR FILTER & CLEAN UP INSTALLATION
PAGE 13	TEST THE SYSTEM
PAGE 14	FIXING AN AIR LEAK

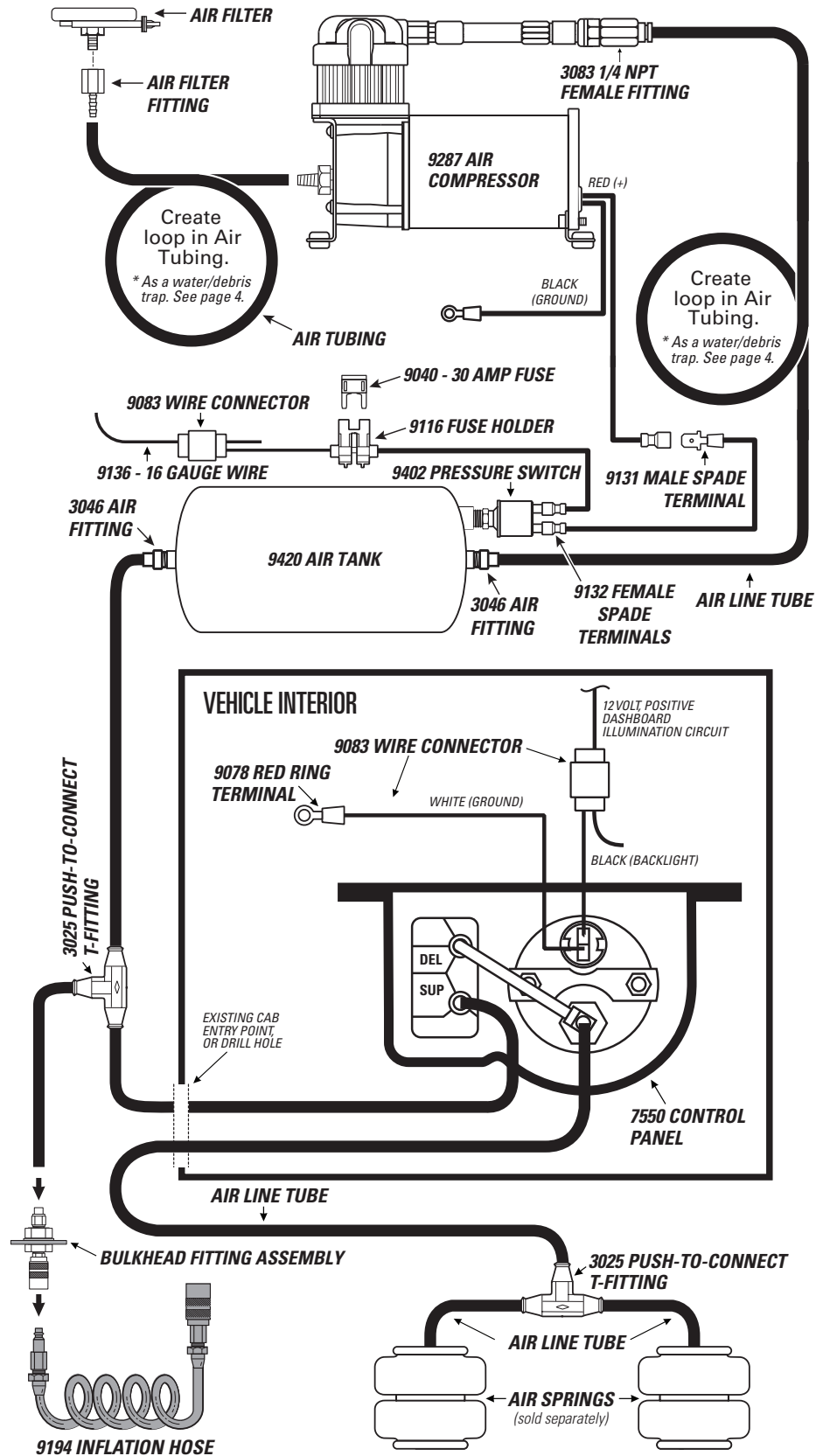

# PLANNING THE INSTALL

THESE PLANNING STEPS WILL HELP YOU SAVE TIME AND WILL MAKE THE INSTALLATION EASIER.

## **DETERMINE THE MOUNTING LOCATION FOR THE CONTROL PANEL**

- Mount inside the vehicle cab, in a place where you will not hit or kick it.
- Allow room for the air line tube to run without sharp curves or bends.
- Do not obstruct your view or ability to safely operate the vehicle.

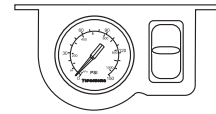

## **DETERMINE THE MOUNTING LOCATION FOR THE AIR COMPRESSOR**

- Use the provided Mounting Kit (Part # 2636) to mount the Compressor, considering the guidelines below, and follow the kit's instructions.
- Provide ample air flow.
- Protect from airborne debris and moisture.
- Optionally you can drill holes to mount the compressor to the frame, see Section 3

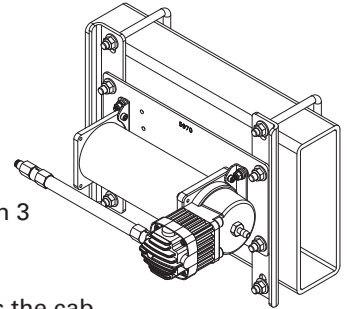

## **PLAN INSTALLATION ROUTES FOR WIRING AND AIR LINES INTO CAB**

- If possible, use existing factory grommet, such as where a wiring harness enters the cab.
- If not possible, drill a hole large enough for two air line tubes and a ground wire. Make sure the wiring and air line tubes are not exposed to sharp metal edges that can damage them.

## **SOAK AIR LINE TUBE ENDS IN HOT WATER BEFORE INSTALLING ONTO BARBED FITTINGS**

- The hot water makes the air line tube easier to work with and enables it to shrink onto the barbed fitting for a better seal.



## **TAPE ALL ELECTRICAL CONNECTIONS**

- Use electrical tape to appropriately secure and protect all electrical connections.

## **USING PUSH-TO-CONNECT FITTINGS FOR AIR LINES**

Your kit includes push-to-connect fittings to connect the air line tubes to hardware. Use the instructions below when using the air line.

- 1** Insert end of air line tube into air fitting.

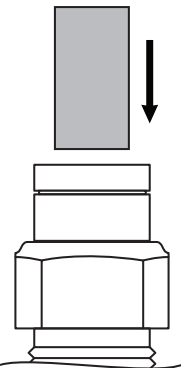

- 2** Push air line tube into air fitting as far as possible.

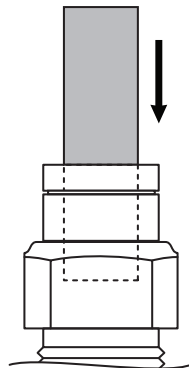

- 3** Gently pull on the air line tube to check for a secure fit.

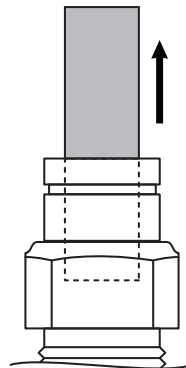

- 4** To remove, push down collar and gently pull air line tube away.

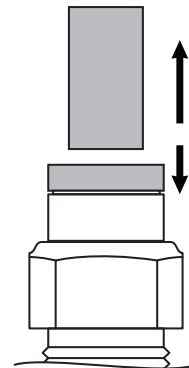

**Removal Tip:** Use a 1/4", 5/16", or 6mm open-ended wrench to push the collar down.

# 1

## PREPARE THE AIR COMPRESSOR AND TANK

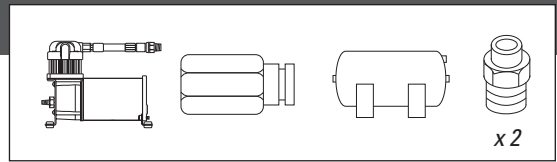

**1** Install 1/4 Female NPT Push-to-Connect Straight Fitting on the Check Valve.

**2** Install Barbed Air Fitting in Inlet Port of the Compressor from Air Compressor Kit.

**3** Install 1/4 Male NPT Push-to-Connect Straight Fittings on both ends of tank.

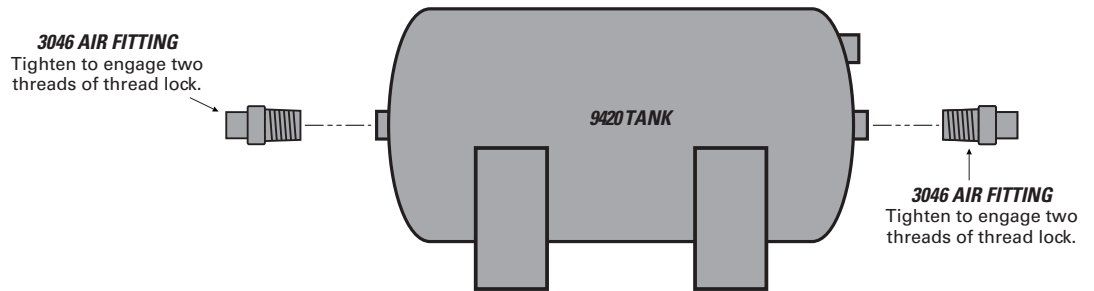
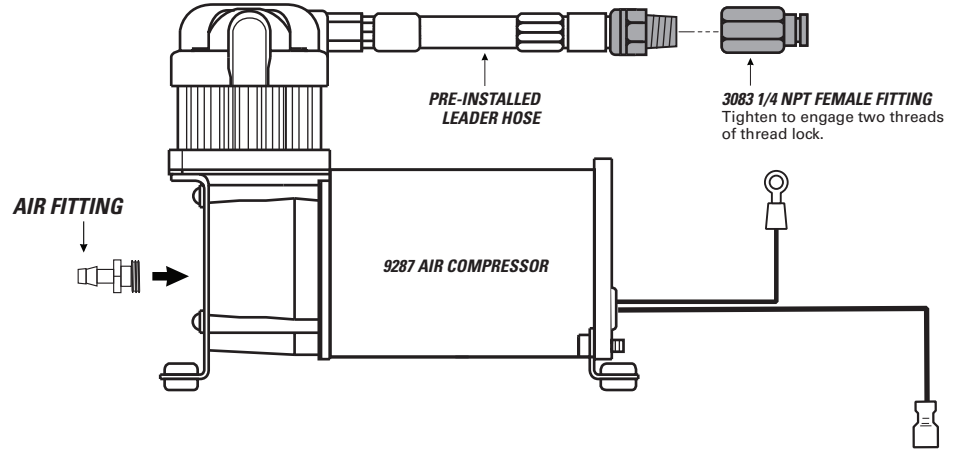

# 2

## DRILL HOLES FOR CONTROL PANEL INSTALLATION

Use the location you selected during the Planning the Installation step on page 4.



**1** Using the Control Panel slots as a template, mark two drill locations with a punch or marking tool.

**2** Drill a 7/32" diameter hole on each center mark.

**3** Do not mount the control panel until step 8.

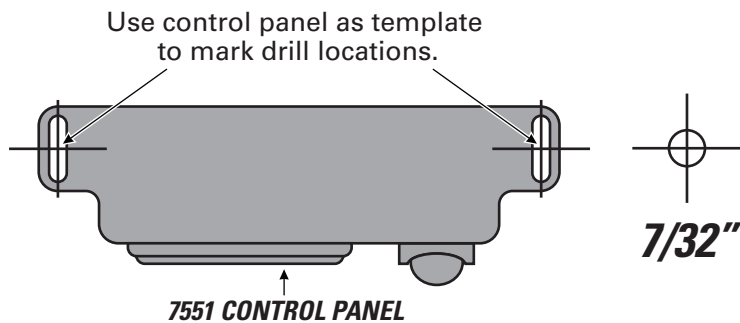

## OPTIONAL - DRILL HOLES FOR AIR COMPRESSOR INSTALLATION

3

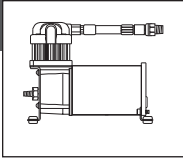

IF YOU ARE USING THE SUPPLIED FIRESTONE AIR ACCESSORY MOUNTING KIT, SKIP THIS STEP AND REFER TO THE MOUNTING KIT'S INSTRUCTIONS AT THE END OF THIS MANUAL..

### STOP HERE AND SKIP THIS STEP IF USING THE PROVIDED MOUNTING KIT



CHECK SURROUNDING AREA AND BACK SIDE OF MOUNTING LOCATION TO AVOID DRILLING INTO EXISTING LINES OR WIRING.

- 1 Using the Air Compressor as a template, mark four drill locations with a punch or marking tool.
- 2 Mark ground wire fastening location within reach of the ground wire ring terminal.
- 3 Drill 7/32" diameter holes. Remove any burrs and debris from drill holes..

Drill within reach of the ground wire ring terminal on body or frame of vehicle or create a wire to link to the negative battery terminal. Minimum gauge of wire should be 12.

**AIR ACCESSORY MOUNTING KIT CANNOT BE USED AS A GROUNDING LOCATION FOR THE AIR COMPRESSOR.**

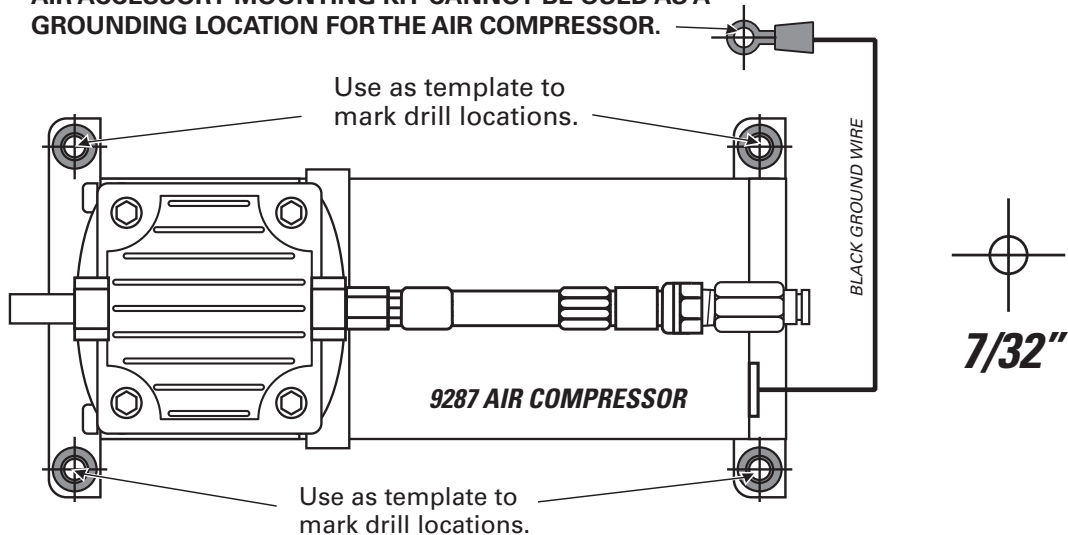

# 4

## INSTALL AIR COMPRESSOR AND TANK

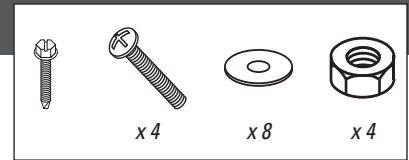

DO NOT OVER TIGHTEN MOUNTING BOLTS AND NUTS. TOO MUCH TORQUE CAN CRUSH THE BRASS INSERTS AND RUBBER ISOLATORS.

**1** Mount the Air Compressor to the hole locations on the provided Mounting Kit using the supplied fasteners. DO NOT OVERTIGHTEN.

**2** Mount the black ground wire ring terminal using the supplied fasteners. Assure that the ring terminal makes a solid contact with bare metal for a proper ground. (Optionally, you can run the negative wire to the negative battery terminal.)

**OPTIONAL** Mount to the drill holes made in the frame. Do this only if the mounting kit will not mount to the frame of the vehicle.

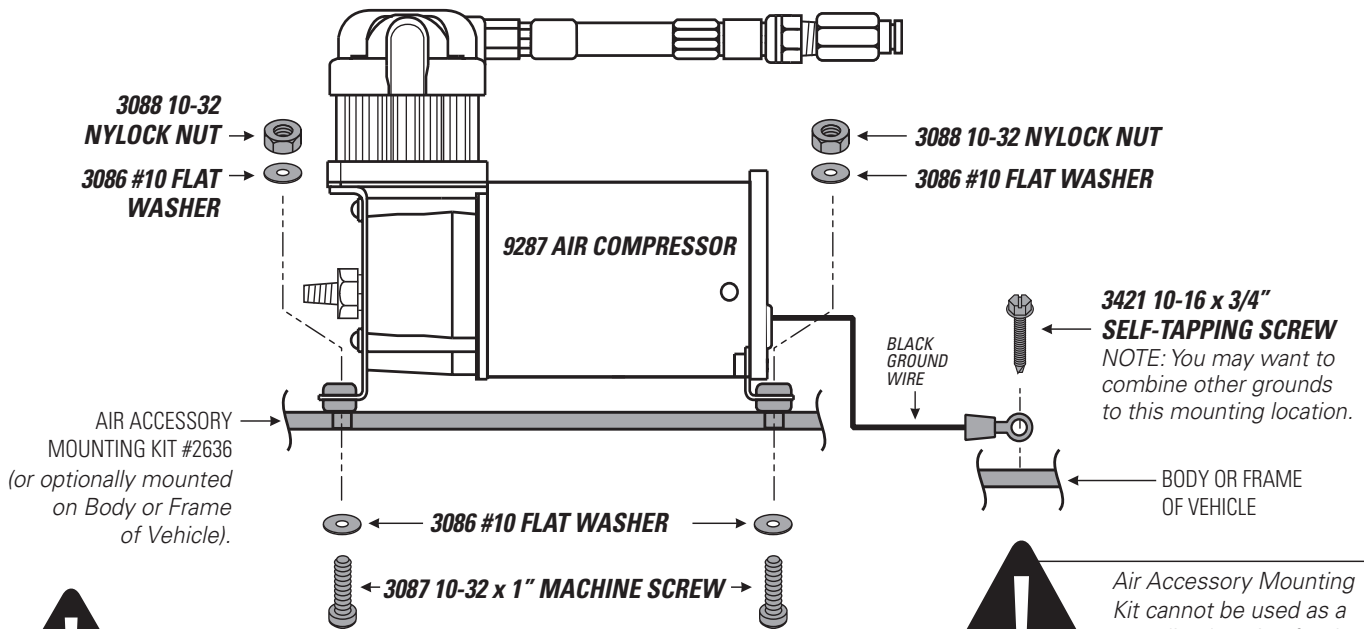

Air Accessory Mounting Kit cannot be used as a grounding location for the Air Compressor.

TO CREATE A PROPER GROUND, ASSURE THE GROUND RING TERMINAL CONTACTS BARE METAL AND IS FASTENED SECURELY. AFTER INSTALLATION, YOU MAY OPTIONALLY COAT THE RING TERMINAL IN SILICONE TO PROTECT IT FROM CORRODING.

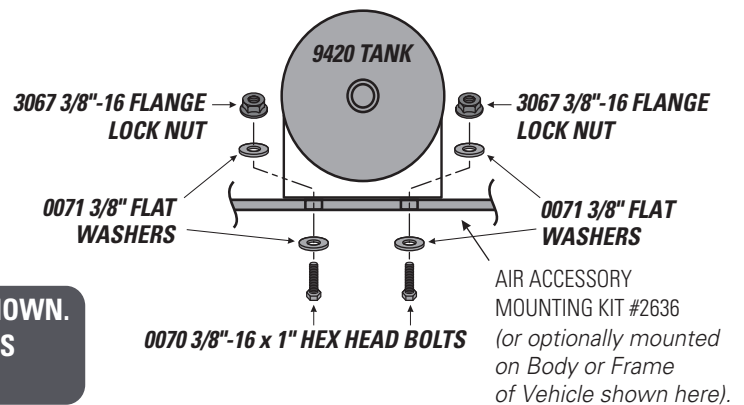

**OPTIONAL FRAME MOUNTING FOR TANK SHOWN. REFER TO MOUNTING KIT INSTRUCTIONS FOR PROVIDED TANK BRACKETS.**



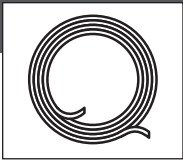

Use the route you selected during the Planning the Installation step on page 4.



EXHAUST ALL AIR FROM THE SYSTEM PRIOR TO RELEASING AIR TUBING FROM AIR FITTINGS.



THE AIR LOOPS CREATES A TRAP FOR CONDENSATION TO GATHER. WITHOUT THIS TRAP, THE AIR COMPRESSOR COULD BE DAMAGED BY WATER INTAKE.

- 1 Route the Air Tubing from the Air Tank to the Control Panel, leaving room to secure line safely. Use guidelines below to cut.
- 2 Install the Air Tubing into the Push-to-Connect fitting on the back of the Control Panel as shown.
- 3 Install the Air Tubing from the other end of the Air Tank into the 1/8 NPT Push-to-Connect Straight Fitting on the top of the Air Compressor.
- 4 Use supplied Nylon Ties to install the Air Filter in a dry, secure place, away from dirt and debris. Periodically check the Air Filter during operation, and replace it when it becomes dirty.

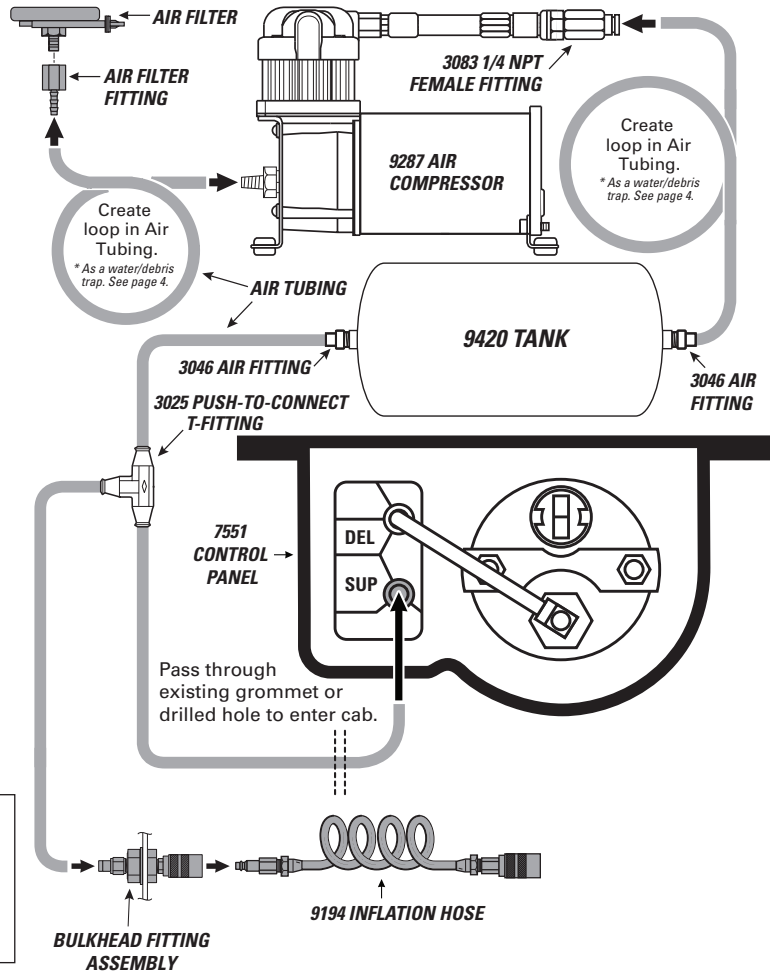

FOR PROPER INSTALLATION, SOAK AIR LINE TUBE ENDS IN HOT WATER BEFORE INSTALLING ONTO BARBED FITTINGS.

**DO**

Make sure the cut is as square as possible. Use a tube cutter or sharp utility knife.

**DON'T**

Fold or kink the Air Tubing. Cut the Air Tubing at an angle. Use pliers, scissors, snips, saws, or side cutters

PROPER AND IMPROPER CUTS IN THE AIR LINE TUBE

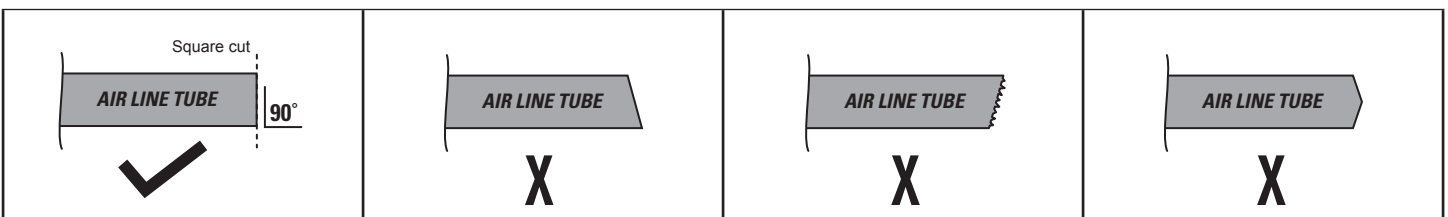

# 6

## INSTALL T-FITTING AND ROUTE AIR LINE TUBE TO CONTROL PANEL

Use the route you selected during the Planning the Installation step on page 4.

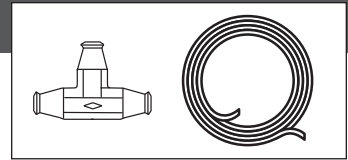

EXHAUST ALL AIR FROM THE SYSTEM PRIOR TO RELEASING AIR TUBING FROM AIR FITTINGS.



FOR PROPER INSTALLATION, SOAK AIR LINE TUBE ENDS IN HOT WATER BEFORE INSTALLING ONTO BARBED FITTINGS.

**1** Route the Air Tubing from the Control Panel to the Air Springs.

**2** Install the Air Tubing end onto the Barbed Fitting on the back of the Control Panel pressure gauge as shown.

**3** Determine a safe location for the Push-to-Connect T-fitting, where Air Tubing from the Air Springs and the Control Panel can safely meet.

**4** Install the Air Tubing from the Air Springs into opposite ends on the Push-to-Connect T-fitting, as shown.

**5** Install the Air Tubing from the Control Panel to the single end on the Push-to-Connect T-fitting.

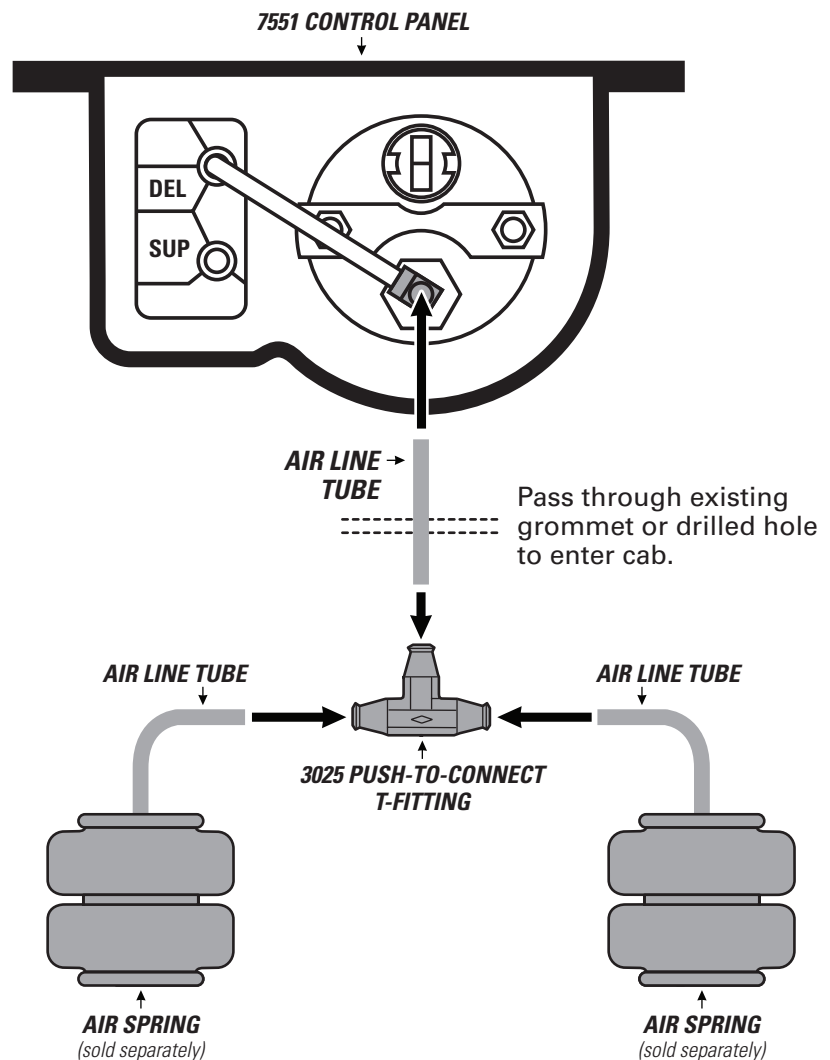

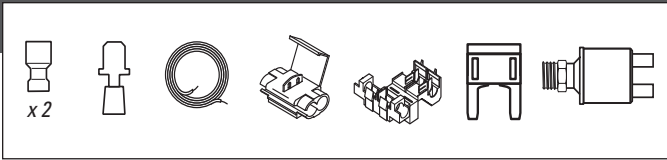

**1** Insert the Pressure Switch in the 1/8 NPT offset port on the Air Tank.

Cut a length of 16 Gauge Wire from the 15' included with this kit. Crimp a 16 Gauge Male Space Connector on one end to connect to the Female Spade Connector coming off of the Compressor. Crimp a Blue Female Spade Connector to the other end to connect to the Pressure Switch.

**2** Using another piece of wire, install another Blue Female Space Connector to one end for the other spade terminal on the Pressure Switch. Connect the other end of the wire to a 12 Volt power wire with a Wire Connector. The 12 Volt power wire should be connected to an ignition powered source.

**3** Install the In-Line Fuse Holder in the positive Pressure Switch Wire. Cut the Pressure Switch Wire and insert the unstripped ends of the wire into the Fuse Holder. Close the Fuse Holder over the wires with pliers and install the 30 Amp blade fuse.

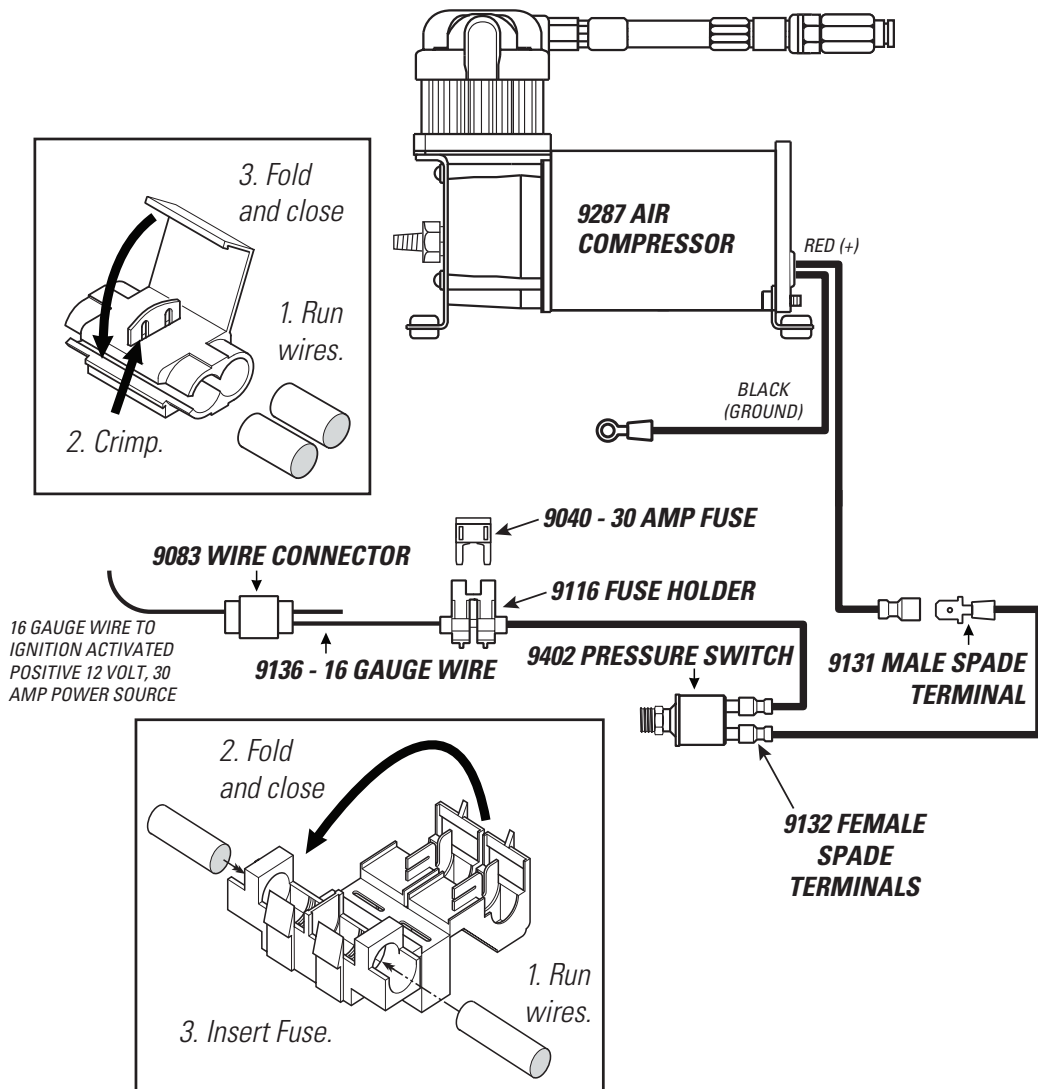

# 8

## FINISH WIRING AND INSTALLATION

\* Additional Male and Female 18 Gauge Spade Connectors provided if desired to create disconnects for control panel.

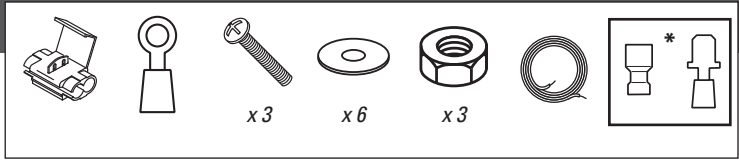

**1** Install Ring Terminal and Wire Connector as shown below on backlight wires. Use additional 18 Gauge Wire as needed.

**2** Fasten Control Panel backlight ground wire to vehicle as shown.

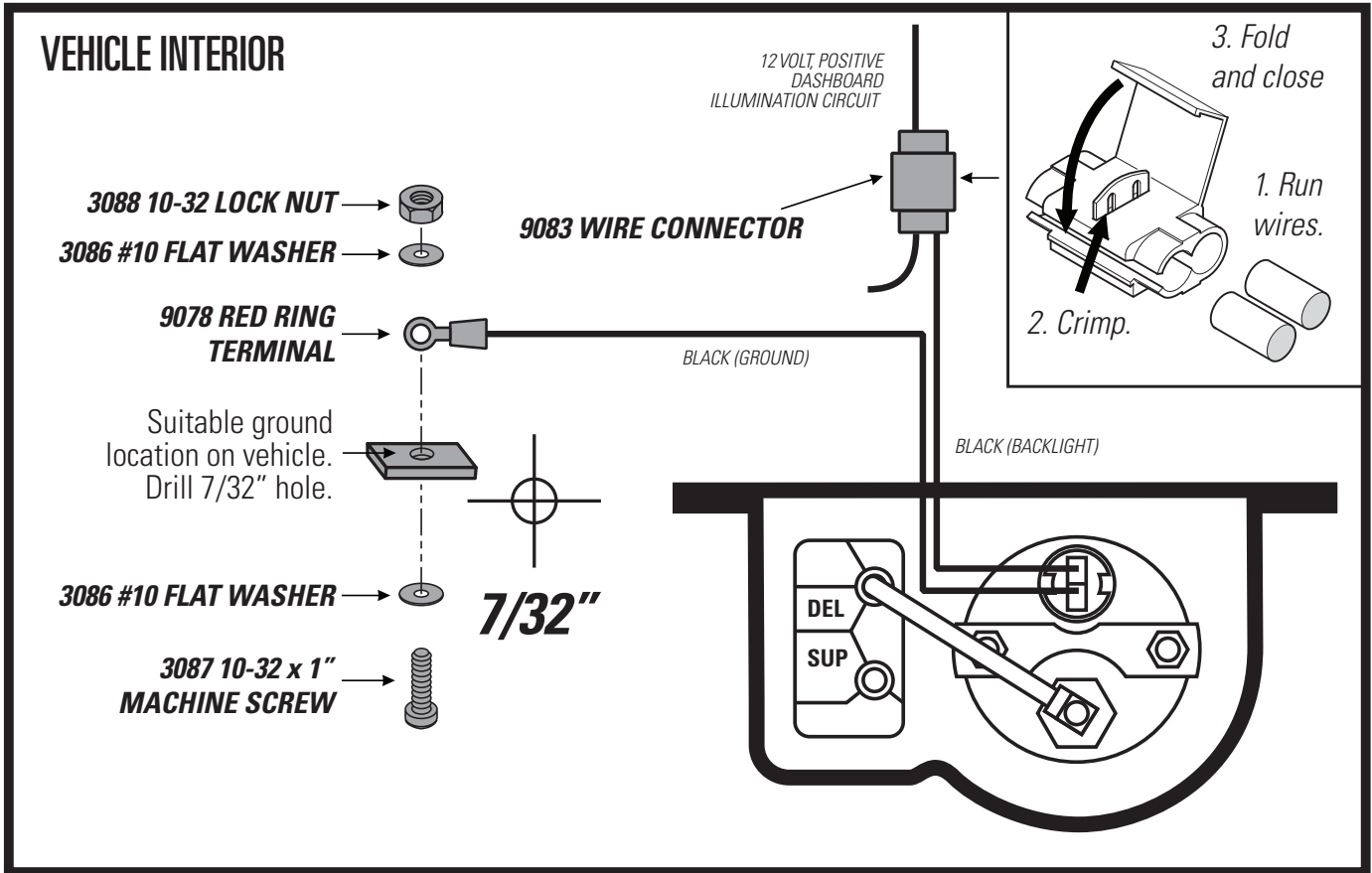

**3** Install the control panel using the supplied fasteners.

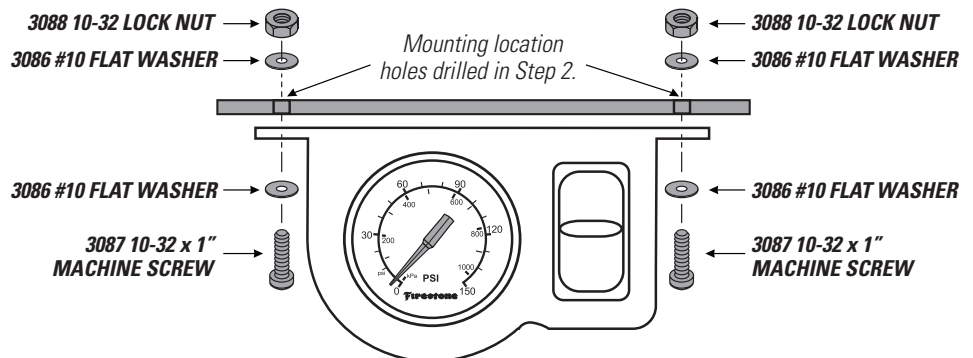

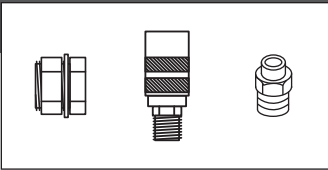

**1** Determine a suitable location to mount the Bulkhead Assembly and Fittings. This area should be convenient to access and safe from debris. Make sure you have room to attach the Inflation Hose.

**2** Drill a 3/4" hole in the selected mounting location and install the Bulkhead Assembly Components, Air Fitting and Dry Coupler Fitting, as shown.

**3** Install Air Tubing from the Push-to-Connect T-fitting between the Air Tank and the ECU to the Air Fitting installed into the Bulkhead Assembly.

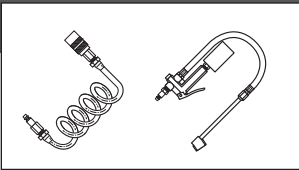
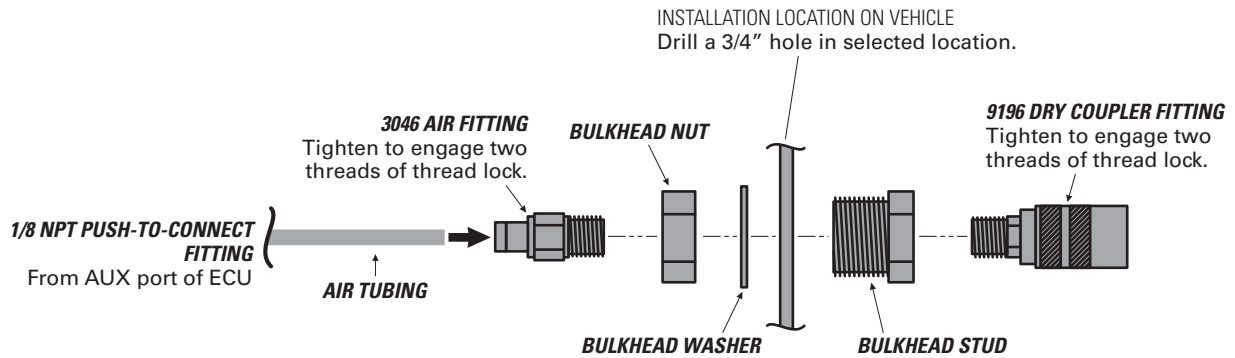

Connect the male Air Fittings to the Dry Couplers to use the Inflation Hose and Inflator. When finished, simply disconnect and store in the supplied Firestone Storage Bag.

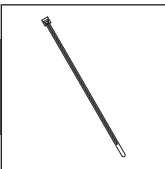
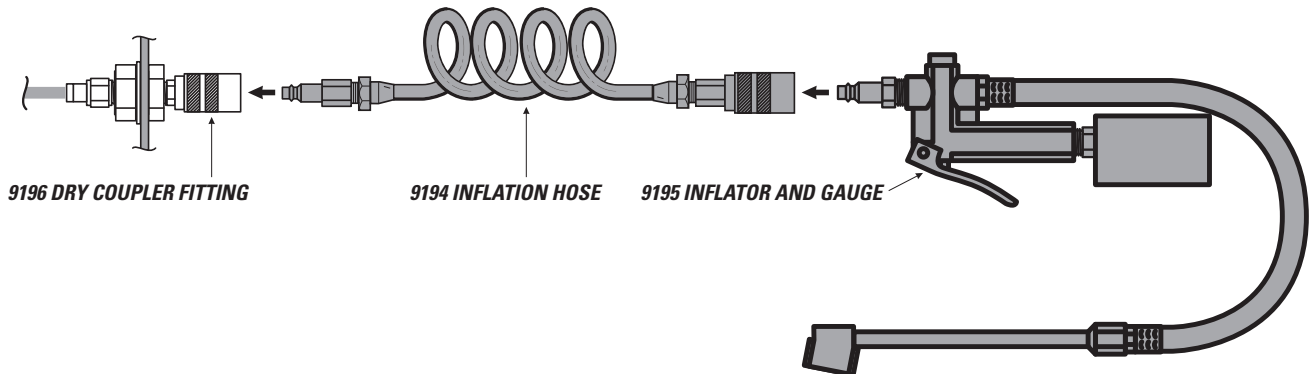

**1** Clean up the installation using supplied Nylon Ties, and return all factory parts and materials to operative state.

USING SUPPLIED NYLON TIES, SECURE ALL WIRING AND AIR TUBING IN A MANNER THAT DOES NOT OBSTRUCT MOVING PARTS OR IN ANY WAY THAT AFFECTS YOUR ABILITY TO SAFELY OPERATE THE VEHICLE.



# 12

## TEST THE SYSTEM

With the Air Command™ kit and your air springs installed, you are ready to test the system.

- 1 Reattach the negative battery cable.

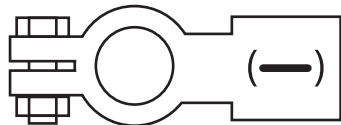

- 2 Turn on your vehicle's ignition.

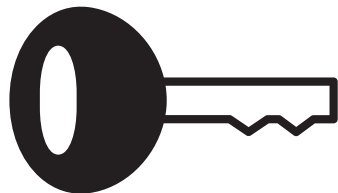

- 3 Push paddle switch up to inflate the Air Springs to 70 PSI.

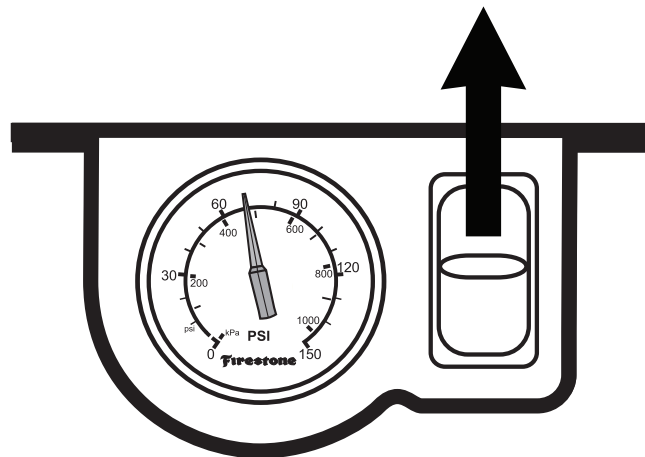

- 4 Spray fittings with soap and water mixture.



- 5 Observe bubbles.

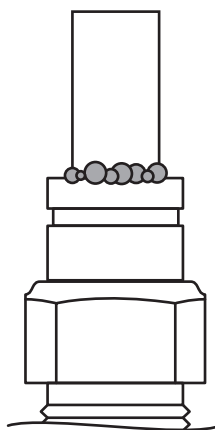

**SMALL SOAP BUBBLES THAT DO NOT EXPAND**

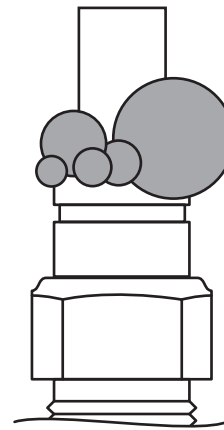

**SOAP BUBBLES THAT EXPAND**



# NO LEAKS?

Congratulations! You're riding right with the flip of a switch! Remember to review the Operating Instructions.

# LEAK?

Bummer. Continue to step 12 to fix the leak.



EXHAUST ALL AIR FROM THE SYSTEM PRIOR TO RELEASING AIR TUBING FROM AIR FITTINGS.



**1** Push paddle switch down to release all air pressure from the Air Springs.

NOTE: While doing this, if you get a quick burst of air prior to the gauge dropping to 0 PSI, your lines are incorrectly swapped.

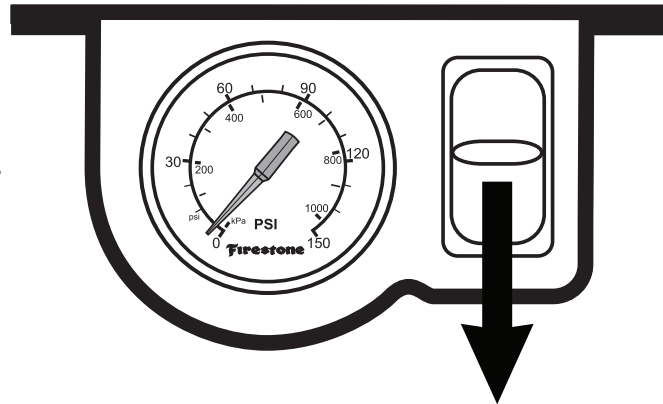

#### LEAK AT AIR LINE TUBE AND AIR FITTING

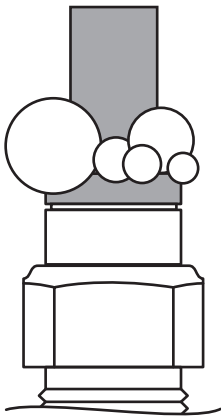

Release air line tube (see page 4). Review proper cuts and procedures in step 5. Repeat installation steps.

#### LEAK AT BASE OF AIR FITTING ON AIR SPRING

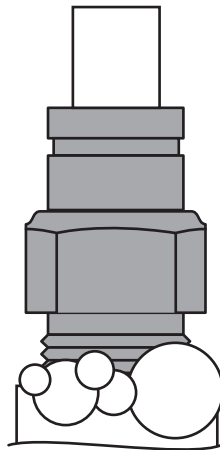

Tighten air fitting one turn or until leak stops.

#### LEAK AT A BARBED FITTING

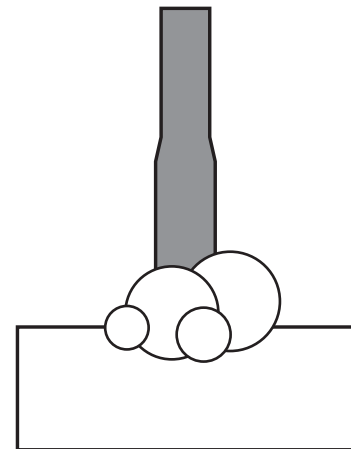

Being careful not to scar the metal barbs, cut away, check for debris. Trim air tube line, **soak for 5 minutes in hot water**. Reinstall.

## STILL HAVE A LEAK?

Refer to the Troubleshooting section of the Instruction Manual. If the leak persists, or if there is an issue with a leaking part, email us at [rrtech@fsip.com](mailto:rrtech@fsip.com). If emailing, please include photos to help us better diagnose and understand any problems you may be experiencing.



# AIRIDE

[firestoneairide.com](http://firestoneairide.com)

## BEFORE YOU DRIVE, CONFIRM THE FOLLOWING:

- Secure all air line tubes and wiring inside the cab and on the outside of the truck.
- Make sure no wiring, air line tubes, or hardware obstruct your vision or ability to safely operate the vehicle.
- The system passes the leak test and holds air.
- The air compressor ground ring terminal is contacting bare metal, and coated with silicone if possible.
- There is a loop in the air line tubes as shown to prevent water or debris from getting into the air compressor head and damaging it.
- The air gauge backlight turns off when the ignition is off, or when dashboard lights do not illuminate.
- Put a minimum of 5 PSI in the air springs, unloaded.

## NEED INSTALLATION HELP?

Email us at [rrtech@fsip.com](mailto:rrtech@fsip.com). Please include photos, kit number, and the year, make, and model of the vehicle to help us better diagnose and understand any problems you may be experiencing.

CONNECT WITH US



@firestoneairide



FirestoneAiride



Firestone Airide





**AIRIDE**

[firestoneairide.com](http://firestoneairide.com)

# INSTALLATION INSTRUCTIONS

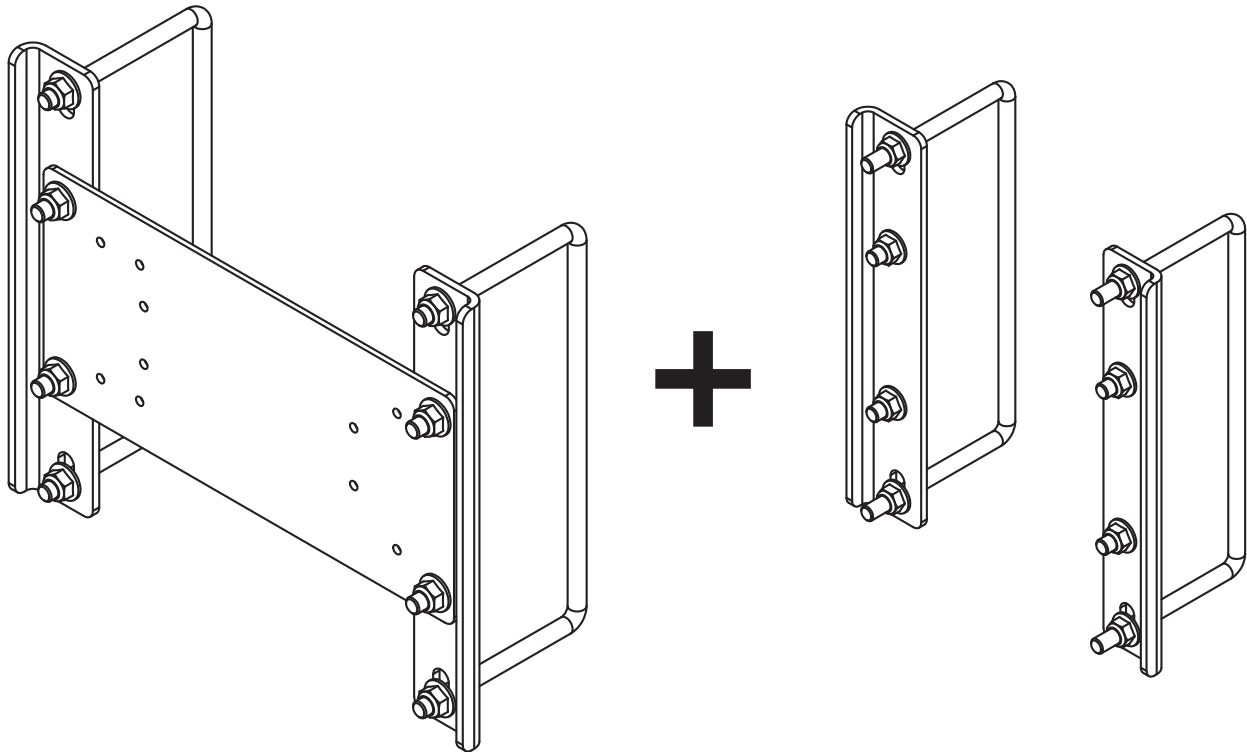

# ! IMPORTANT

PLEASE DON'T HURT YOURSELF, YOUR KIT OR YOUR VEHICLE. TAKE A MINUTE TO READ THIS IMPORTANT INFORMATION.

DO NOT INSTALL IF THE TRUCK HAS BEEN LIFTED AND THE STOCK JOUNCE BUMPER SPACERS ARE NOT ON THE VEHICLE. *This kit is to be used on a pickup truck only, and DOES NOT INCREASE YOUR VEHICLE'S MAXIMUM LOAD.*

## SAFE INSTALLATION

Please take all safety precautions during installation. A hydraulic jack can fail, and if that happens, you can be seriously hurt, or worse, if you are relying on it to hold up the vehicle. If you use a hydraulic jack, secure jack stands in the appropriate locations and chock any tires still touching the ground.

Wear safety glasses or goggles. Your eyes may be lower than some parts and pieces, and you don't want to lose an eye.

Remove the possibility of any electrical issues by disconnecting the negative battery cable.

## KIT USES

This kit works with Air Command Kits 2902 and 2912. Refer to the following pages for kit-specific layouts to ensure proper fitment.

## VEHICLE GVWR

NEVER exceed the maximum load recommended by the vehicle manufacturer (GVWR). The GVWR can be found in your vehicle's owner's manual or on the data plate on the driver's side door.

## INFLATING THE AIR SPRINGS

When inflating air springs, add air pressure in small quantities, checking air pressure frequently. The air springs have much less air volume than a tire, so they inflate much more quickly.



## APPROPRIATE AIR PRESSURE

For best ride, use only enough air pressure in the air springs to level the vehicle when viewed from the side (front to rear). This will vary, depending on the load, location of the load, condition of the existing suspension, and personal preference.

# PARTS

Compare the parts below to your kit. Ensure you have all pieces, and organize them for an easier installation.

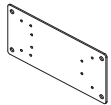
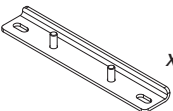
## MAIN KIT CONTENTS

PT # 5970	 x 1	COMPRESSOR MOUNTING PLATE	PT # 5705	 x 4	AIR ACCESSORY FRAME BRACKET	PT # 3414	 x 4	BAIL CLAMP
-----------	---	---------------------------	-----------	---	-----------------------------	-----------	---	------------

## A21-760-2530 HARDWARE PACK

PT # 3067	 x 16	3/8"-16 HEX HEAD FLANGE NYLOCK NUT
-----------	--	------------------------------------

**1** Secure the Compressor Mounting Plate to the System Frame Brackets shown below.

**2** Select a suitable location for installation on the vehicle frame rail.

It is recommended to mount to the passenger side frame rail as the vehicle's battery is normally located in the engine compartment on the passenger side. Double check fitment for obstructions before final installation.

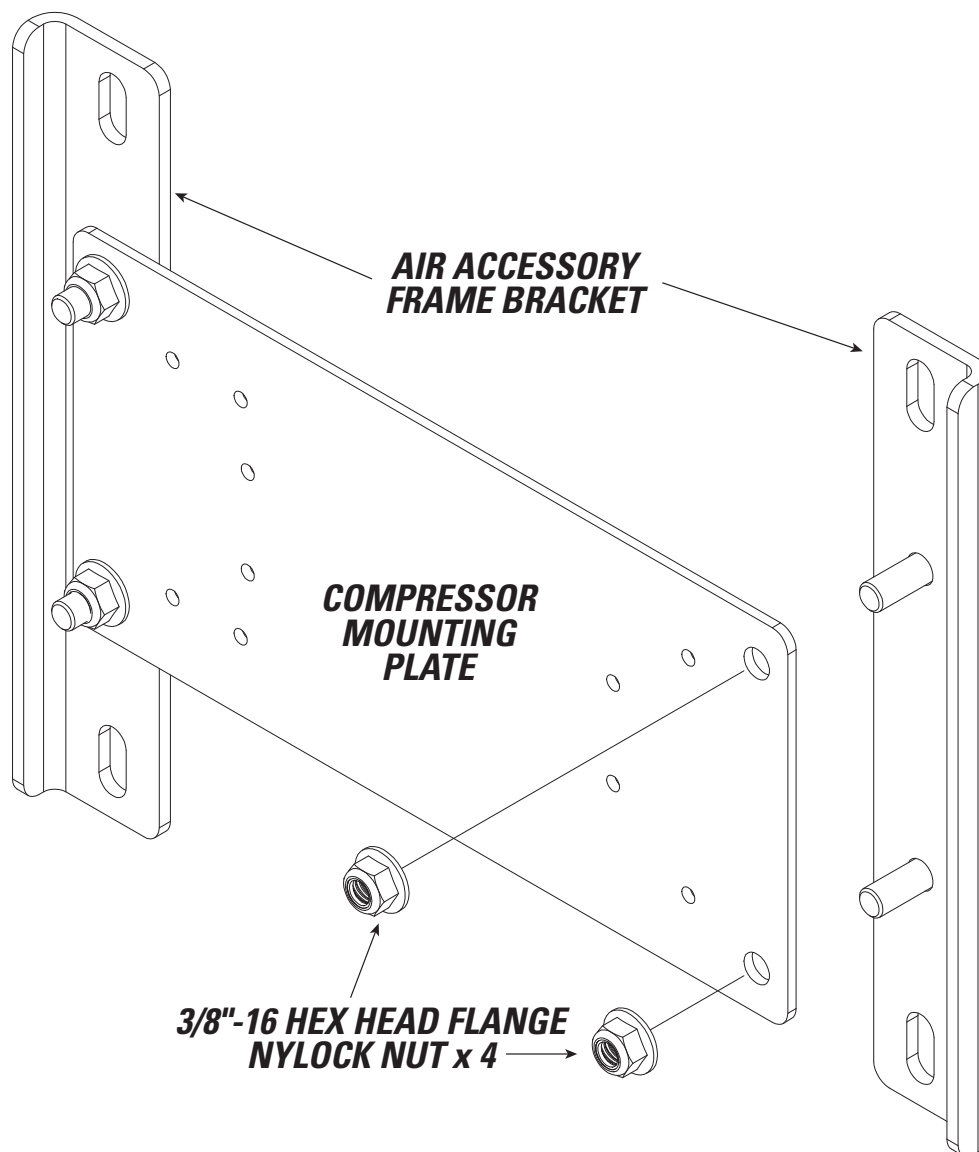

# 2

## INSTALL THE AIR COMPRESSOR - USE FOR STANDARD DUTY AIR COMMAND KITS 2902 & 2912

Fasteners included in Air Command Kit

x 4      x 8      x 4



DO NOT OVER TIGHTEN MOUNTING BOLTS AND NUTS ON THE AIR COMPRESSOR. TOO MUCH TORQUE CAN CRUSH THE BRASS INSERTS AND RUBBER ISOLATORS.

**1** Mount the Air Compressor to the hole locations in the Compressor Plate using the supplied fasteners. DO NOT OVERTIGHTEN.

**2** It is recommended to face the outlet of the compressor towards the air springs on the rear axle of vehicle.

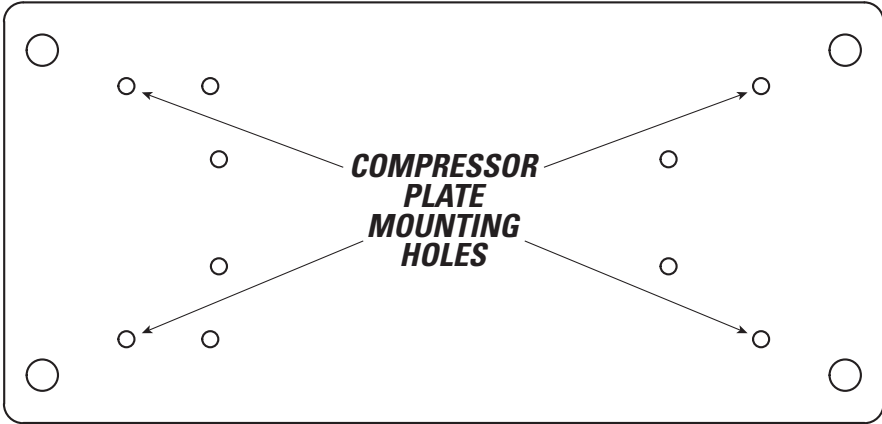
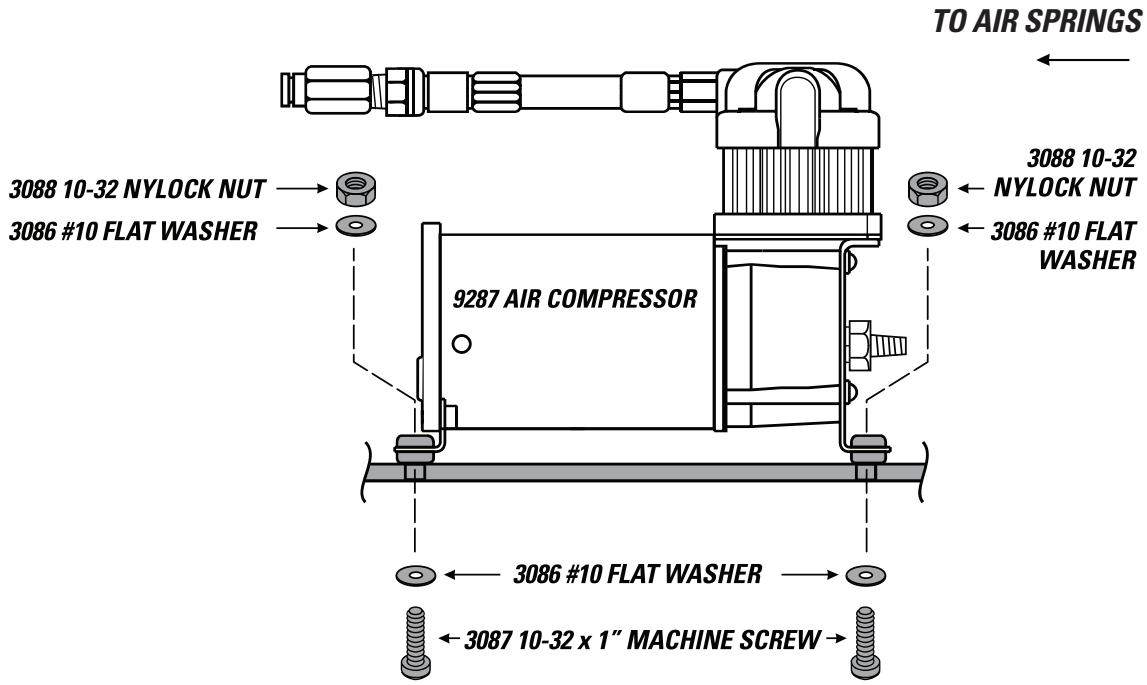



AIR ACCESSORY MOUNTING KIT CANNOT BE USED AS A GROUNDING LOCATION FOR THE AIR COMPRESSOR

**1** Install the compressor mounting assembly to the vehicle's frame rail, using the provided Bail Clamps.

### RECOMMENDED

**2** Continue following the Air Command Kit instructions to connect all air tubing and electrical wiring.

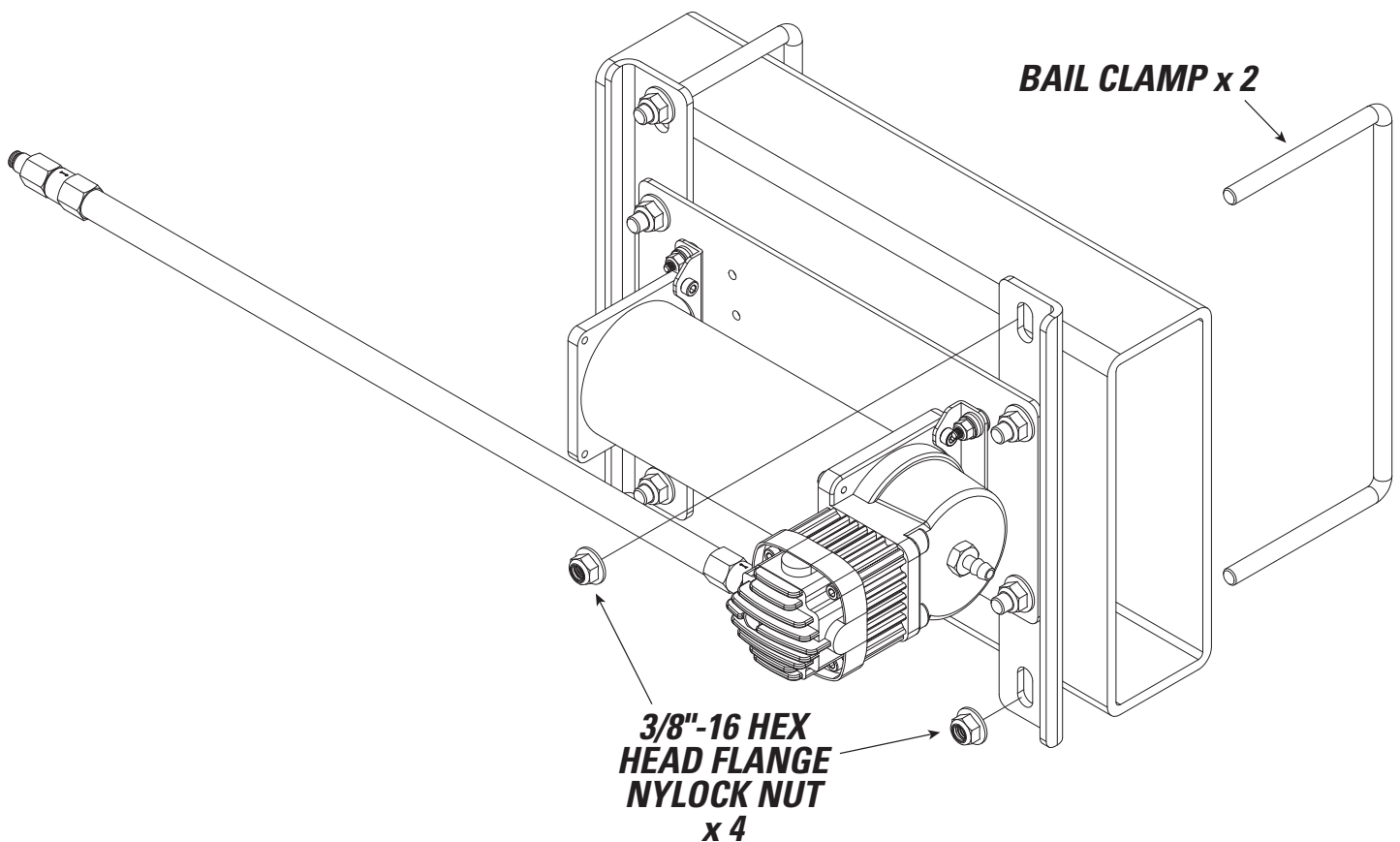

- 1** Mount the Air Accessory System Frame Bracket to the feet of the Air Tank.

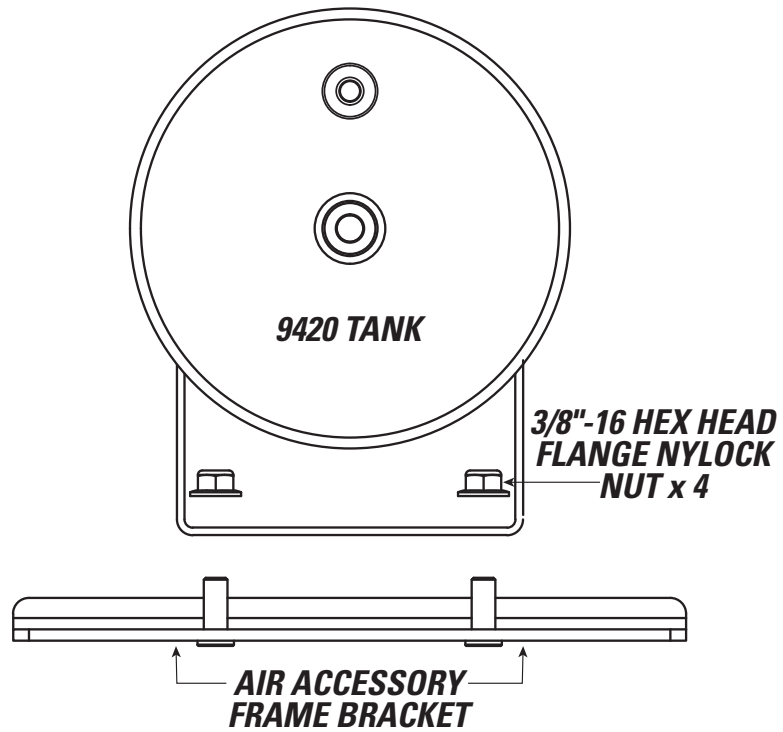

- 2** Determine a location on the frame rail of the vehicle to mount the tank. This should be as close to the Air Compressor as possible.

- 3** Mount tank and brackets to the frame rails with the provided bail clamps.

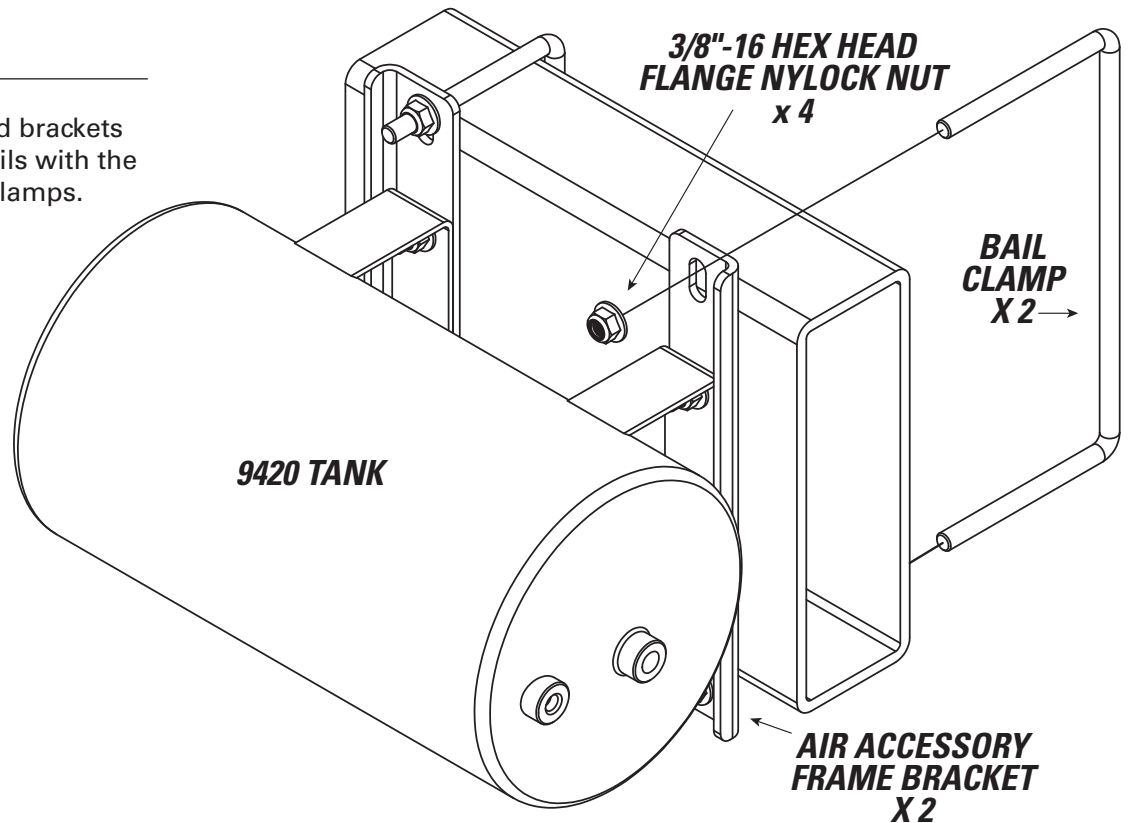

# NOTES

---

---

---

---

---

---

---

---

---

---

---

---

---

---

---

---

---

---

---

---

---

---

---

---



# AIRIDE

[firestoneairide.com](http://firestoneairide.com)

## BEFORE YOU DRIVE, CONFIRM THE FOLLOWING:

- Make sure all fasteners are tight and secure.
- Make sure the installation does not interfere with any other components on the vehicle.
- Reattach negative battery cable.

## NEED INSTALLATION HELP?

Email us at [rrtech@fsip.com](mailto:rrtech@fsip.com). Please include photos, kit number, and the year, make, and model of the vehicle to help us better diagnose and understand any problems you may be experiencing.

CONNECT WITH US



@firestoneairide



FirestoneAiride



Firestone Airide