

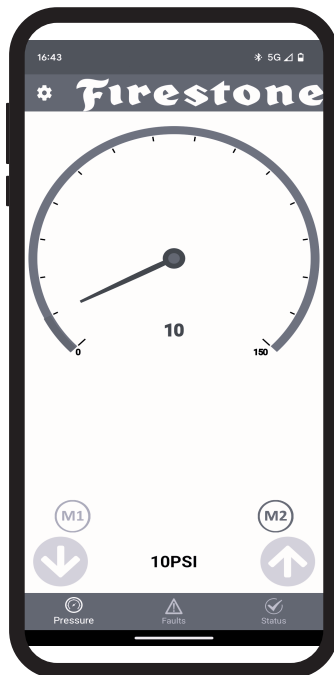

# AIRIDE

firestoneairide.com

# INSTALLATION INSTRUCTIONS

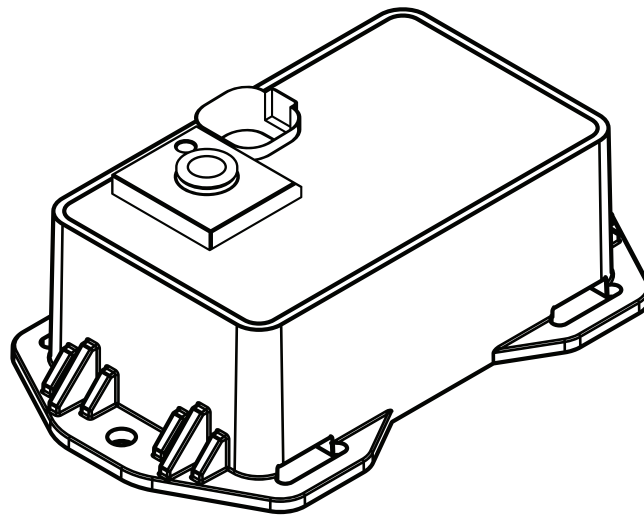

# **IMPORTANT**

*PLEASE DON'T HURT YOURSELF, THE KIT, OR YOUR VEHICLE. TAKE A MINUTE TO READ THIS IMPORTANT INFORMATION.*

## **SAFE INSTALLATION**

Please take all safety precautions during installation. A hydraulic jack can fail, and if that happens, you can be seriously hurt, or worse, if you are relying on it to hold up the vehicle. If you use a hydraulic jack, secure jack stands in the appropriate locations and chock any tires still touching the ground.

Wear safety glasses or goggles. Your eyes may be lower than some parts and pieces, and you don't want to lose an eye.

Remove the possibility of any electrical issues by disconnecting the negative battery cable.

## **VEHICLE GVWR**

NEVER exceed the maximum load recommended by the vehicle manufacturer (GVWR). The GVWR can be found in your vehicle's owner's manual or on the data plate on the driver's side door. Consult your local dealership for additional GVWR specifications.

## **PRESSURE TO LOAD**

Be sure to review the load limits noted in the Air Spring Kit Installation Instructions (sold separately).

## **APPROPRIATE AIR PRESSURE**

For best ride, use only enough air pressure in the Air Springs to level the vehicle when viewed from the side (front to rear). This will vary, depending on the load, location of the load, condition of the existing suspension, and personal preference.

**ONCE INSTALLED SUCCESSFULLY, FOLLOW THE PRESSURE REQUIREMENTS FOR THE AIR SPRINGS.  
FOR FIRESTONE, GENERALLY:**

### **COIL-RITE**



### **RIDE-RITE**



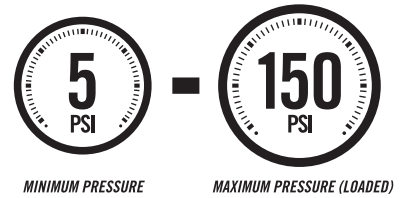

### **RED LABEL**



# PARTS

Compare the parts below to your kit. Assure you have all pieces, and organize them for an easier installation.

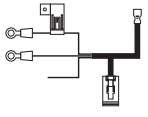
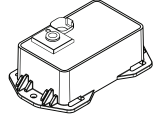
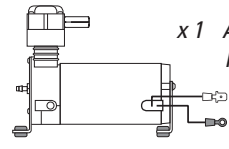









## MAIN KIT CONTENTS

PT # 9534	 x1 WIRE HARNESS	PT # 9535	 x1 ECU	PT # 9499	 x1 AIR COMPRESSOR KIT
				PT # 9414	 x1 AIR LINE TUBE (18 FEET)

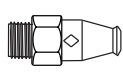
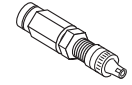
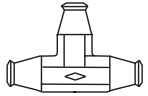
## A24-760-2642 COMPRESSOR AND ECU MOUNTING KIT

KIT # 2642	 x1 SINGLE PATH MOUNTING KIT <i>The parts list for this kit is in the Mounting Kit Manual included at the end of this Manual.</i>
------------	---

## A21-760-2921 HARDWARE PACK

PT # 3087	 x4 10-32 x 1" MACHINE SCREW	PT # 3093	 x2 10-32 x 3/4" MACHINE SCREW	PT # 3086	 x10 #10 FLAT WASHER
PT # 3088	 x6 10-32 NYLOCK NUT	PT # 3055	 x1 1/8 NPT PUSH-TO-CONNECT STRAIGHT FITTING	PT # 3032	 x1 INFLATION VALVE AND VALVE CAP ASSEMBLY
PT # 3025	 x3 1/4" PUSH-TO-CONNECT TEE	PT # 3421	 x1 10-16 x 3/4" SELF-TAPPING SCREW	PT # 9036	 x8 RED NYLON TIE
PT # 9488	 x4 LARGE NYLON TIE	PT # 0899	 x2 THERMAL SLEEVE	PT # 9483	 x1 NO-DRILL INFLATION VALVE BRACKET

# CONTENTS AND OVERVIEW

- PAGE **4** **PLANNING THE INSTALL**

---

- PAGE **5** **PREPARE THE AIR COMPRESSOR**

---

- PAGE **6** **DRILL HOLES FOR AIR COMPRESSOR AND ECU**

---

- PAGE **7** **INSTALL THE AIR COMPRESSOR AND ECU**

---

- PAGE **8** **INSTALL THE WIRE HARNESS**

---

- PAGE **9** **INSTALL THE AIR LINE TUBES**

---

- PAGE **10** **OPTIONAL INFLATION VALVE INSTALLATION**

---

- PAGE **11** **INSTALL THE AIR FILTER AND CLEAN UP**

---

- PAGE **12** **CONNECTING TO THE APP**

---

- PAGE **13** **TEST THE SYSTEM**

---

- PAGE **14** **FIX AN AIR LEAK**

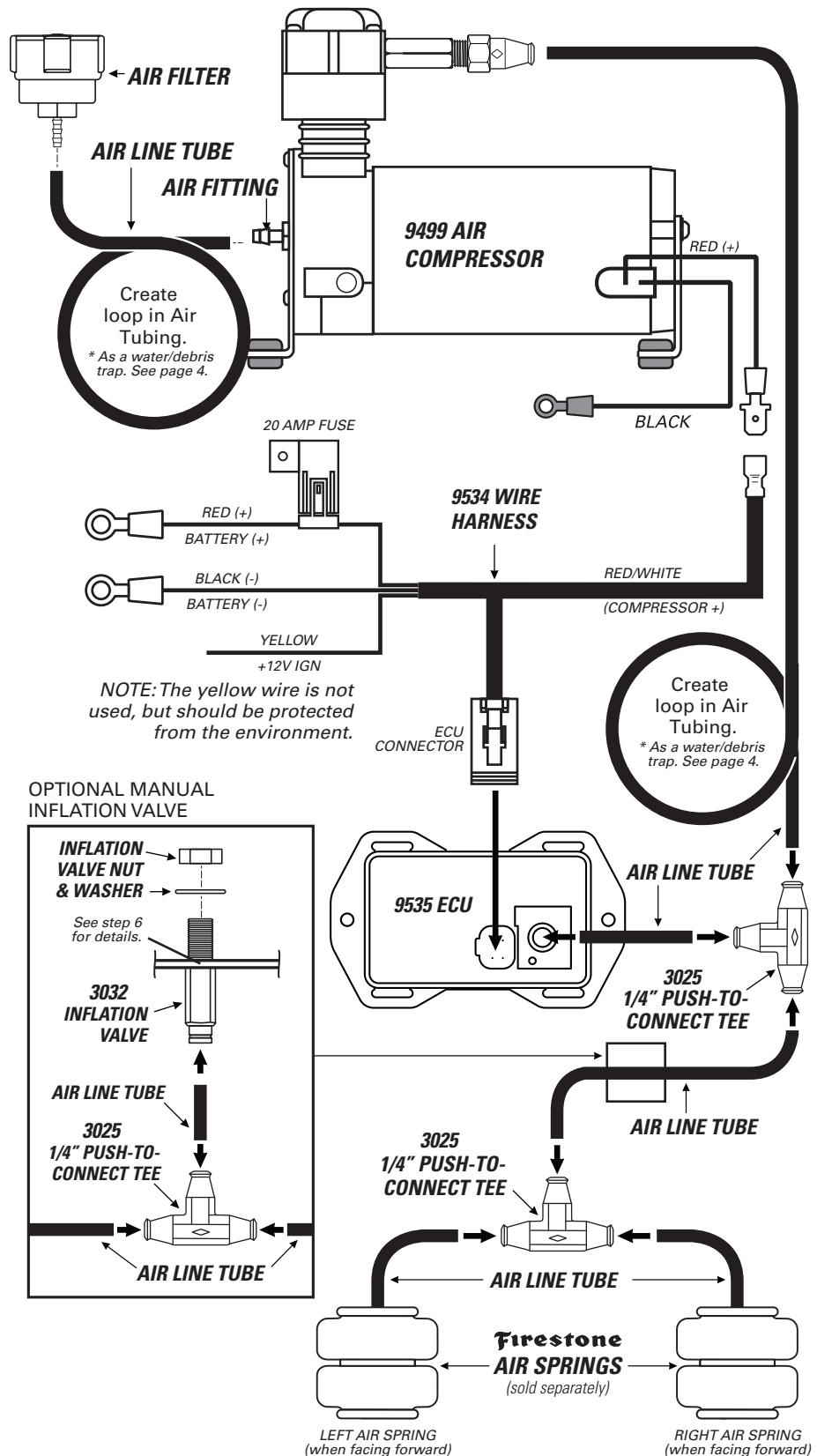

# PLANNING THE INSTALL

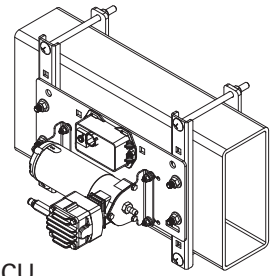

THESE PLANNING STEPS WILL HELP YOU SAVE TIME AND WILL MAKE THE INSTALLATION EASIER.

## **DETERMINE THE MOUNTING LOCATION FOR THE AIR COMMAND KIT**

- This Kit comes with a Mounting designed specifically for the provided Air Compressor and ECU.
- Refer to the Mounting Kit Manual attached at the end of this Kit's Manual for additional instructions.
- Consult the **OPTIONAL** instructions below and in Section 2 only if the Mounting Kit does **NOT** fit your vehicle.

## **PLAN INSTALLATION ROUTES FOR WIRING AND AIR LINES**

- Make sure the Wire Harness and Air Tubing are not exposed to sharp metal edges that can damage them.
- Use supplied Thermal Sleeves on Air Tubing when routing near heat sources.
- Use supplied Nylon Ties to secure Air Tubing and Wire Harness to the vehicle.
- Make a loop in the Air Tubing where shown. This creates a water/debris trap that protects the Air Compressor.
- Measure twice, cut once!

## **TAPE ALL ELECTRICAL CONNECTIONS**

- Use electrical tape to appropriately secure and protect all electrical connections.

## **USING PUSH-TO-CONNECT FITTINGS FOR AIR LINES**

Your kit includes Push-to-Connect fittings to connect the Air Tubing to hardware. Use the instructions below when using the Air Tubing.

- 1** Insert end of Air Tubing into Air Fitting.

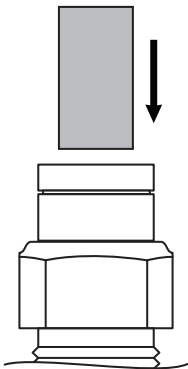

- 2** Push Air Tubing into Air Fitting as far as possible.

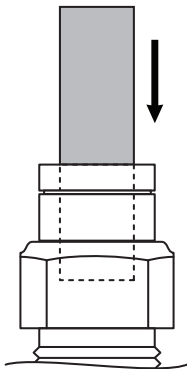

- 3** Gently pull on the Air Tubing to check for a secure fit.

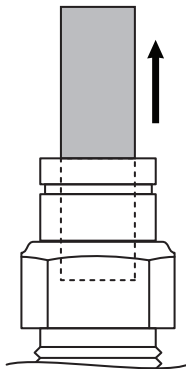

- 4** To remove, push down collar and gently pull Air Tubing away.

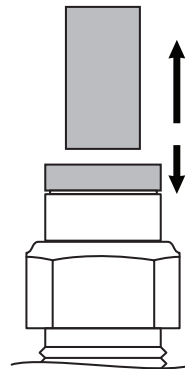

**Removal Tip:** Use a 1/4", 5/16", or 6mm open-ended wrench to push the collar down.

## **OPTIONAL**

### **DETERMINE THE MOUNTING LOCATION FOR THE AIR COMPRESSOR AND ECU**

- Mount in a location protected from airborne debris and moisture.
- Allow room for the Air Tubing to run without sharp curves or bends.
- Allow room for the Tubing to connect to the Air Fitting on the ECU.
- Allow room for the 4-pin ECU connector to connect to the ECU.
- Mount close enough together to allow Wire Harness connections to reach the Air Compressor and ECU.
- Using supplied fasteners shown in Step 3 is recommended. If no other mounting option is available, see the sidebar on Step 2 for using the Large Nylon Ties.
- Select a location that is solid and secure on the body or frame of the vehicle, away from any moving parts, electrical or any other lines.

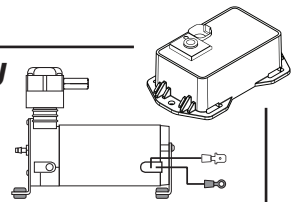

# 1

## PREPARE THE AIR COMPRESSOR

*NOTE: Air Compressor can be mounted facing any direction.*

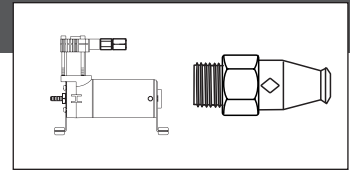

**1** Install 1/8 NPT Push-to-Connect Straight Fitting on the Check Valve.

**2** Install Barbed Air Fitting in Inlet Port of the Compressor from Air Compressor Kit.

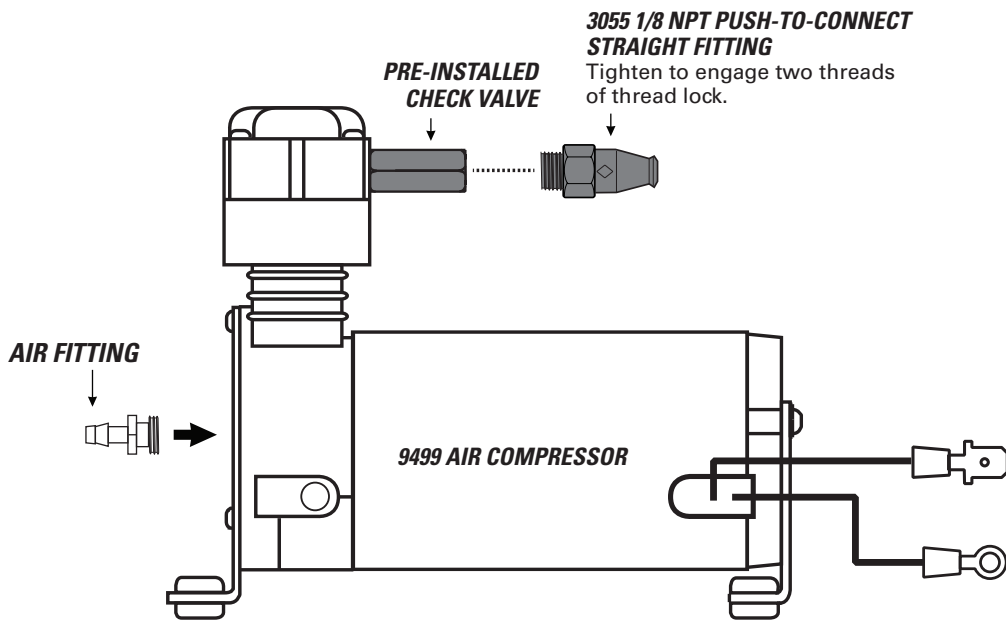

# OPTIONAL - DRILL HOLES FOR AIR COMPRESSOR AND ECU

2

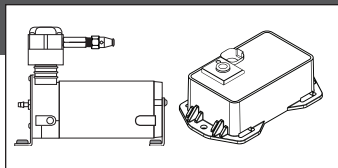

IF YOU ARE USING THE SUPPLIED FIRESTONE AIR ACCESSORY MOUNTING KIT, SKIP THIS STEP AND REFER TO THE MOUNTING KIT'S INSTRUCTIONS AT THE END OF THIS MANUAL.

## STOP HERE AND SKIP THIS STEP IF USING THE PROVIDED MOUNTING KIT



CHECK SURROUNDING AREA AND BACK SIDE OF MOUNTING LOCATION TO AVOID DRILLING INTO EXISTING LINES OR WIRING.

Drill within reach of the ground wire ring terminal on body or frame of vehicle or create a wire to link to the negative battery terminal. Minimum gauge of wire should be 12.

**AIR ACCESSORY MOUNTING KIT CANNOT BE USED AS A GROUNDING LOCATION FOR THE AIR COMPRESSOR.**

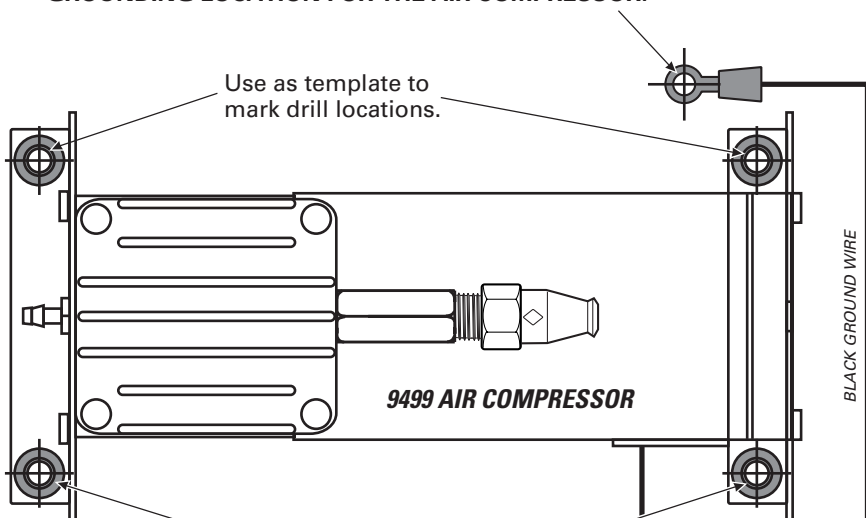

**1** Using the Air Compressor and ECU as templates, mark drill locations as shown with a punch or marking tool.

**2** Mark Air Compressor ground wire fastening location within reach of the ground wire ring terminal.

**3** Drill 7/32" diameter holes. Remove any burrs and debris from drill holes.



ASSURE THAT YOU INSTALL THE AIR COMPRESSOR AND ECU CLOSE ENOUGH SO THE CONNECTORS ON THE WIRE HARNESS WILL REACH THEM BOTH.

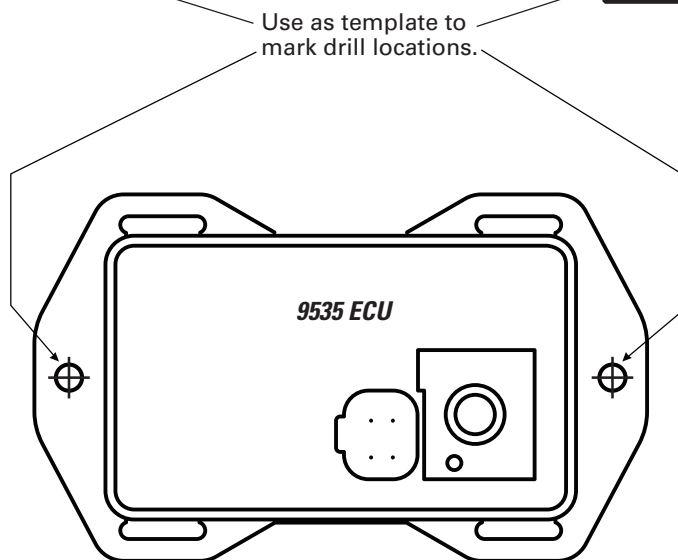

### OPTIONAL ECU MOUNTING

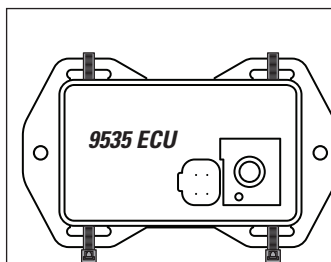

If there is no other mounting option, use two Large Nylon Ties to secure ECU to the location determined in planning the install section. Route the Nylon Ties under the ECU and around the mounting location.

# 3

## INSTALL THE AIR COMPRESSOR AND ECU

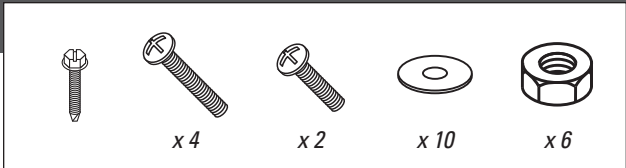

DO NOT OVER TIGHTEN MOUNTING BOLTS AND NUTS ON THE AIR COMPRESSOR. TOO MUCH TORQUE CAN CRUSH THE BRASS INSERTS AND RUBBER ISOLATORS.

**1** Mount the Air Compressor to the hole locations on the provided Mounting Kit using the supplied fasteners. DO NOT OVERTIGHTEN.

**2** Mount the ECU to the hole locations on the provided Mounting Kit using the supplied fasteners.

**3** Mount the black ground wire ring terminal using the supplied fasteners. Assure that the ring terminal makes a solid contact with bare metal for a proper ground.

### OPTIONAL

Mount to the drill holes made in the frame. Do this only if the mounting kit will not mount to the frame of the vehicle.

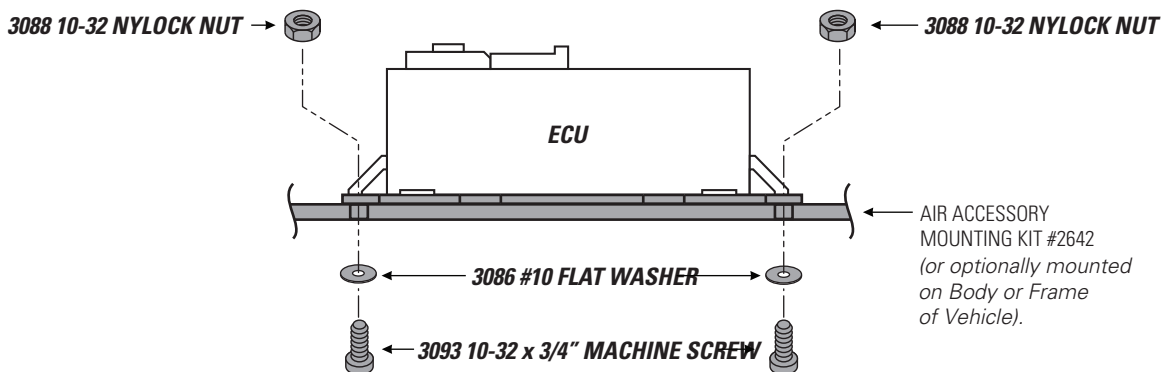
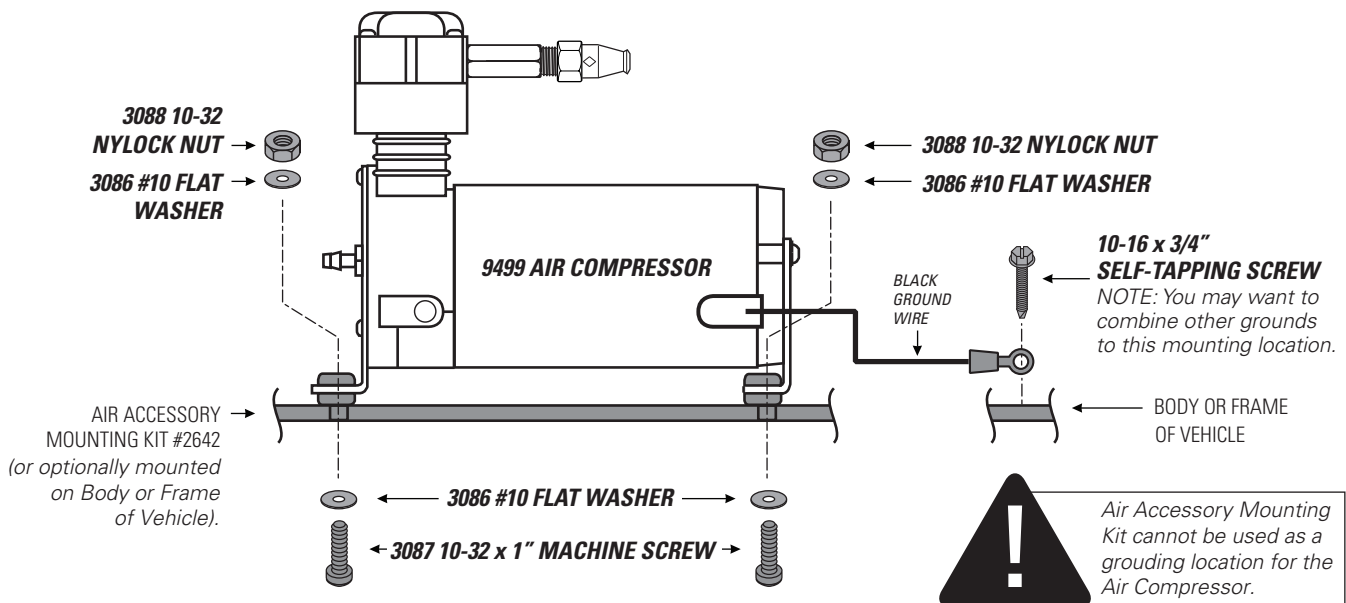



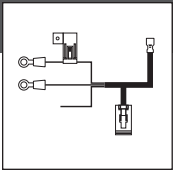

**1** Route the Wire Harness in the most protected manner possible, and securely make all connections as shown.

**2** The yellow wire is not used. Wrap or wire nut it to protect it from the environment.

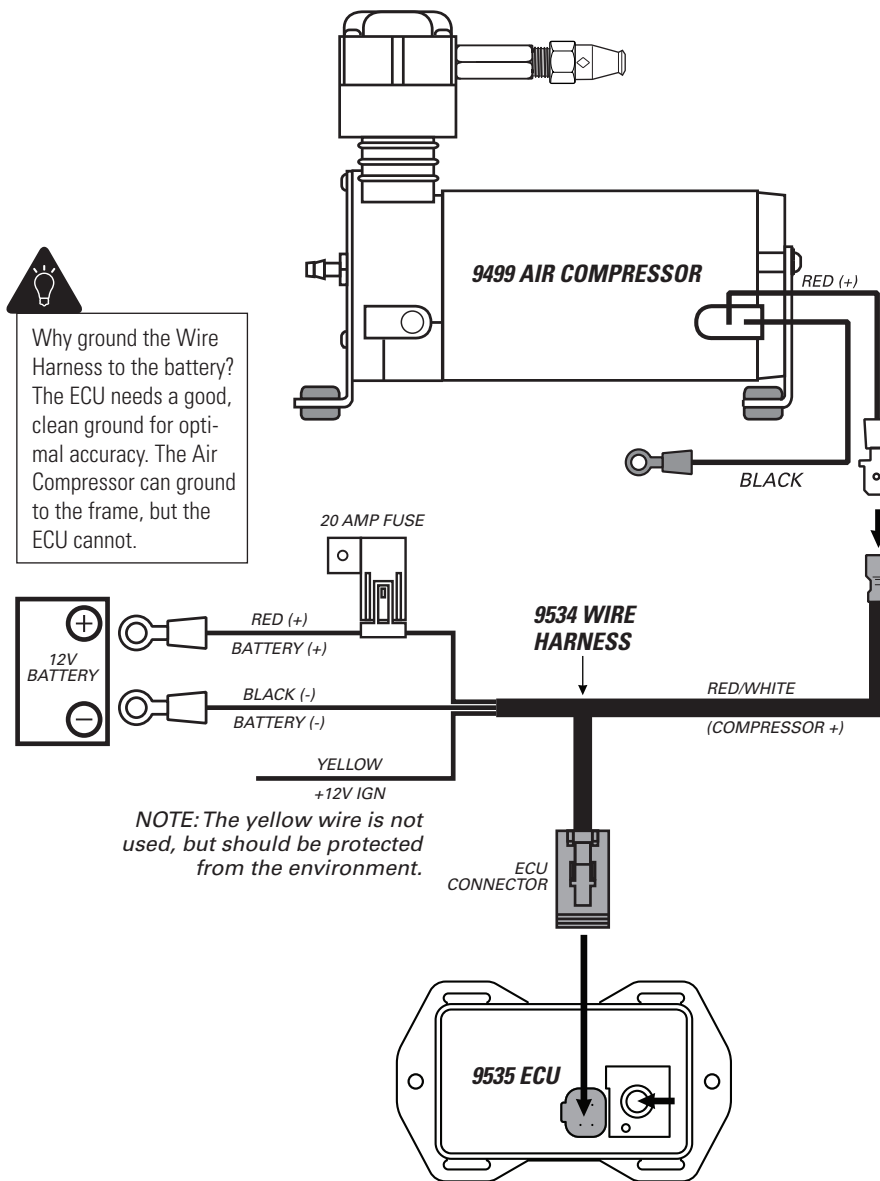

# 5

## INSTALL AIR LINE TUBES



EXHAUST ALL AIR FROM THE SYSTEM PRIOR TO RELEASING AIR TUBES FROM AIR FITTINGS.

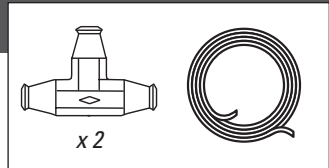

**1** Route the Air Tubing from 1/8 NPT Push-to-Connect Straight Fitting on the top of the Air Compressor to the first 1/4" Push-to-Connect Tee.

**2** From the 1/4" Push-to-Connect Tee, route Air Tubing to the ECU, as shown.

**3** Route Air Tubing from each Air Spring and connect to a 1/4" Push-to-Connect Tee, as shown.

**4** Route Air Tubing to connect the two 1/4" Push-to-Connect Tees, as shown.

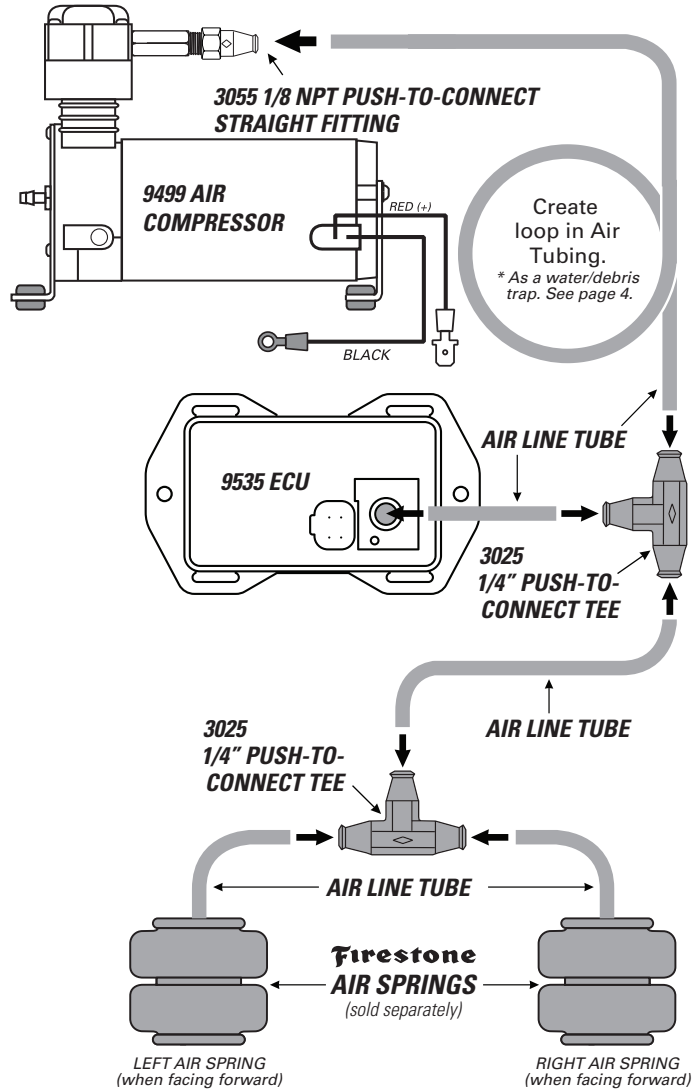

# DO

Make sure the cut is as square as possible. Use a tube cutter or very sharp utility knife.

# DON'T

Fold or kink the Air Tubing. Cut the Air Tubing at an angle. Use pliers, scissors, snips, saws, or side cutters.

### PROPER AND IMPROPER CUTS IN THE AIR TUBING

<p>Square cut AIR TUBING 90°</p>	<p>AIR TUBING</p>	<p>AIR TUBING</p>	<p>AIR TUBING</p>
--	-------------------	-------------------	-------------------

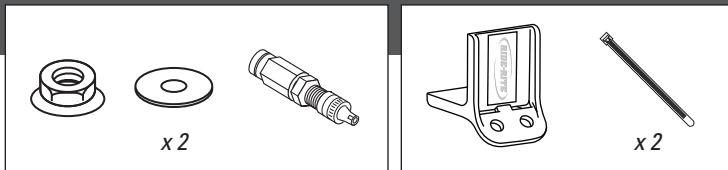

IF USING THE OPTIONAL NO-DRILL INFLATION VALVE BRACKET, CHOOSE OPTION 1. IF DRILLING, CHOOSE OPTION 2. **INFLATION VALVE MUST BE ACCESSIBLE BY AN AIR CHUCK.**

**1** Secure the Air Inflation Valve Bracket to a protected, secure location. **PROCEED TO STEP 3.**

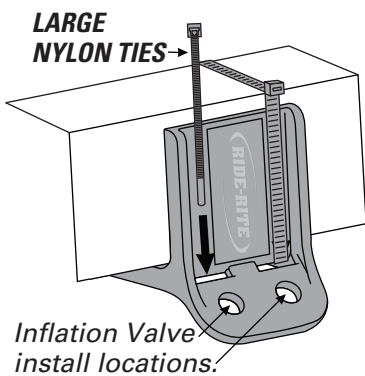

**2** Select a protected location to install the Inflation Valve, such as the bumper or the body of the vehicle.

Drill a 5/16" hole for Inflation Valve install location.

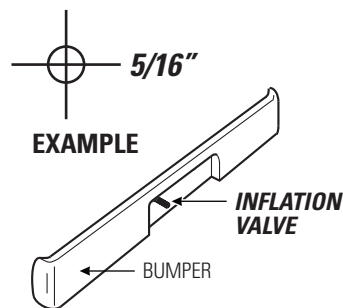

**3** Install Inflation Valve Assembly as shown.

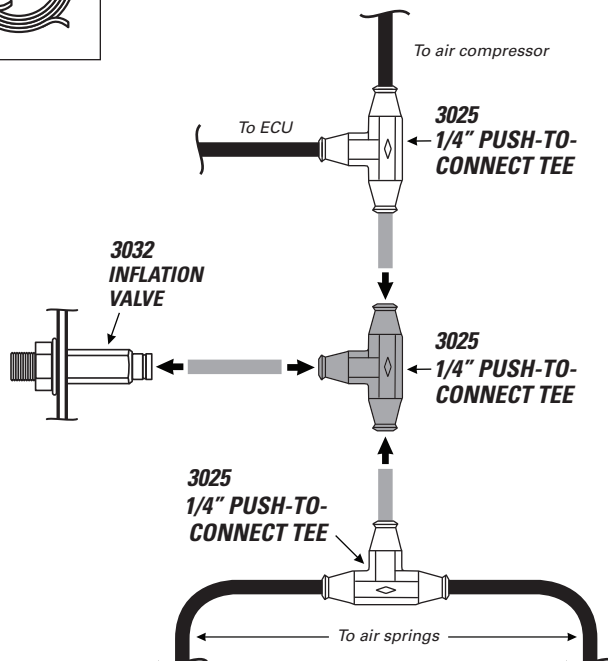
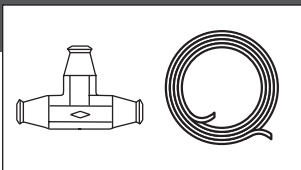
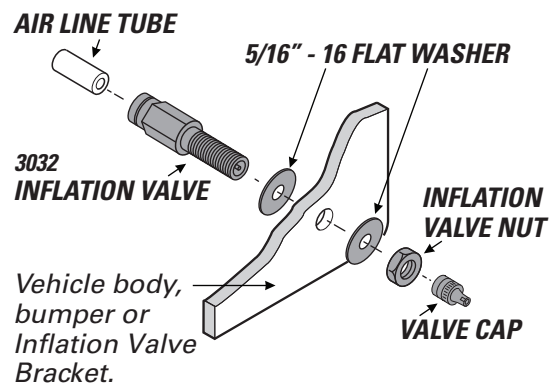

**1** Run Air Tubing from the location of the installed Inflation Valve in Step 6 to the Air Tubing that connects the two installed 1/4" Push-to-Connect Tees.

**2** Cut the piece of Air Tubing that connects the two installed 1/4" Push-to-Connect Tees.

**3** Install the Air Tubing into the 1/4" Push-to-Connect Tee, as shown.

**4** Install the Air Tubing into the Inflation Valve, as shown.

# 8

## INSTALLING THE AIR FILTER

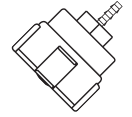

FILTER LIFE WILL VARY BASED ON ENVIRONMENTAL CONDITIONS. PROTECT THE AIR COMPRESSOR BY CHANGING THE AIR FILTER MORE FREQUENTLY IN DUSTY CONDITIONS.

**1** Fully secure the Air Filter Barb into the Air Tubing from the Air Compressor Kit.

**2** Press Air Tubing onto the Barb on the Air Compressor Air Fitting until fully seated. Assure you create a loop in the Air Tubing, as shown, when securing it to the vehicle.

**3** Periodically check the Air Filter during operation. When the Air Filter is dirty and needs to be replaced, contact an Authorized Firestone dealer to purchase a new one.



SECURE THE AIR FILTER IN A LOCATION THAT PROTECTS IT FROM MOISTURE AND DEBRIS, AND IS ABOVE THE LOOP IN THE AIR LINE TUBE.

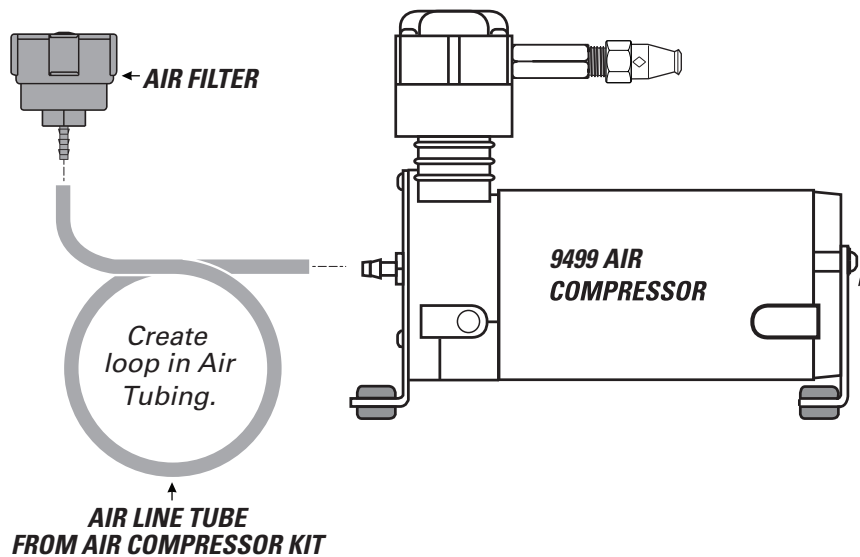

# 9

## CLEAN UP INSTALLATION



**1** Clean up the installation using supplied Nylon Ties, and return all factory parts and materials to operative state.



USING SUPPLIED NYLON TIES, SECURE ALL WIRING AND AIR LINE TUBE IN A MANNER THAT DOES NOT OBSTRUCT MOVING PARTS OR IN ANY WAY THAT AFFECTS YOUR ABILITY TO SAFELY OPERATE THE VEHICLE.

1 Download and install the Firestone Air Command app on a compatible iPhone or Android device.

2 Open the app. Once the app has established a Bluetooth connection on startup, it will automatically link to the ECU.

**MAIN APP SCREEN**

**SETTINGS**

**NEEDLE AND BAR**  
Shows actual pressure. Can be used to change pressure.

**ACTUAL PRESSURE**

**UNITS**

**MEMORY BUTTONS**  
To set memory, hold down target pressure, then press M1 or M2.

**DECREASE PRESSURE**

**INCREASE PRESSURE**

**TARGET PRESSURE**  
Set by user.

**SETTINGS**

**APP AND ECU INFORMATION**

**CONNECTION SCREEN**

**CHANGE PASSKEY** - User set or default (1234).

**MAIN APP SCREEN**

**SHOW FAULTS SCREEN\***

**SHOW SYSTEM STATUS SCREEN**

**SHOW LOG SCREEN FOR TROUBLESHOOTING**

\* Any faults will include troubleshooting instructions

# 12

## TEST THE SYSTEM

With the Air Command™ App and your air springs installed, you are ready to test the system.

- 1 Reattach the negative battery cable.

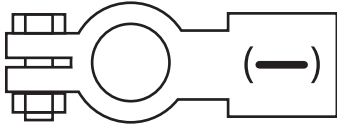

- 2 Turn on your vehicle's ignition.

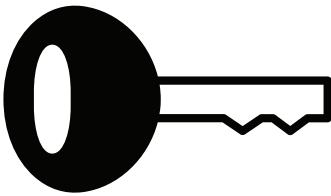

- 3 Use the Air Command™ App or Single Remote to inflate the Air Springs to 70 PSI. See Step 10 or 11 for details.

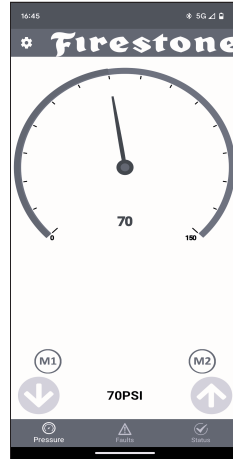

- 4 Spray fittings with soap and water mixture or glass cleaner.



- 5 Observe bubbles.

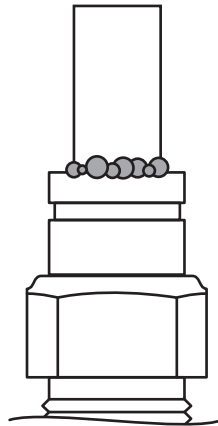

**SMALL SOAP BUBBLES  
THAT DO NOT EXPAND**

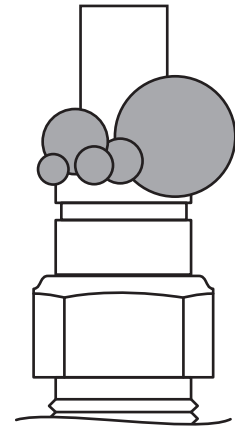

**SOAP BUBBLES  
THAT EXPAND**



# NO LEAKS?

Congratulations! You're riding right with the push of a button! Remember to review the Operating Instructions.

# LEAK?

Bummer. Continue to step 13 to fix the leak.



EXHAUST ALL AIR FROM THE SYSTEM PRIOR TO RELEASING AIR TUBES FROM AIR FITTINGS.



- 1 Use the Air Command™ App or Single Remote to deflate the Air Springs to 5 PSI. See Step 10 or 11 for details.

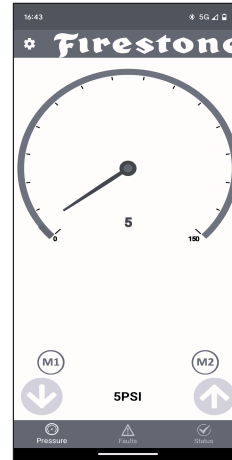

#### LEAK AT AIR TUBING AND AIR FITTING

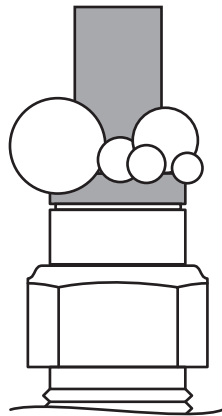

Release Air Tubing (see page 4). Review proper cuts and procedures in step 5. Repeat step 5.

#### LEAK AT BASE OF AIR FITTING

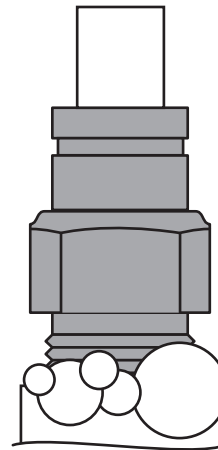

Tighten Air Fitting one turn or until leak stops.

## STILL HAVE A LEAK?

Refer to the Troubleshooting section of the Instruction Manual. If the leak persists, or if there is an issue with a leaking part, email us at [rrtech@fsip.com](mailto:rrtech@fsip.com). If emailing, please include photos to help us better diagnose and understand any problems you may be experiencing.



# AIRIDE

[firestoneairide.com](http://firestoneairide.com)

## BEFORE YOU DRIVE, CONFIRM THE FOLLOWING:

- Secure all AirTubing and wiring.
- The system passes the leak test and holds air.
- The Air Compressor ground ring terminal is contacting bare metal, and coated with silicone if possible.
- The Wire Harness is grounded to the negative (-) battery terminal. The ECU needs a good, clean, interference-free ground.
- There is a loop in the AirTubing as shown to prevent water or debris from getting into the Air Compressor head and damaging it.

Or, email us at [rrtech@fsip.com](mailto:rrtech@fsip.com). If emailing, please include photos to help us better diagnose and understand any problems you may be experiencing.

CONNECT WITH US



@firestoneairide



FirestoneAiride



Firestone Airide





**AIRIDE**

firestoneairide.com

# INSTALLATION INSTRUCTIONS

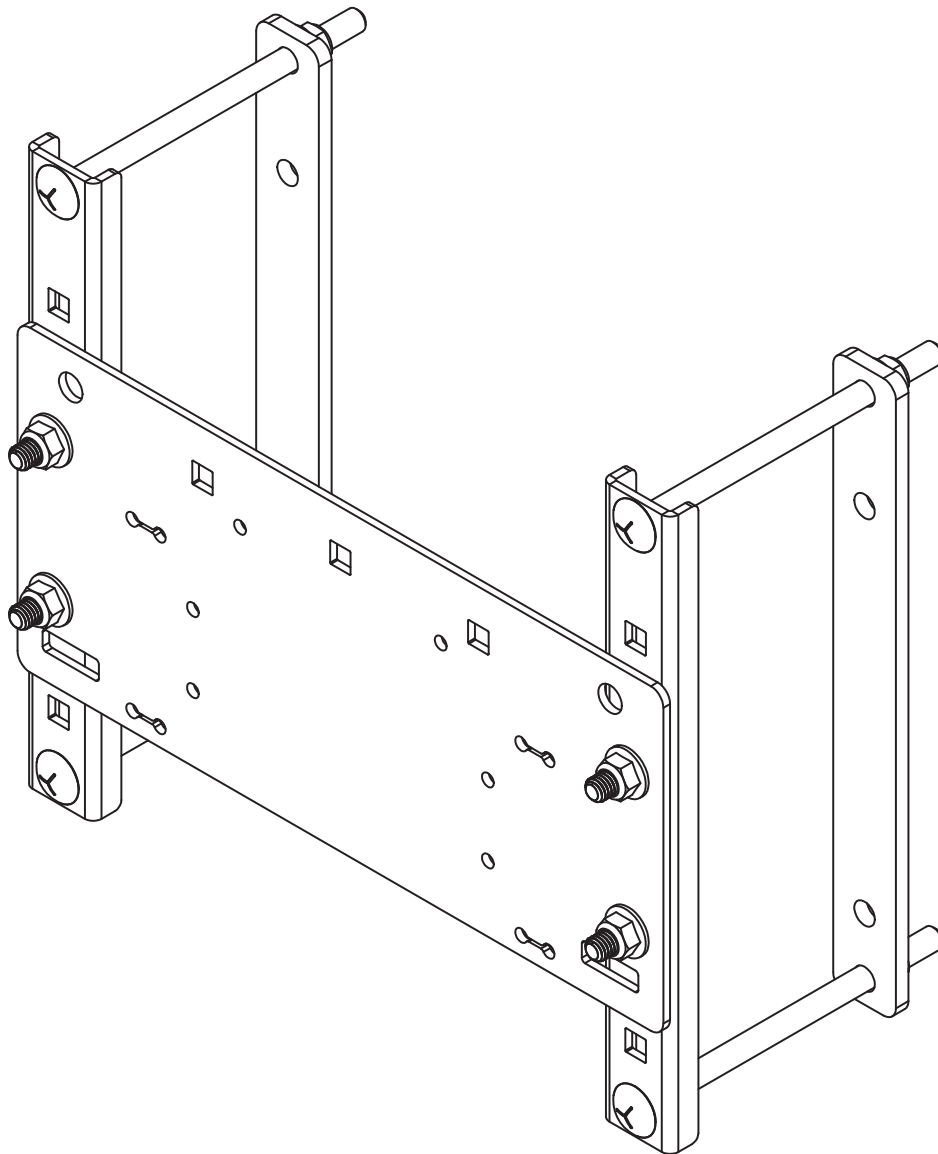

# ! IMPORTANT

PLEASE DON'T HURT YOURSELF, YOUR KIT OR YOUR VEHICLE. TAKE A MINUTE TO READ THIS IMPORTANT INFORMATION.

DO NOT INSTALL IF THE TRUCK HAS BEEN LIFTED AND THE STOCK JOUNCE BUMPER SPACERS ARE NOT ON THE VEHICLE. *This kit is to be used on a pickup truck only, and DOES NOT INCREASE YOUR VEHICLE'S MAXIMUM LOAD.*

## SAFE INSTALLATION

Please take all safety precautions during installation. A hydraulic jack can fail, and if that happens, you can be seriously hurt, or worse, if you are relying on it to hold up the vehicle. If you use a hydraulic jack, secure jack stands in the appropriate locations and chock any tires still touching the ground.

Wear safety glasses or goggles. Your eyes may be lower than some parts and pieces, and you don't want to lose an eye.

Remove the possibility of any electrical issues by disconnecting the negative battery cable.

## KIT USES

This kit works with Air Command Kits 2920, 2921, 2922, and 2923. Refer to the following pages for kit-specific layouts to ensure all of the components fit onto the Compressor Mount Plate.

## VEHICLE GVWR

NEVER exceed the maximum load recommended by the vehicle manufacturer (GVWR). The GVWR can be found in your vehicle's owner's manual or on the data plate on the driver's side door.

## INFLATING THE AIR SPRINGS

When inflating air springs, add air pressure in small quantities, checking air pressure frequently. The air springs have much less air volume than a tire, so they inflate much more quickly.

## APPROPRIATE AIR PRESSURE

For best ride, use only enough air pressure in the air springs to level the vehicle when viewed from the side (front to rear). This will vary, depending on the load, location of the load, condition of the existing suspension, and personal preference.



# PARTS

Compare the parts below to your kit. Ensure you have all pieces, and organize them for an easier installation.

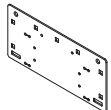
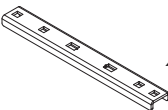
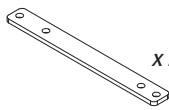
## MAIN KIT CONTENTS

PT # 5694	 x 1 NO DRILL COMPRESSOR PLATE	PT # 5965	 x 2 PLATE CHANNEL MOUNT	PT # 5966	 x 2 BACKING PLATE
-----------	--	-----------	---	-----------	--

## A21-760-2642 HARDWARE PACK

PT # 3067	 x 8 3/8"-16 HEX HEAD FLANGE NYLOCK NUT	PT # 3072	 x 4 3/8"-16 X 1" CARRIAGE BOLT	PT # 3502	 x 8 3/8"-16 X 6" CARRIAGE BOLT
-----------	---	-----------	---	-----------	---

- 1 Mount the No-Drill Compressor Plate to the Plate Channel Mounts shown below.
- 2 Align the Compressor Plate to the bottom of the slots in the Plate Channel Mount.
- 3 Select a suitable location for installation on the vehicle frame rail. Take a tape measure to get a rough height of the frame rail. Use that measurement to determine which holes to use in the mounting plates (distances between holes shown below). It is recommended to mount to the passenger side frame rail as the vehicle's battery is normally located in the engine compartment on the passenger side. Double check before final installation.

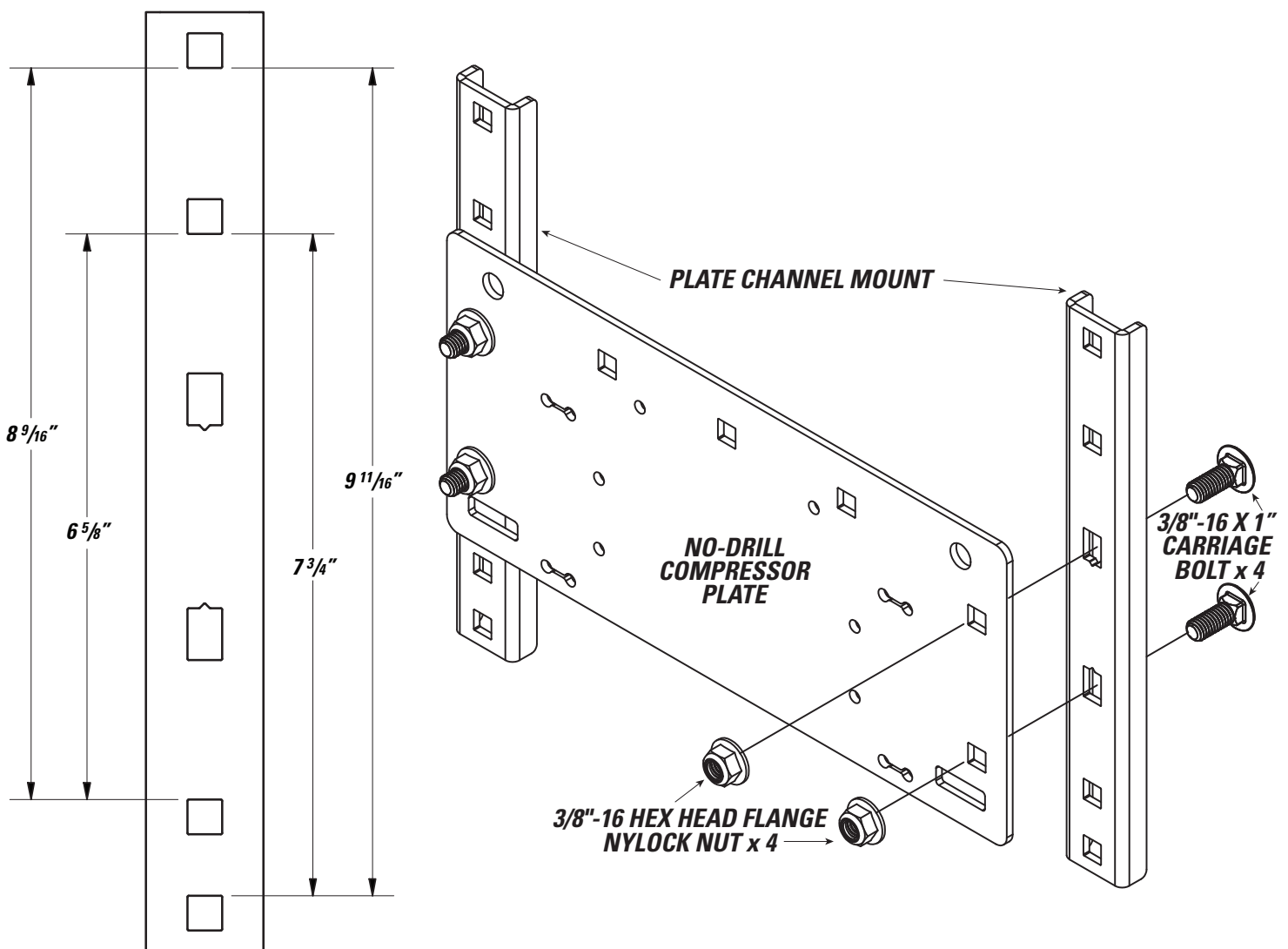

# 2

## INSTALL THE ECU

Fasteners included in Air Command Kit



x 2



x 2



x 2



DO NOT OVERTIGHTEN MOUNTING BOLTS AND NUTS ON THE ECU. TOO MUCH TORQUE CAN CRACK THE PLASTIC FEET ON THE ECU.

**1** Mount the ECU to the hole locations in the Compressor Plate using the supplied fasteners. DO NOT OVERTIGHTEN.

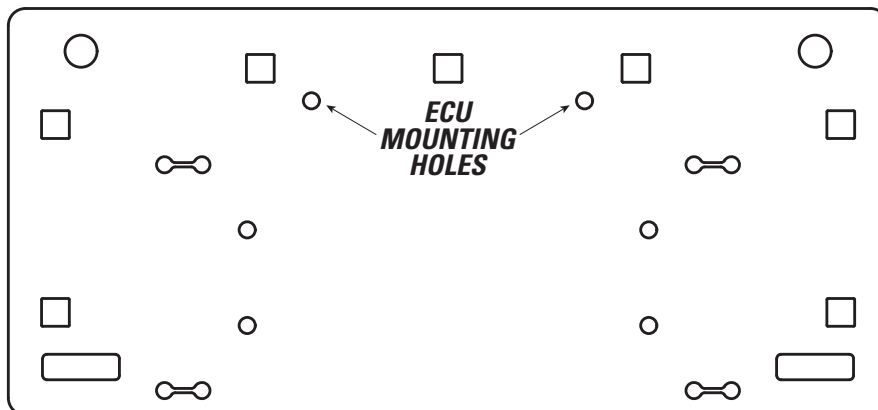
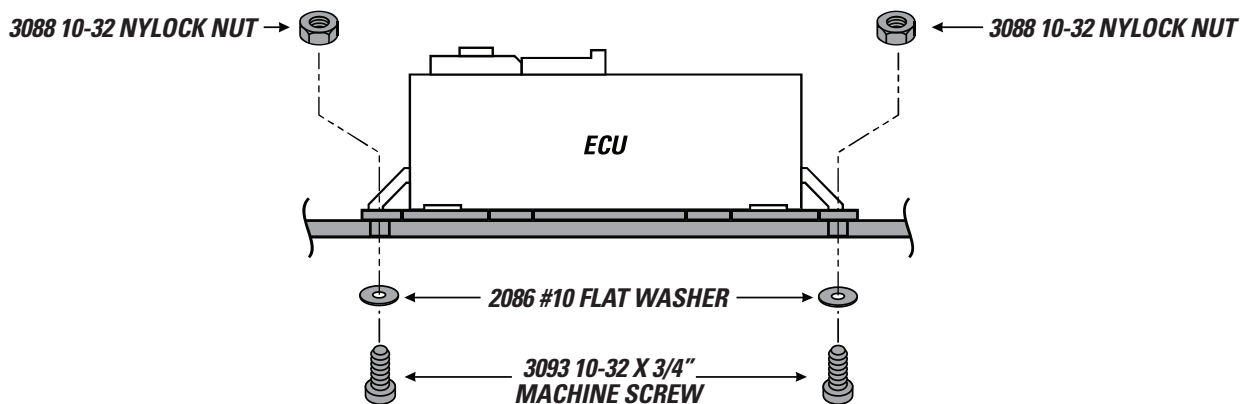

Fasteners included in Air Command Kit

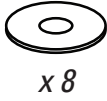

DO NOT OVER TIGHTEN MOUNTING BOLTS AND NUTS ON THE AIR COMPRESSOR. TOO MUCH TORQUE CAN CRUSH THE BRASS INSERTS AND RUBBER ISOLATORS.



**1** Mount the Air Compressor to the hole locations in the Compressor Plate using the supplied fasteners. DO NOT OVERTIGHTEN.

**2** It is recommended to face the outlet of the compressor towards the air springs on the rear axle of vehicle.

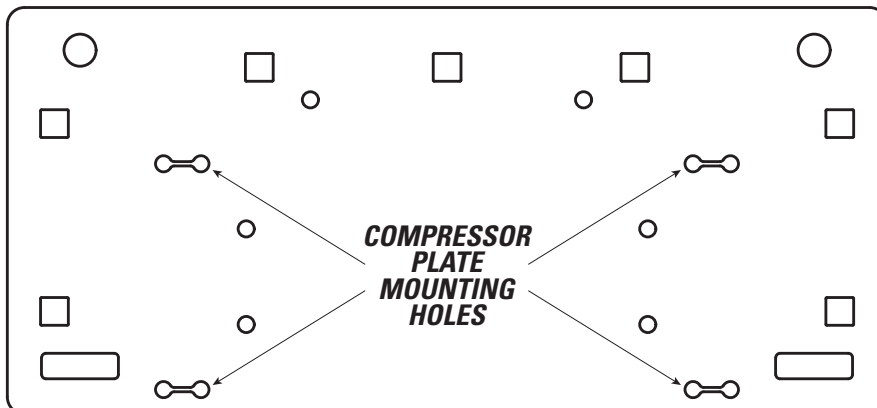
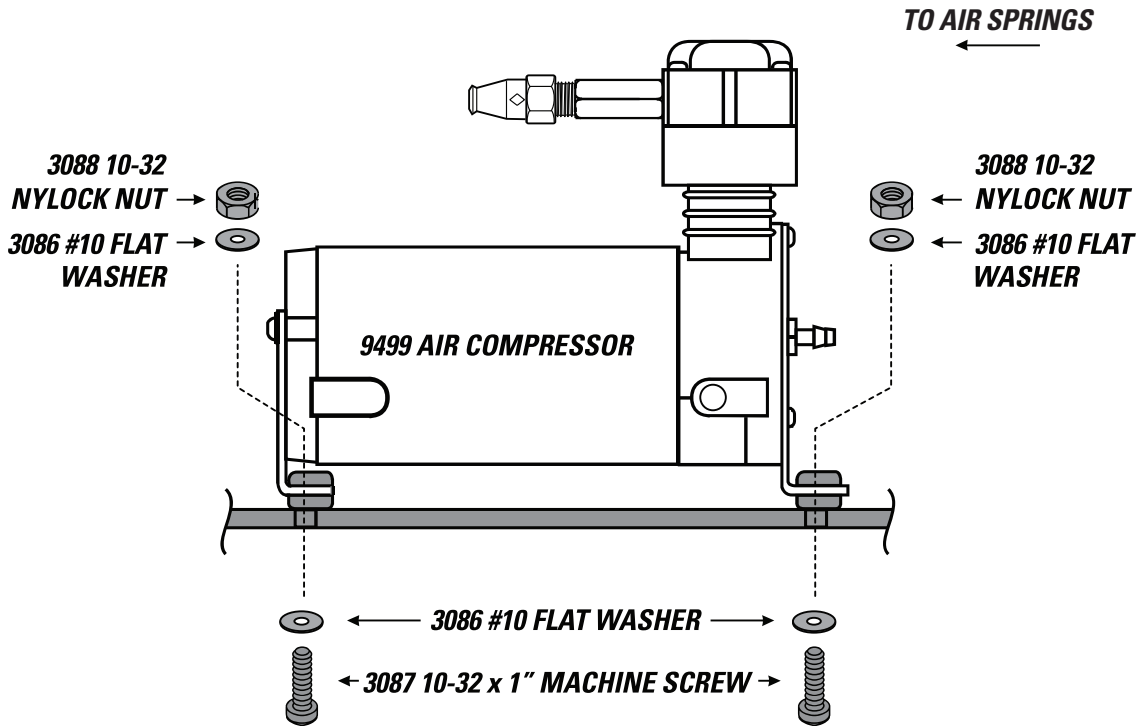

# 6

## MOUNTING TO THE VEHICLE - USE FOR HEAVY DUTY AIR COMMAND KITS 2921 & 2923



AIR ACCESSORY MOUNTING KIT CANNOT BE USED AS A GROUNDING LOCATION FOR THE AIR COMPRESSOR

**1** Install the compressor bracket assembly to the vehicles frame rail, using whichever carriage bolt holes are closest to the top and bottom of the vehicle frame as was determined in Step 1.

### RECOMMENDED

**2** Follow Air Command Kit instructions to run air line from the Air Compressor to the ECU.

**3** Continue following the Air Command Kit instructions to connect all air tubing and electrical wiring.

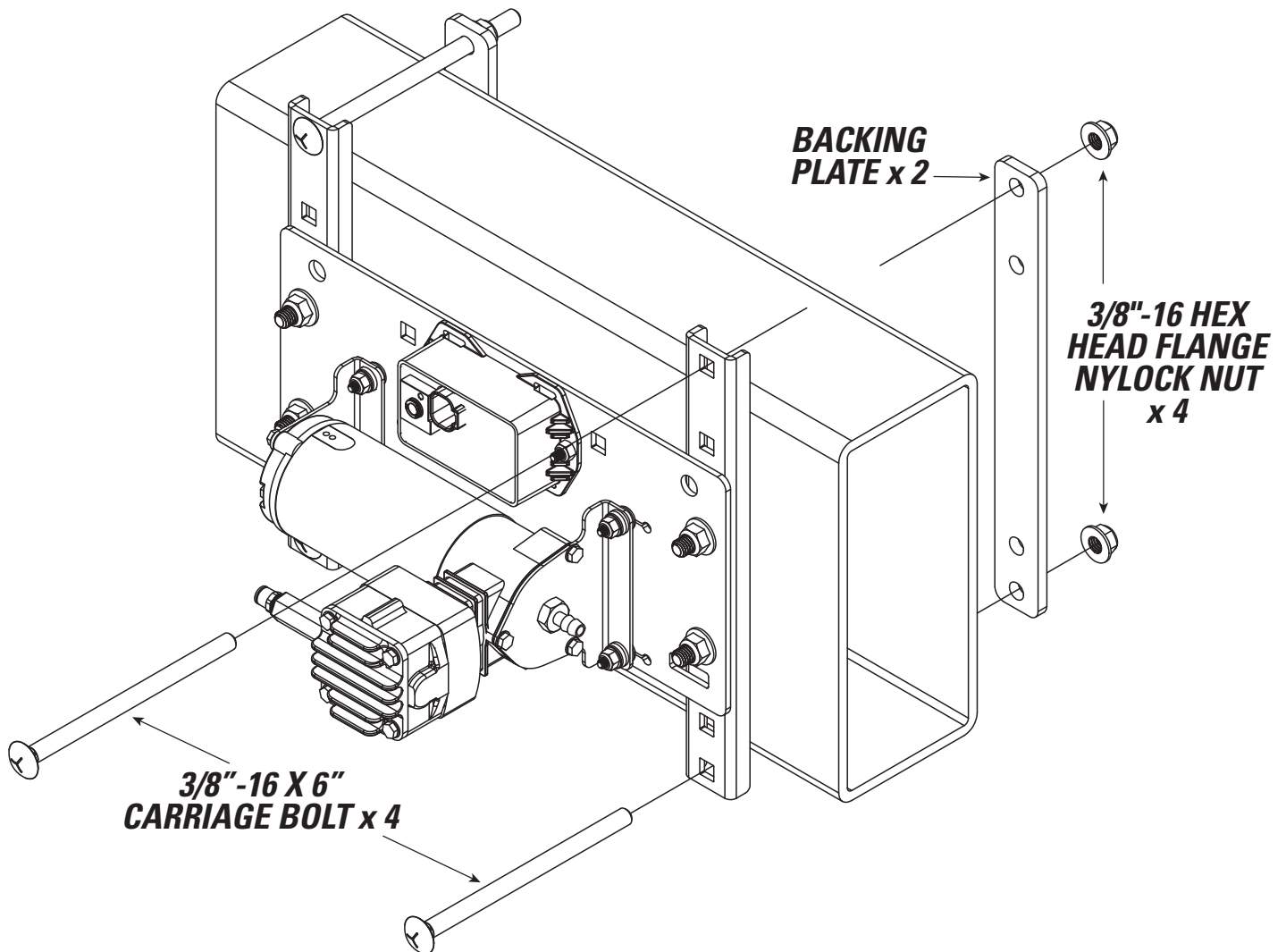

# NOTES

---

---

---

---

---

---

---

---

---

---

---

---

---

---

---

---

---

---

---

---

---

---

---

---



# AIRIDE

[firestoneairide.com](http://firestoneairide.com)

## BEFORE YOU DRIVE, CONFIRM THE FOLLOWING:

- Make sure all fasteners are tight and secure.
- Make sure the installation does not interfere with any other components on the vehicle.
- Reattach negative battery cable.

## NEED INSTALLATION HELP?

Email us at [rrtech@fsip.com](mailto:rrtech@fsip.com). Please include photos, kit number, and the year, make, and model of the vehicle to help us better diagnose and understand any problems you may be experiencing.

CONNECT WITH US



@firestoneairide



FirestoneAiride



Firestone Airide