

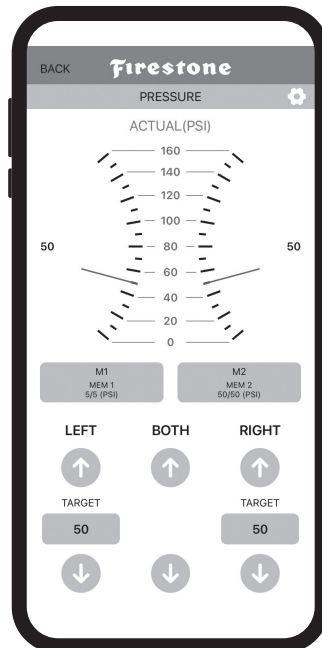

AIRIDE

firestoneairide.com

INSTALLATION INSTRUCTIONS

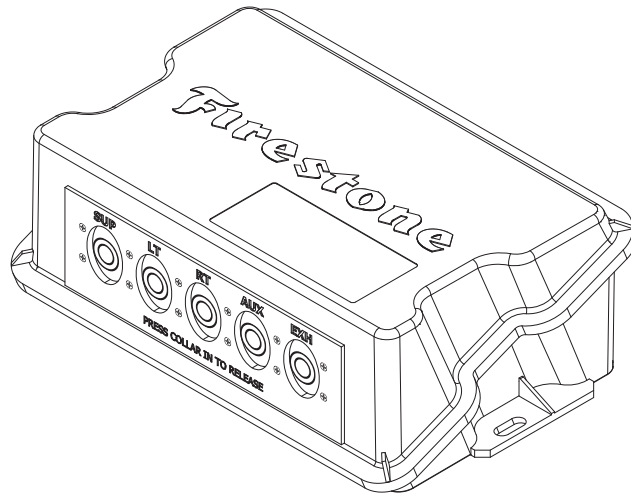

IMPORTANT

PLEASE DON'T HURT YOURSELF, THE KIT, OR YOUR VEHICLE. TAKE A MINUTE TO READ THIS IMPORTANT INFORMATION.

SAFE INSTALLATION

Please take all safety precautions during installation. A hydraulic jack can fail, and if that happens, you can be seriously hurt, or worse, if you are relying on it to hold up the vehicle. If you use a hydraulic jack, secure jack stands in the appropriate locations and chock any tires still touching the ground.

Wear safety glasses or goggles. Your eyes may be lower than some parts and pieces, and you don't want to lose an eye.

Remove the possibility of any electrical issues by disconnecting the negative battery cable.

VEHICLE GVWR

NEVER exceed the maximum load recommended by the vehicle manufacturer (GVWR). The GVWR can be found in your vehicle's owner's manual or on the data plate on the driver's side door. Consult your local dealership for additional GVWR specifications.

PRESSURE TO LOAD

Be sure to review the load limits noted in the Air Spring Kit Installation Instructions (sold separately).

APPROPRIATE AIR PRESSURE

For best ride, use only enough air pressure in the Air Springs to level the vehicle when viewed from the side (front to rear). This will vary, depending on the load, location of the load, condition of the existing suspension, and personal preference.

**ONCE INSTALLED SUCCESSFULLY, FOLLOW THE PRESSURE REQUIREMENTS FOR THE AIR SPRINGS.
FOR FIRESTONE, GENERALLY:**

COIL-RITE





RIDE-RITE



PARTS

Compare the parts below to your kit. Assure you have all pieces, and organize them for an easier installation.

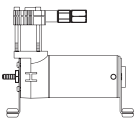
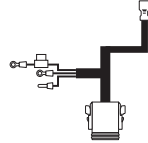





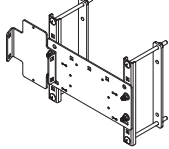



MAIN KIT CONTENTS

PT # 9965 <i>The 9961 ECU and 9962 Wire Harness are packaged inside one box under the 9965 part number.</i>	PT # 9961  x 1 ECU	PT # 9523  x 1 AIR COMPRESSOR KIT
	PT # 9962  x 1 WIRE HARNESS	PT # 9415  x 1 AIR TUBING (22 FEET)

A24-760-2644 COMPRESSOR AND ECU MOUNTING KIT

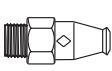
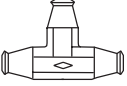
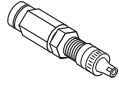
KIT # 2644  x 1 DUAL PATH MOUNTING KIT <i>The parts list for this kit is in the Mounting Kit Manual included at the end of this Manual.</i>

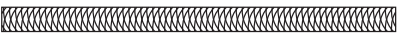
A21-760-2930 HARDWARE PACK

PT # 3087  x 4 10-32 x 1" MACHINE SCREW	PT # 3093  x 2 10-32 x 3/4" MACHINE SCREW	PT # 3086  x 10 #10 FLAT WASHER
PT # 3088  x 6 10-32 NYLOCK NUT	PT # 3421  x 1 10-16 x 3/4" SELF-TAPPING SCREW	PT # 9483  x 1 INFLATION VALVE MOUNTING BRACKET
PT # 3055  x 1 1/8 NPT PUSH-TO-CONNECT STRAIGHT FITTING	PT # 3025  1/4 PUSH-TO-CONNECT TEE	PT # 3032  x 2 INFLATION VALVE AND VALVE CAP ASSEMBLY
PT # 9488  x 4 LARGE NYLON TIE	PT # 0899  x 2 THERMAL SLEEVE	PT # 9036  x 15 RED NYLON TIE

CONTENTS AND OVERVIEW

PAGE 4	PLANNING THE INSTALL
PAGE 5	PREPARE THE AIR COMPRESSOR
PAGE 6	DRILL HOLES FOR AIR COMPRESSOR AND ECU
PAGE 7	INSTALL THE AIR COMPRESSOR AND ECU
PAGE 8	INSTALL THE AIR TUBING
PAGE 9	INSTALL THE WIRE HARNESS
PAGE 10	INSTALL THE AIR FILTER AND CLEAN UP
PAGE 11	ECU POWER UP/ APP PERFORMANCE
PAGE 13	USING THE AIR COMMAND™ DUAL APP
PAGE 15	TEST THE SYSTEM
PAGE 16	FIX AN AIR LEAK

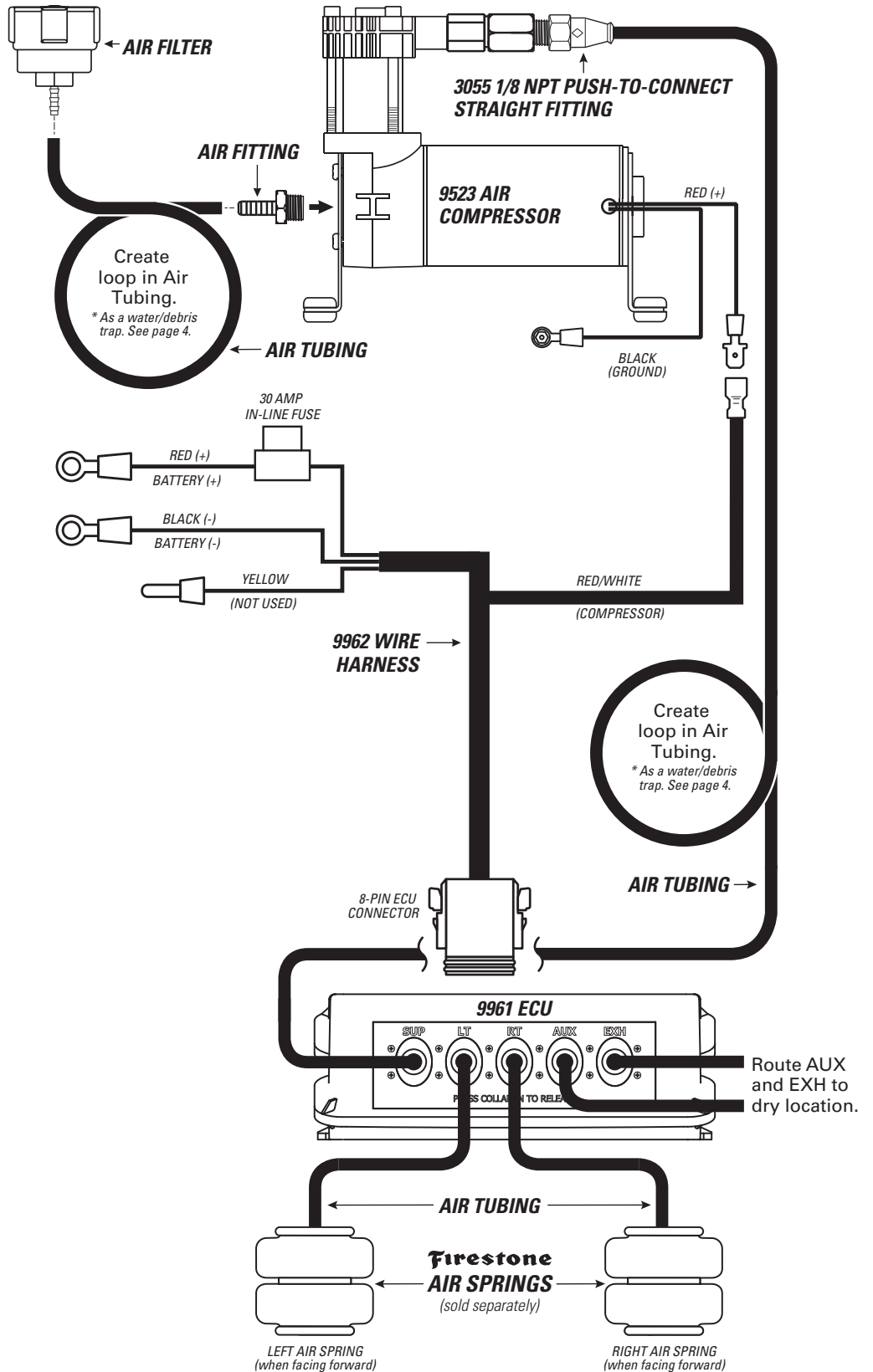

PLANNING THE INSTALL

THESE PLANNING STEPS WILL HELP YOU SAVE TIME AND WILL MAKE THE INSTALLATION EASIER.

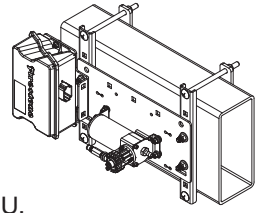

DETERMINE THE MOUNTING LOCATION FOR THE AIR COMMAND KIT

- This Kit comes with a Mounting designed specifically for the provided Air Compressor and ECU.
- Refer to the Mounting Kit Manual attached at the end of this Kit's Manual for additional instructions.
- Consult the **OPTIONAL** instructions below and in Section 2 only if the Mounting Kit does **NOT** fit your vehicle.

PLAN INSTALLATION ROUTES FOR WIRING AND AIR LINES

- Make sure the Wire Harness and Air Tubing are not exposed to sharp metal edges that can damage them.
- Use supplied Thermal Sleeves on Air Tubing when routing near heat sources.
- Use supplied Nylon Ties to secure Air Tubing and Wire Harness to the vehicle.
- Make a loop in the Air Tubing where shown. This creates a water/debris trap that protects the Air Compressor.
- Measure twice, cut once!

TAPE ALL ELECTRICAL CONNECTIONS

- Use electrical tape to appropriately secure and protect all electrical connections.

USING PUSH-TO-CONNECT FITTINGS FOR AIR LINES

Your kit includes Push-to-Connect fittings to connect the Air Tubing to hardware. Use the instructions below when using the Air Tubing.

- 1** Insert end of Air Tubing into Air Fitting.

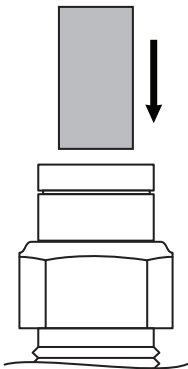

- 2** Push Air Tubing into Air Fitting as far as possible.

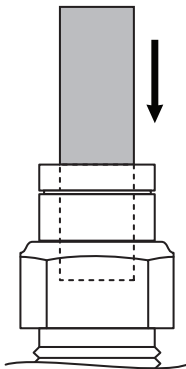

- 3** Gently pull on the Air Tubing to check for a secure fit.

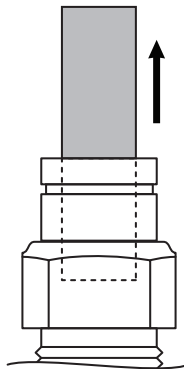

- 4** To remove, push down collar and gently pull Air Tubing away.

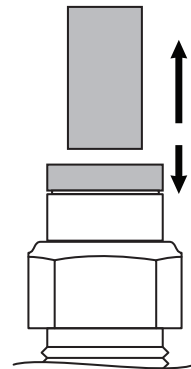

Removal Tip: Use a 1/4", 5/16", or 6mm open-ended wrench to push the collar down.

OPTIONAL

DETERMINE THE MOUNTING LOCATION FOR THE AIR COMPRESSOR AND ECU

- Mount in a location protected from airborne debris and moisture.
- Allow room for the Air Tubing to run without sharp curves or bends.
- Allow room for the Tubing to connect to the Air Fitting on the ECU.
- Allow room for the 4-pin ECU connector to connect to the ECU.
- Mount close enough together to allow Wire Harness connections to reach the Air Compressor and ECU.
- Using supplied fasteners shown in Step 3 is recommended. If no other mounting option is available, see the sidebar on Step 2 for using the Large Nylon Ties.
- Select a location that is solid and secure on the body or frame of the vehicle, away from any moving parts, electrical or any other lines.

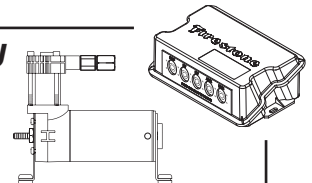

1

PREPARE THE AIR COMPRESSOR

NOTE: Air compressor can be mounted facing any direction.

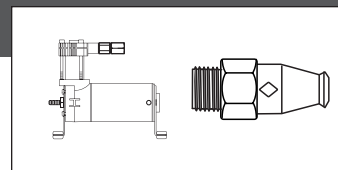

1 Install 1/8 NPT Push-to-Connect Straight Fitting on the Check Valve.

2 Install Barbed Air Fitting in Inlet Port of the Compressor from Air Compressor Kit.

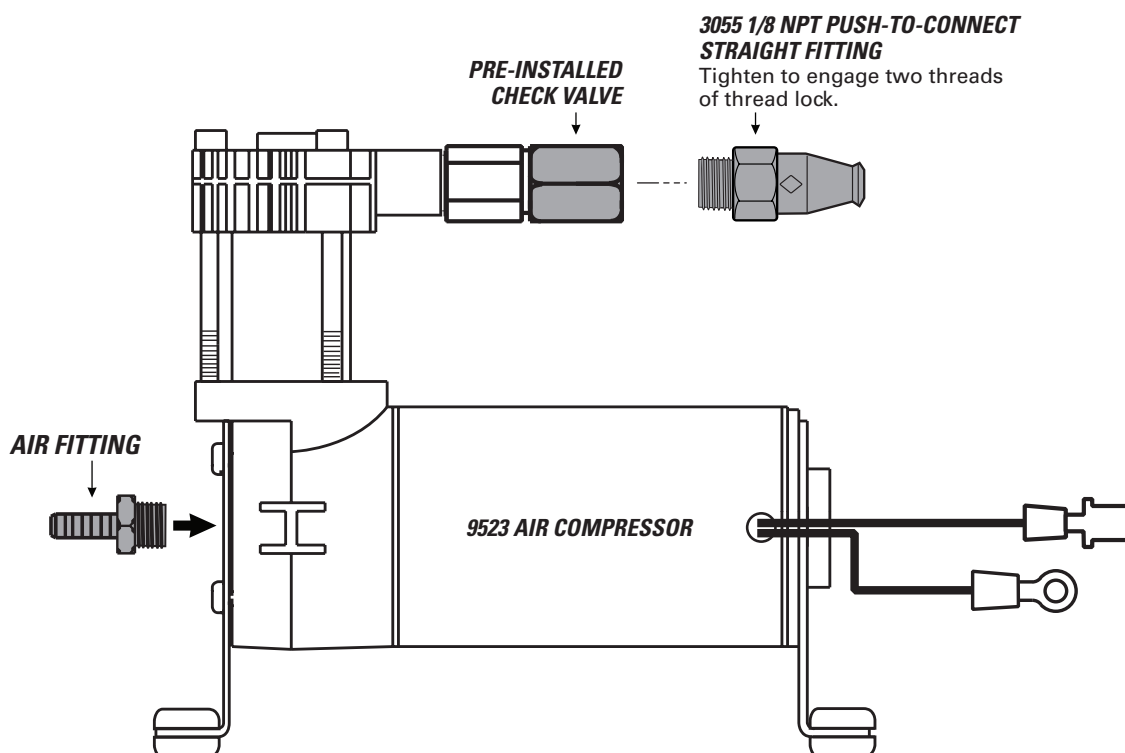

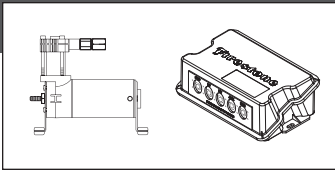

IF YOU ARE USING THE SUPPLIED FIRESTONE AIR ACCESSORY MOUNTING KIT, SKIP THIS STEP AND REFER TO THE MOUNTING KIT'S INSTRUCTIONS AT THE END OF THIS MANUAL.

STOP HERE AND SKIP THIS STEP IF USING THE PROVIDED MOUNTING KIT



CHECK SURROUNDING AREA AND BACK SIDE OF MOUNTING LOCATION TO AVOID DRILLING INTO EXISTING LINES OR WIRING.

Drill within reach of the ground wire ring terminal on body or frame of vehicle or create a wire to link to the negative battery terminal. Minimum gauge of wire should be 12.

AIR ACCESSORY MOUNTING KIT CANNOT BE USED AS A GROUNDING LOCATION FOR THE AIR COMPRESSOR.

1 Using the Air Compressor and ECU as templates, mark drill locations as shown with a punch or marking tool.

2 Mark Air Compressor ground wire fastening location within reach of the ground wire ring terminal.

3 Drill 7/32" diameter holes. Remove any burrs and debris from drill holes.

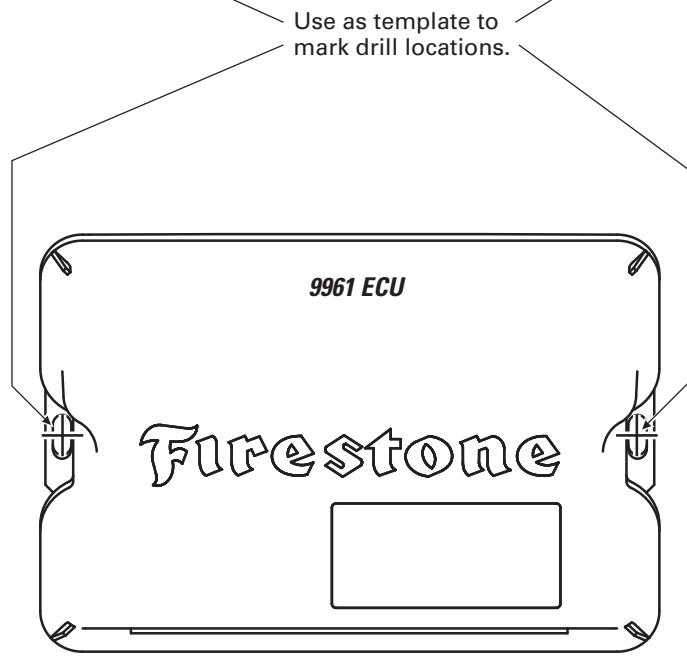
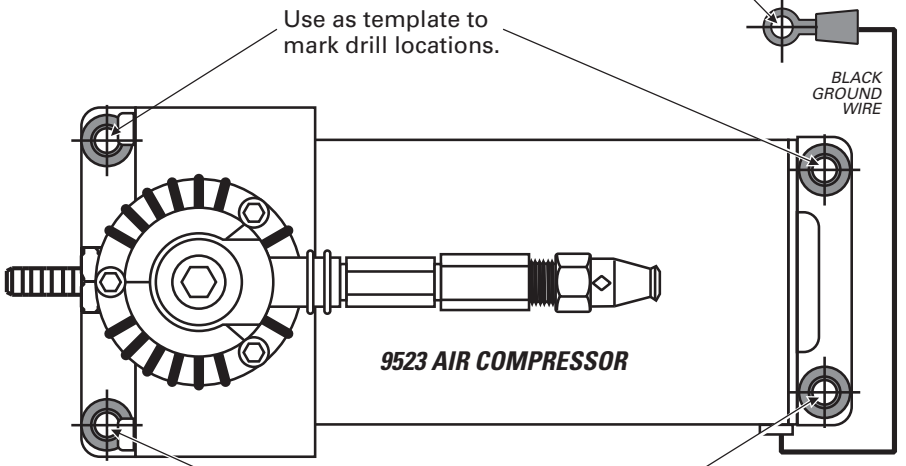

ASSURE THAT YOU INSTALL THE AIR COMPRESSOR AND ECU CLOSE ENOUGH SO THE CONNECTORS ON THE WIRE HARNESS WILL REACH THEM BOTH.

OPTIONAL ECU MOUNTING

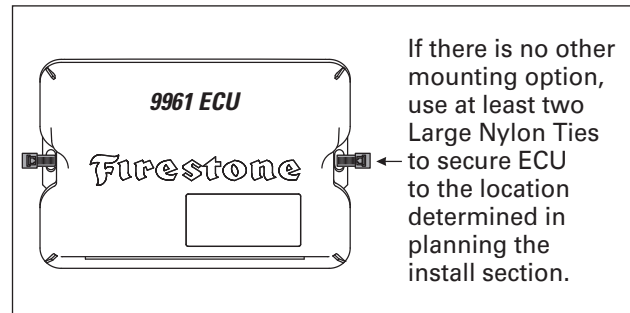

3

INSTALL THE AIR COMPRESSOR AND ECU

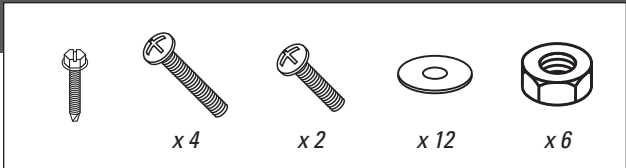

DO NOT OVER TIGHTEN MOUNTING BOLTS AND NUTS ON THE AIR COMPRESSOR. TOO MUCH TORQUE CAN CRUSH THE BRASS INSERTS AND RUBBER ISOLATORS.

1 Mount the Air Compressor to the hole locations on the provided Mounting Kit using the supplied fasteners. DO NOT OVERTIGHTEN.

2 Mount the ECU to the hole locations on the provided Mounting Kit using the supplied fasteners.

3 Mount the black ground wire ring terminal using the supplied fasteners. Assure that the ring terminal makes a solid contact with bare metal for a proper ground.

OPTIONAL

Mount to the drill holes made in the frame. Do this only if the mounting kit will not mount to the frame of the vehicle.

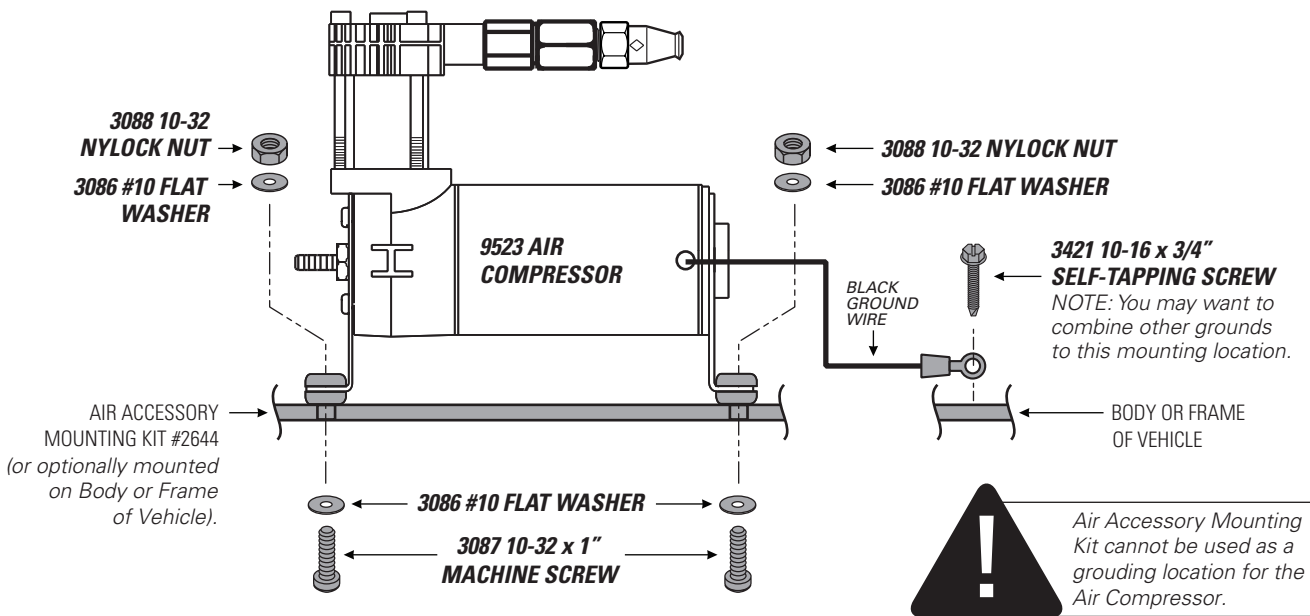

Air Accessory Mounting Kit cannot be used as a grounding location for the Air Compressor.

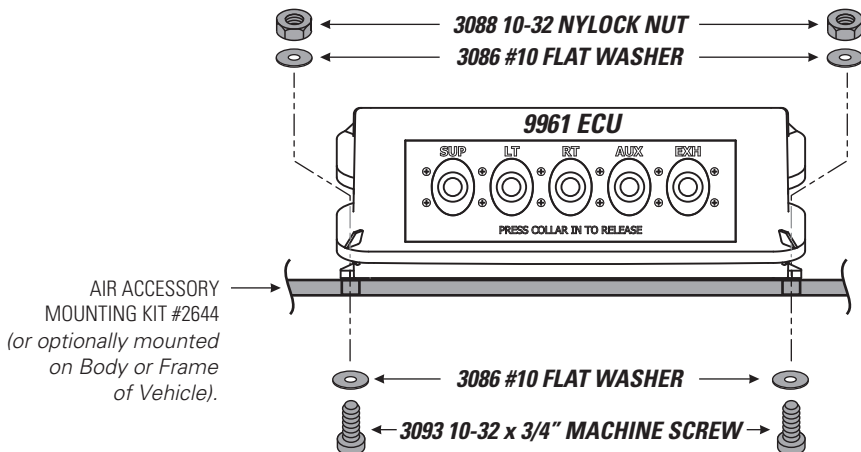

TOP VIEW

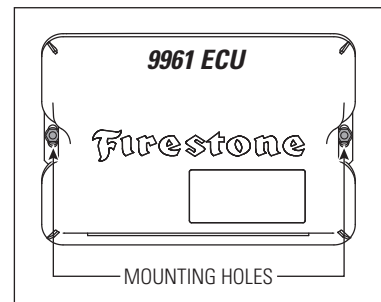



EXHAUST ALL AIR FROM THE SYSTEM PRIOR TO RELEASING AIR TUBING FROM AIR FITTINGS.



1 Route the Air Tubing from 1/8 NPT Push-to-Connect Straight Fitting on the top of the Air Compressor to the Supply (SUP) Air Fitting on the ECU, leaving room to secure it safely. Use the guidelines on page 4 for proper Push-to-Connect Straight Fitting install.

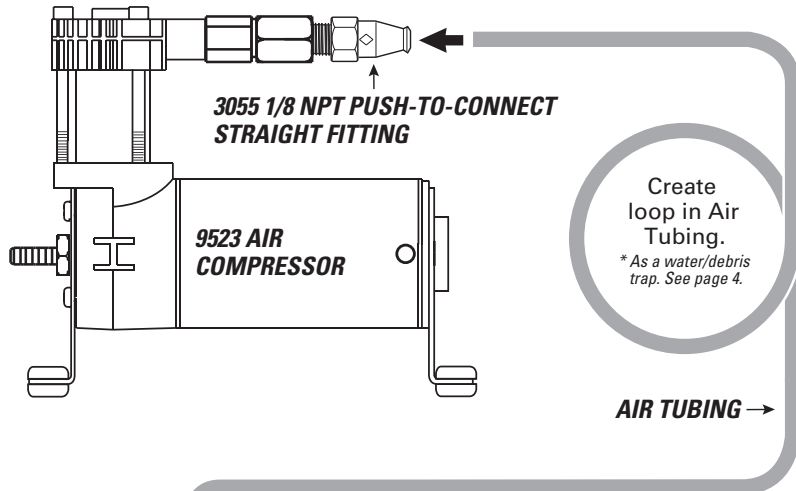

2 Repeat Step 1 to route Air Tubing from the ECU to the Air Springs. Use the RT and LT Air Fittings on the ECU.

3 Install Air Tubing to the Exhaust (EXH) Air Fitting to reduce exhaust noise and prevent dirt from clogging the port (recommended for off-road or dirty environments). Do not exceed 16" of Air Tubing, and secure it so the end turns to the ground.

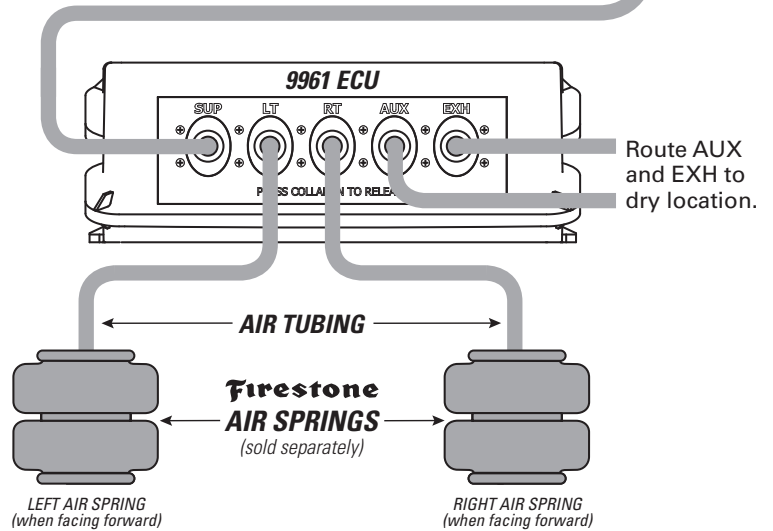

DO

Make sure the cut is as square as possible. Use a tube cutter or very sharp utility knife.

DON'T

Fold or kink the Air Tubing. Cut the Air Tubing at an angle. Use pliers, scissors, snips, saws, or side cutters.

PROPER AND IMPROPER CUTS IN THE AIR TUBING

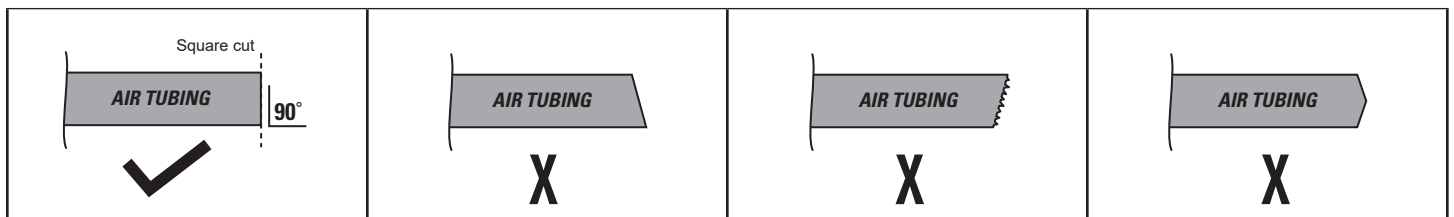

5

INSTALL THE WIRE HARNESS

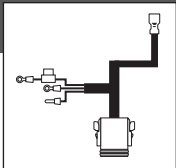

Why ground the Wire Harness to the battery? The ECU needs a good, clean ground for optimal accuracy. The Air Compressor can ground to the frame, but the ECU cannot.

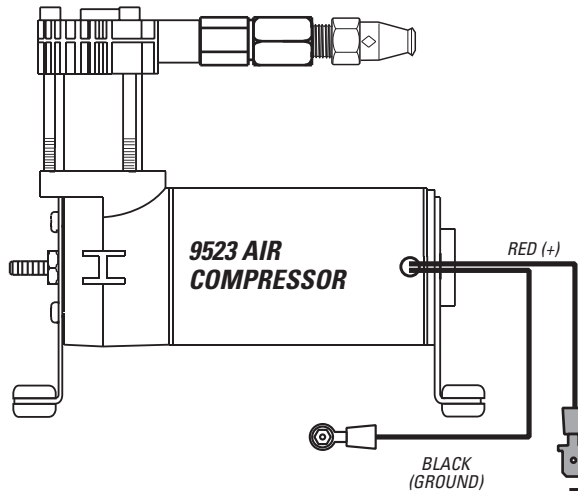

1 Route the Wire Harness in the most protected manner possible, and securely make all connections as shown.

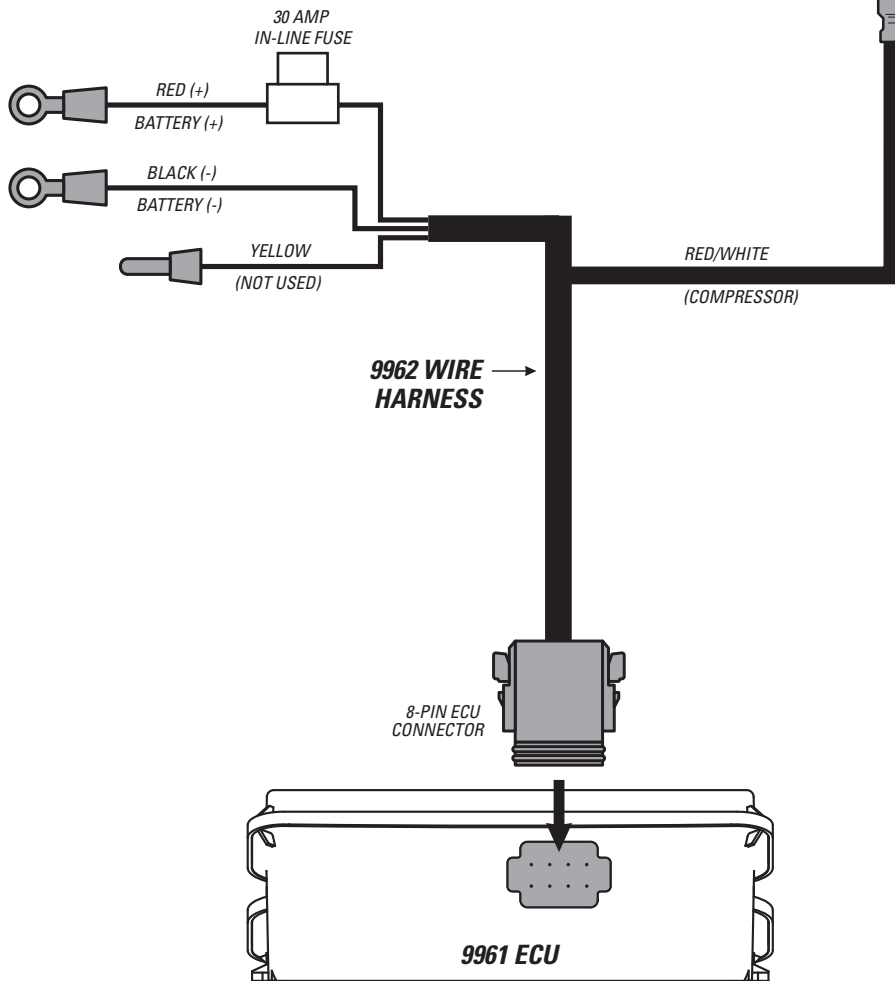

ECU INDICATOR LIGHTS (Inside Case)

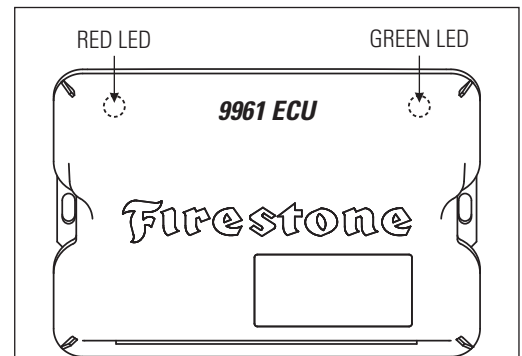

- LEDs off** – ECU off
- Red LED flashing** – Errors are present
- Green LED flashing** – Bluetooth not connected, normal operation
- Green LED solid** – Bluetooth connected, Normal operation

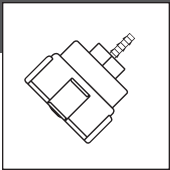

FILTER LIFE WILL VARY BASED ON ENVIRONMENTAL CONDITIONS. PROTECT THE AIR COMPRESSOR BY CHANGING THE AIR FILTER MORE FREQUENTLY IN DUSTY CONDITIONS.

1 Fully secure the Air Filter barb into the Air Tubing from the Air Compressor Kit.

2 Press Air Tubing onto the barb on the Air Compressor Air Fitting until fully seated. Assure you create a loop in the Air Tubing, as shown, when securing it to the vehicle.

3 Periodically check the Air Filter during operation. When the Air Filter is dirty and needs to be replaced, contact an Authorized Firestone dealer to purchase a new one.

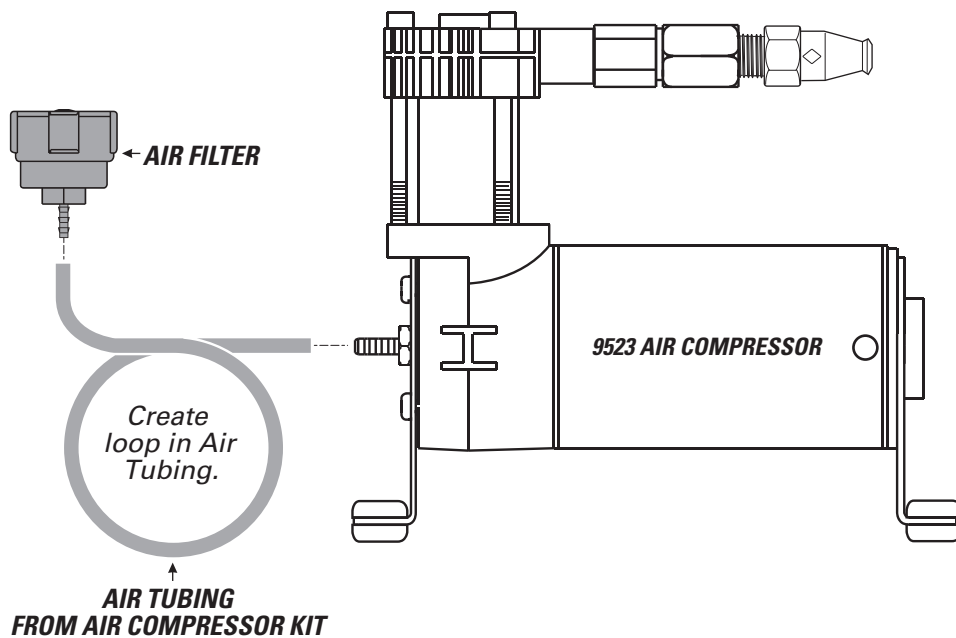

1 Clean up the installation using supplied Nylon Ties, and return all factory parts and materials to operative state.



USING SUPPLIED NYLON TIES, SECURE ALL WIRING AND AIR TUBING IN A MANNER THAT DOES NOT OBSTRUCT MOVING PARTS OR IN ANY WAY THAT AFFECTS YOUR ABILITY TO SAFELY OPERATE THE VEHICLE.

1 Download app from Google Play or Apple Store. Search for 'Air Command Dual'.

2 Start the vehicle and open app.

3 Select **SCAN** and click on the ECU from the screen.

4 Follow onscreen prompts to link to the ECU and press **NEXT**.

5 Default passkey is **123456**.

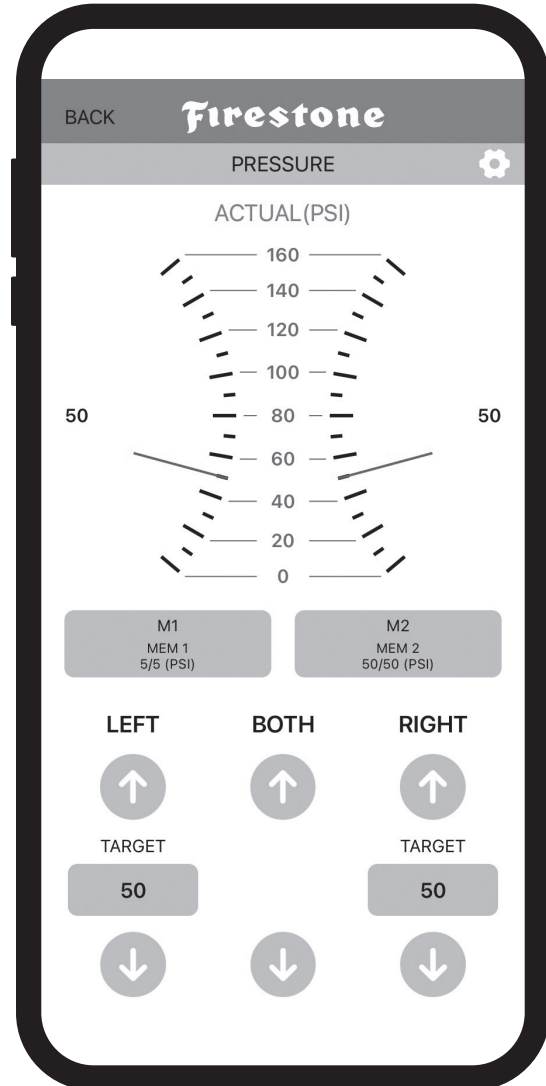

6 FACTORY RESET (TROUBLESHOOTING ONLY)

- Remove fuse from red wire by battery or remove wire harness connector from ECU
- Remove app from phone
- Reinstall fuse or plug wire harness connector back into the ECU
- Download the app

The ECU will remain active for two hours after initial installation or factory reset.

After voltage drop due to engine stop, the ECU will remain active for up to thirty minutes.

A SOLID GREEN LED
ON THE ECU INDICATES
BLUETOOTH IS CONNECTED

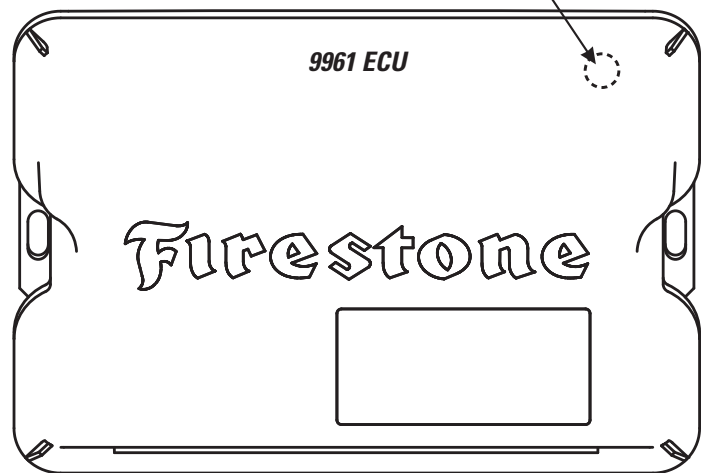

OVER THE AIR FIRMWARE UPDATE

If an OTA update is available, a popup will appear on the app to activate.

After voltage drop due to engine stop, the ECU will remain active for five minutes.

- If you select **SKIP**, the firmware can be updated once connected to the app
- If you select **INSTALL**, the firmware will begin to update. This will take approximately 3-4 minutes
- Keep the app open during the update and stay within range of the ECU until complete
- Once OTA is complete, restart the app, use the default passkey, and use as normal

MAIN SCREEN

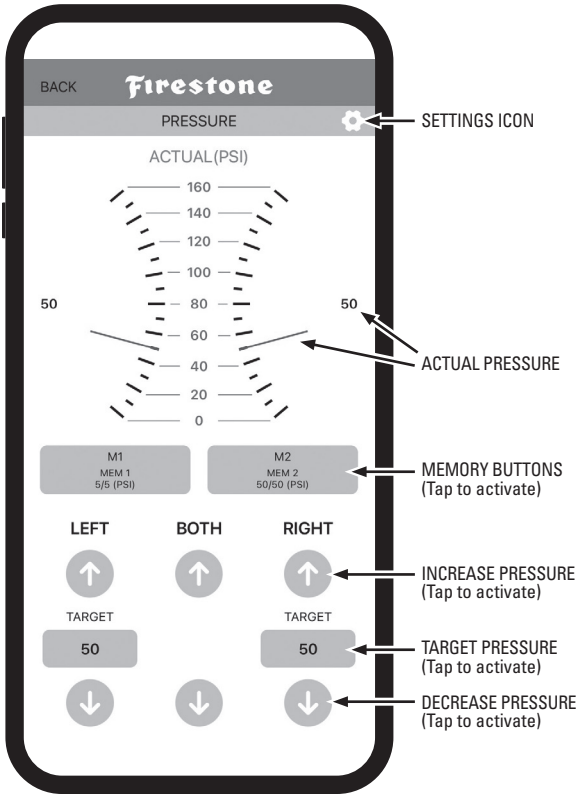

SETTINGS

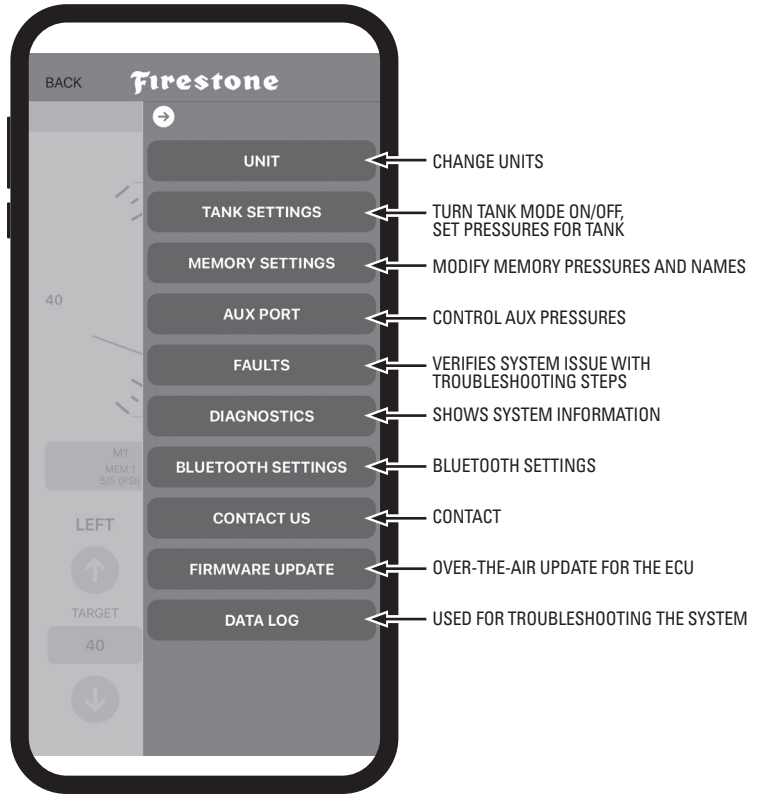

TANK SETTINGS

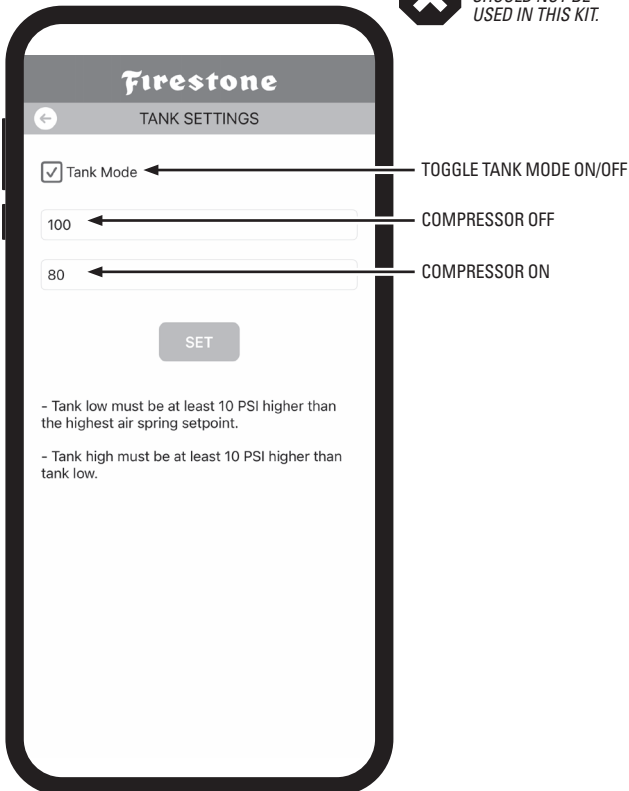

MEMORY SETTINGS

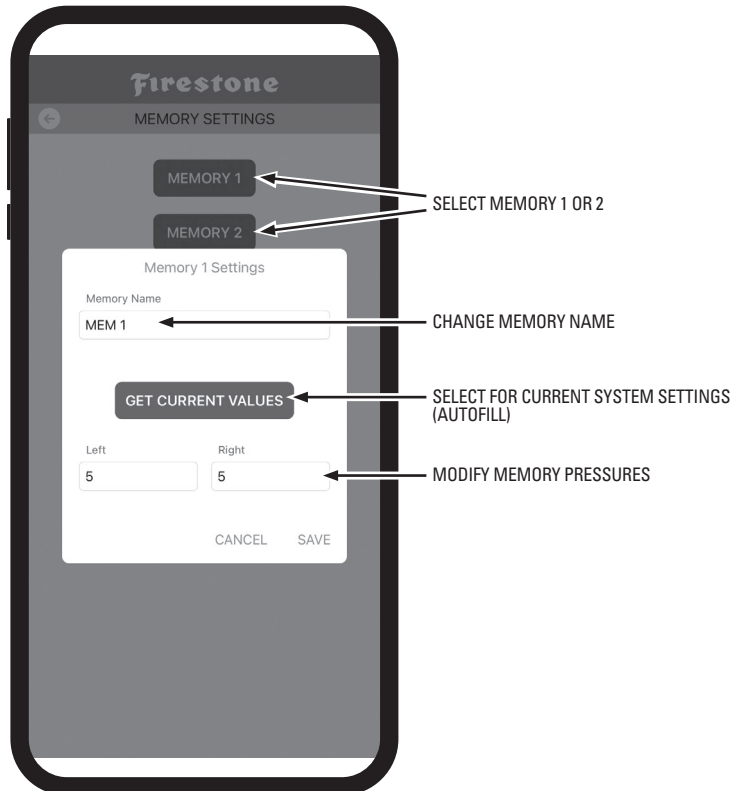

AUXILIARY

X AUXILIARY MODE SHOULD NOT BE USED IN THIS KIT.

SLIDE TO MANUAL AND SYSTEM WILL FILL UNTIL TURNED OFF

SLIDE TO AUTO AND SET PRESSURE

ACTUAL PRESSURE

SYSTEM FAULT

INDICATES SYSTEM FAULT

CLARIFIES INDICATOR CODE

ALLOWS USER TO CLEAR AND ACKNOWLEDGE

DIAGNOSTICS

SHOWS SYSTEM INFORMATION

GREEN INDICATES WHAT PART IS ON

VEHICLE BATTERY VOLTAGE

11

TEST THE SYSTEM

With the Air Command™ Dual App and your Air Springs installed, you are ready to test the system.

- 1 Reattach the negative battery cable.

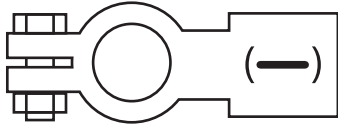

- 2 Turn on your vehicle's ignition.

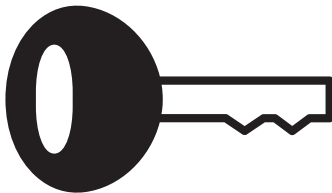

- 3 Use the Air Command™ Dual App or Dual Remote to inflate the Air Springs to 70 PSI. See Step 9 or 10 for details.

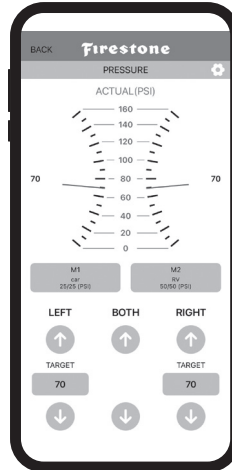

- 4 Spray fittings with soap and water mixture or glass cleaner.



- 5 Observe bubbles.

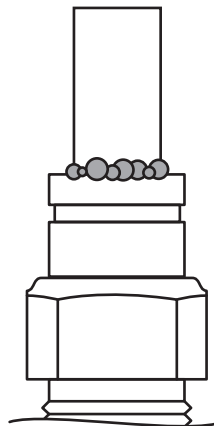

**SMALL SOAP BUBBLES
THAT DO NOT EXPAND**

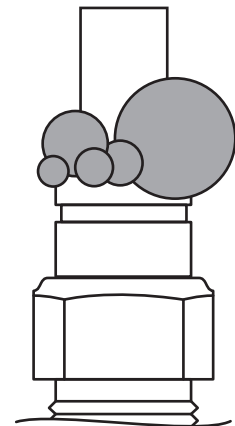

**SOAP BUBBLES
THAT EXPAND**



NO LEAKS?

Congratulations! You're riding right with the push of a button! Remember to review the Operating Instructions.

LEAK?

Bummer. Continue to Step 12 to fix the leak.



EXHAUST ALL AIR FROM THE SYSTEM PRIOR TO RELEASING AIR TUBING FROM AIR FITTINGS.



- 1 Use the Air Command™ Dual App or Dual Remote to deflate the Air Springs to 5 PSI. See Step 9 or 10 for details.

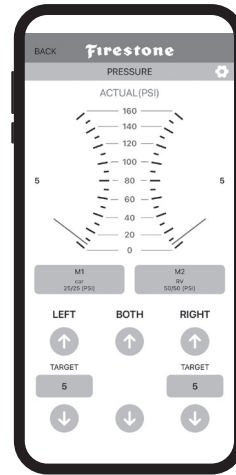

LEAK AT AIR TUBING AND AIR FITTING

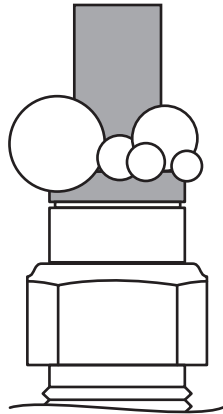

Release AirTubing (see page 4).
Review proper cuts and procedures
in Step 5. Repeat Step 5.

LEAK AT BASE OF AIR FITTING

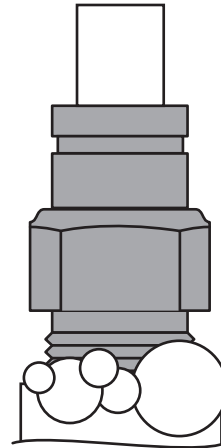

Tighten Air Fitting one turn
or until leak stops.

STILL HAVE A LEAK?

Refer to the Troubleshooting section of the Instruction Manual. If the leak persists, or if there is an issue with a leaking part, email us at rtech@fsip.com. If emailing, please include photos to help us better diagnose and understand any problems you may be experiencing.



AIRIDE

firestoneairide.com

BEFORE YOU DRIVE, CONFIRM THE FOLLOWING:

- Secure all AirTubing and wiring.
- The system passes the leak test and holds air.
- The Air Compressor ground ring terminal is contacting bare metal, and coated with silicone if possible.
- The Wire Harness is grounded to the negative (-) battery terminal. The ECU needs a good, clean, interference-free ground.
- There is a loop in the AirTubing as shown to prevent water or debris from getting into the Air Compressor head and damaging it.

Or, email us at rrtech@fsip.com. If emailing, please include photos to help us better diagnose and understand any problems you may be experiencing.

CONNECT WITH US



@firestoneairide



FirestoneAiride



Firestone Airide



AIRIDE

firestoneairide.com

INSTALLATION INSTRUCTIONS

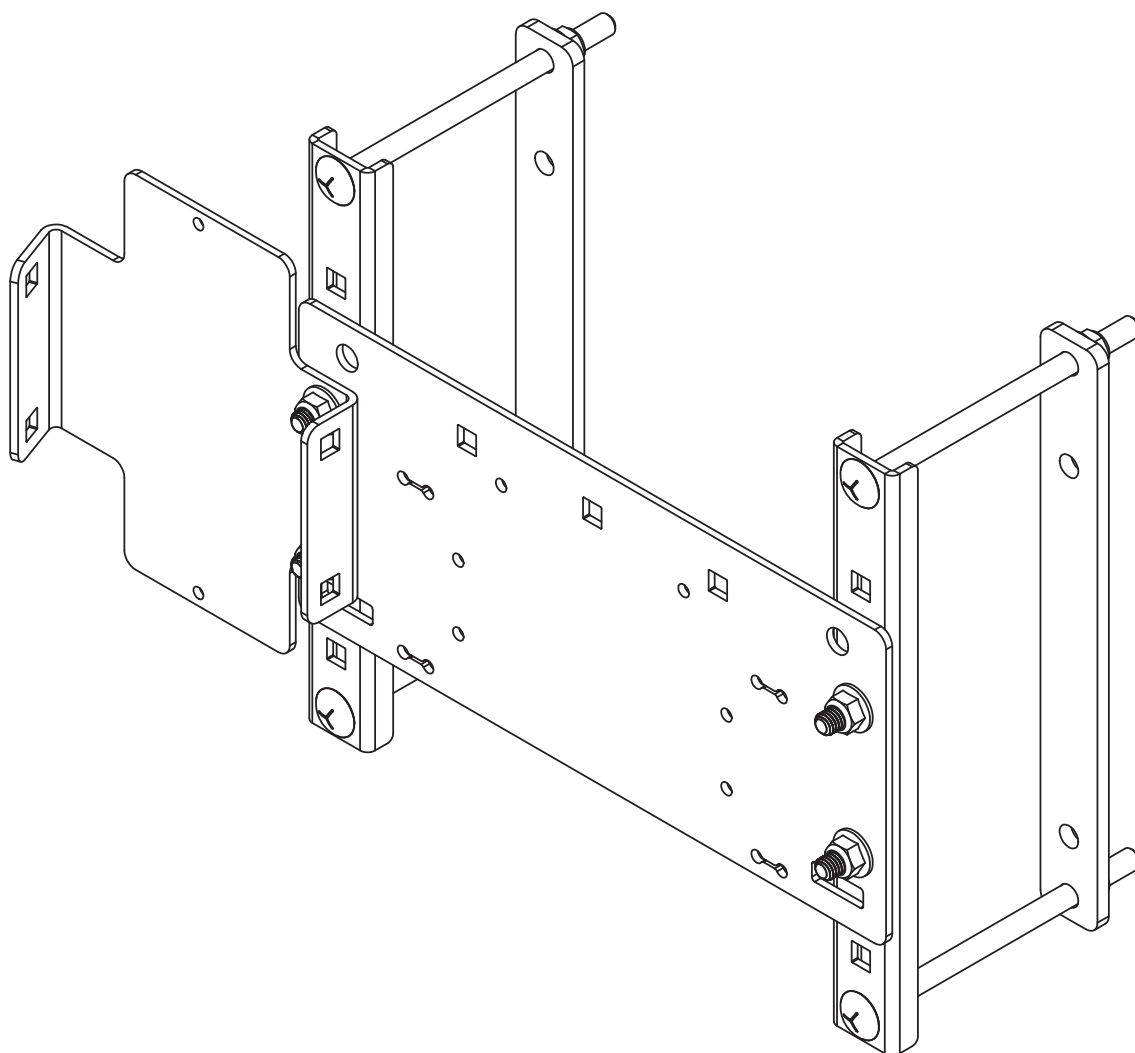

! IMPORTANT

PLEASE DON'T HURT YOURSELF, YOUR KIT OR YOUR VEHICLE. TAKE A MINUTE TO READ THIS IMPORTANT INFORMATION.

DO NOT INSTALL IF THE TRUCK HAS BEEN LIFTED AND THE STOCK JOUNCE BUMPER SPACERS ARE NOT ON THE VEHICLE. *This kit is to be used on a pickup truck only, and DOES NOT INCREASE YOUR VEHICLE'S MAXIMUM LOAD.*

SAFE INSTALLATION

Please take all safety precautions during installation. A hydraulic jack can fail, and if that happens, you can be seriously hurt, or worse, if you are relying on it to hold up the vehicle. If you use a hydraulic jack, secure jack stands in the appropriate locations and chock any tires still touching the ground.

Wear safety glasses or goggles. Your eyes may be lower than some parts and pieces, and you don't want to lose an eye.

Remove the possibility of any electrical issues by disconnecting the negative battery cable.

KIT USES

This kit works with Air Command Kits 2930, 2931, 2933, and 2934. Refer to the following pages for kit-specific layouts to ensure all of the components fit onto the Compressor Mount Plate.

VEHICLE GVWR

NEVER exceed the maximum load recommended by the vehicle manufacturer (GVWR). The GVWR can be found in your vehicle's owner's manual or on the data plate on the driver's side door.

INFLATING THE AIR SPRINGS

When inflating air springs, add air pressure in small quantities, checking air pressure frequently. The air springs have much less air volume than a tire, so they inflate much more quickly.

APPROPRIATE AIR PRESSURE

For best ride, use only enough air pressure in the air springs to level the vehicle when viewed from the side (front to rear). This will vary, depending on the load, location of the load, condition of the existing suspension, and personal preference.



PARTS

Compare the parts below to your kit. Ensure you have all pieces, and organize them for an easier installation.

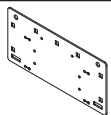
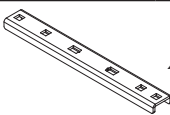
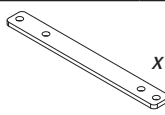
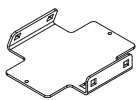
MAIN KIT CONTENTS

PT # 5694	 x1 NO DRILL COMPRESSOR PLATE	PT #5965	 x2 PLATE CHANNEL MOUNT	PT # 5966	 x2 BACKING PLATE
PT # 5698	 x1 ECU MOUNTING BRACKET				

A21-760-2644 HARDWARE PACK

PT # 3067	 x8 3/8"-16 HEX HEAD FLANGE NYLOCK NUT	PT # 3072	 x4 3/8"-16 X 1" CARRIAGE BOLT	PT # 3502	 x8 3/8"-16 X 6" CARRIAGE BOLT
-----------	--	-----------	--	-----------	--

- 1** Mount the No-Drill Compressor Plate to the Plate Channel Mounts shown below.
- 2** Align the Compressor Plate to the bottom of the slots in the Plate Channel Mount.

- 3** Select a suitable location for installation on the vehicle frame rail. Take a tape measure to get a rough height of the frame rail. Use that measurement to determine which holes to use in the mounting plates (distances between holes shown below). It is recommended to mount to the passenger side frame rail as the vehicle's battery is normally located in the engine compartment on the passenger side. Double check before final installation.

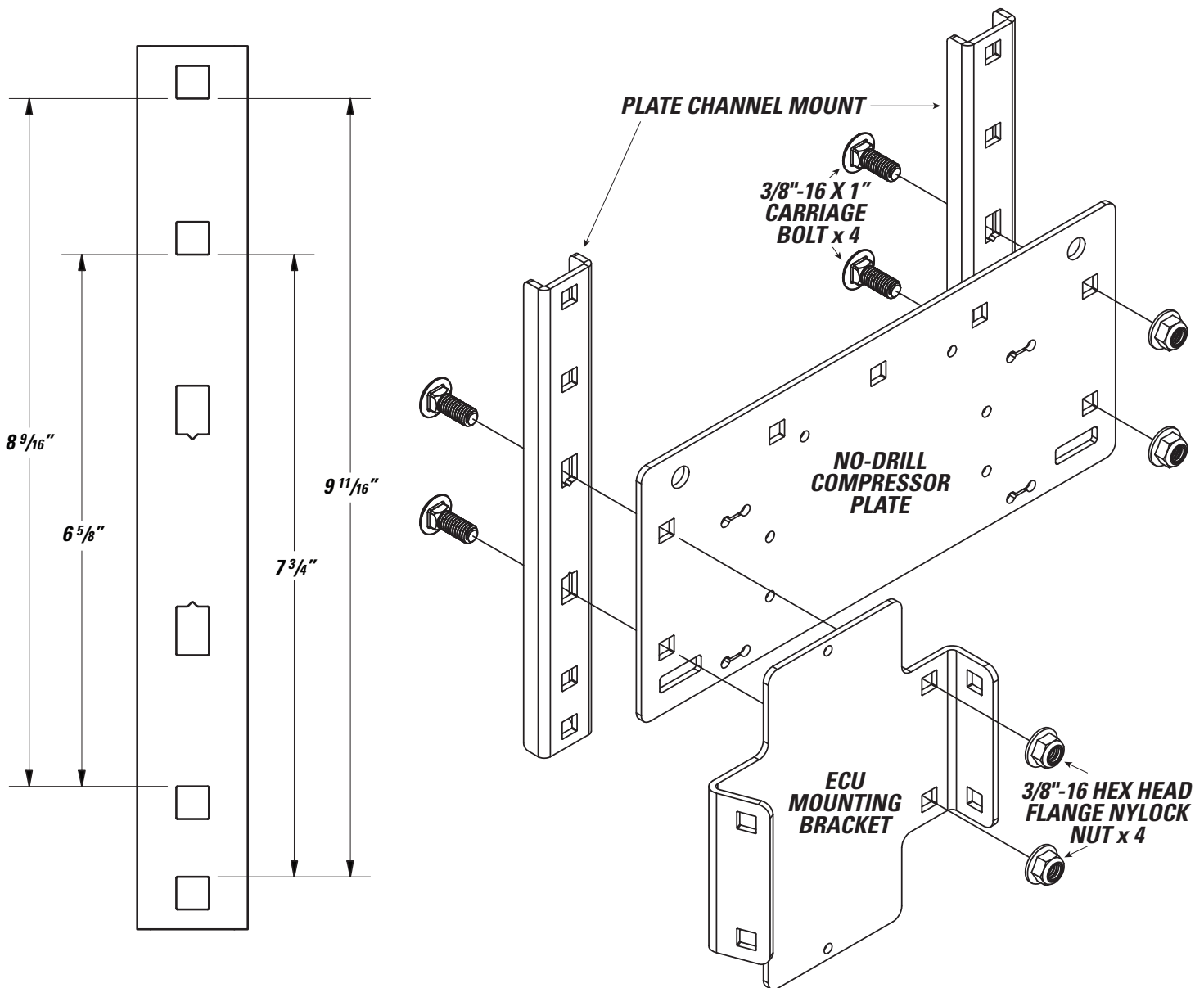
**NOTE:**

The recommended mounting orientation of the ECU Mounting Bracket is shown above. Other orientations are possible if there is not enough space for the width of the assembly. Please see Alternate ECU Mounting Configurations in Section 7 for other potential mounting options. Additional fasteners are included if needed.

2

INSTALL THE ECU

Fasteners included in Air Command Kit



x 2



x 4



x 2



DO NOT OVERTIGHTEN MOUNTING BOLTS AND NUTS ON THE ECU. TOO MUCH TORQUE CAN CRACK THE PLASTIC FEET ON THE ECU.

1 Mount the ECU to the hole locations in the Compressor Plate using the supplied fasteners. DO NOT OVERTIGHTEN.

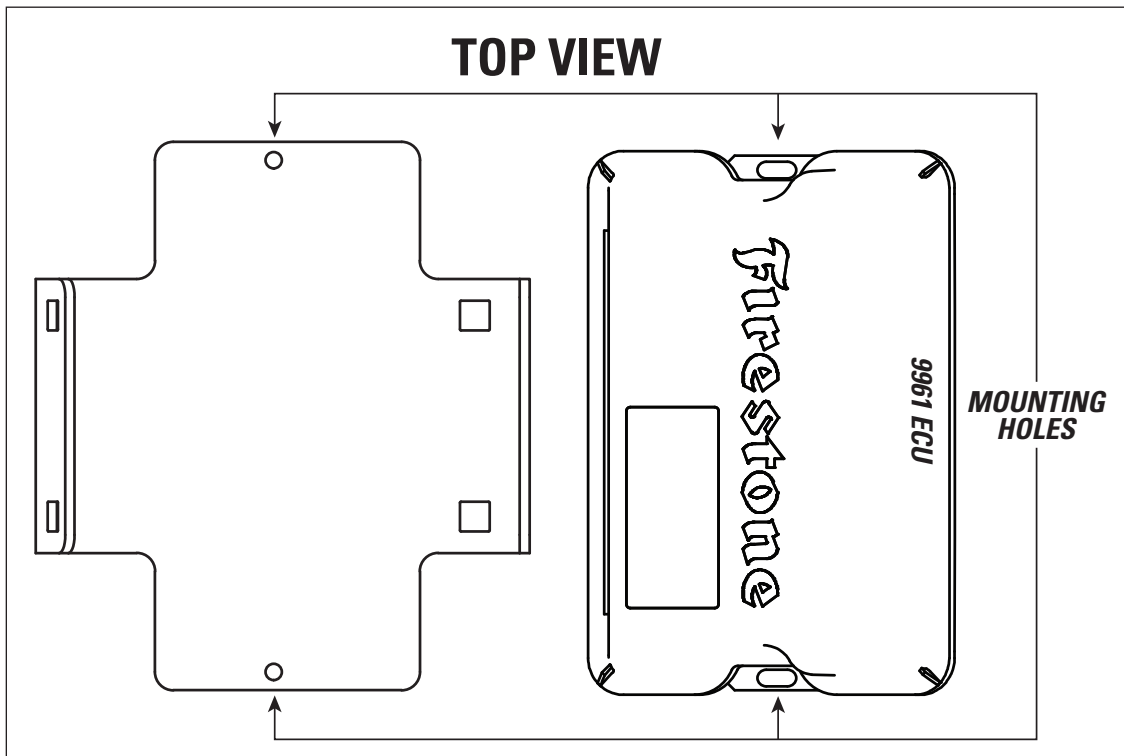
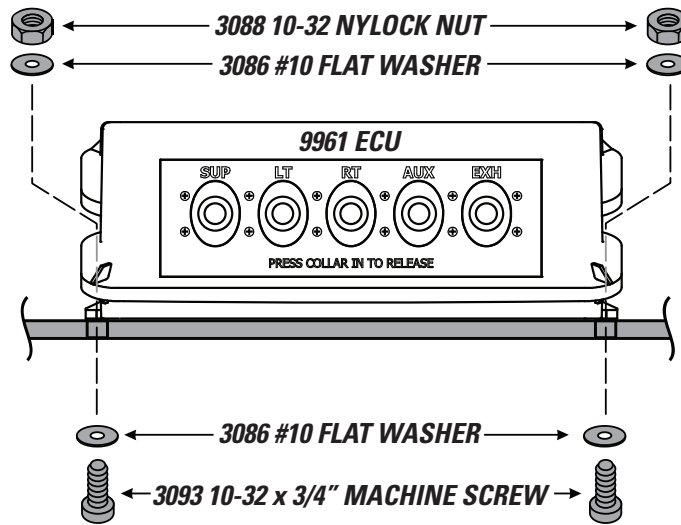

Fasteners included in Air Command Kit



x 4



x 8



x 4

DO NOT OVER TIGHTEN MOUNTING BOLTS AND NUTS ON THE AIR COMPRESSOR. TOO MUCH TORQUE CAN CRUSH THE BRASS INSERTS AND RUBBER ISOLATORS.



1 Mount the Air Compressor to the hole locations in the Compressor Plate using the supplied fasteners. DO NOT OVERTIGHTEN.

2 It is recommended to face the outlet of the compressor towards the air springs on the rear axle of vehicle.

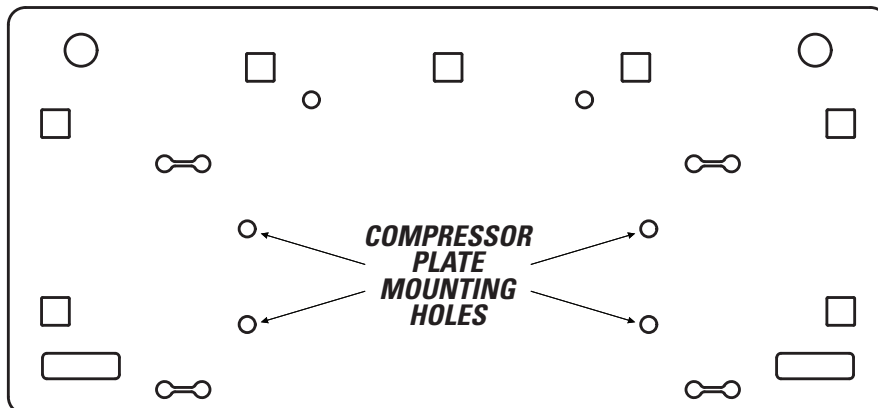
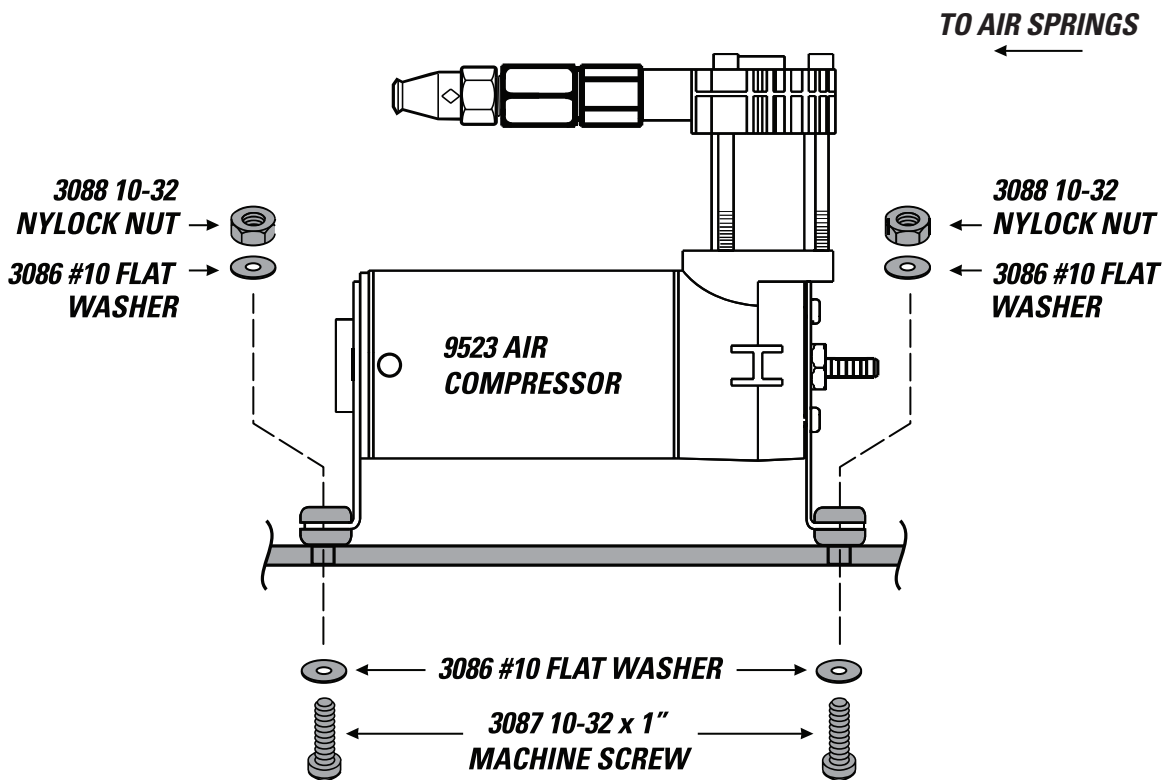

4

MOUNTING TO THE VEHICLE - USE FOR STANDARD DUTY AIR COMMAND KITS 2930 & 2933



AIR ACCESSORY MOUNTING KIT CANNOT BE USED AS A GROUNDING LOCATION FOR THE AIR COMPRESSOR

1 Install the compressor bracket assembly to the vehicles frame rail, using whichever carriage bolt holes are closest to the top and bottom of the vehicle frame as was determined in Step 1.

RECOMMENDED

2 Follow Air Command Kit instructions to run air line from the Air Compressor to the ECU.

3 Continue following the Air Command Kit instructions to connect all air tubing and electrical wiring.

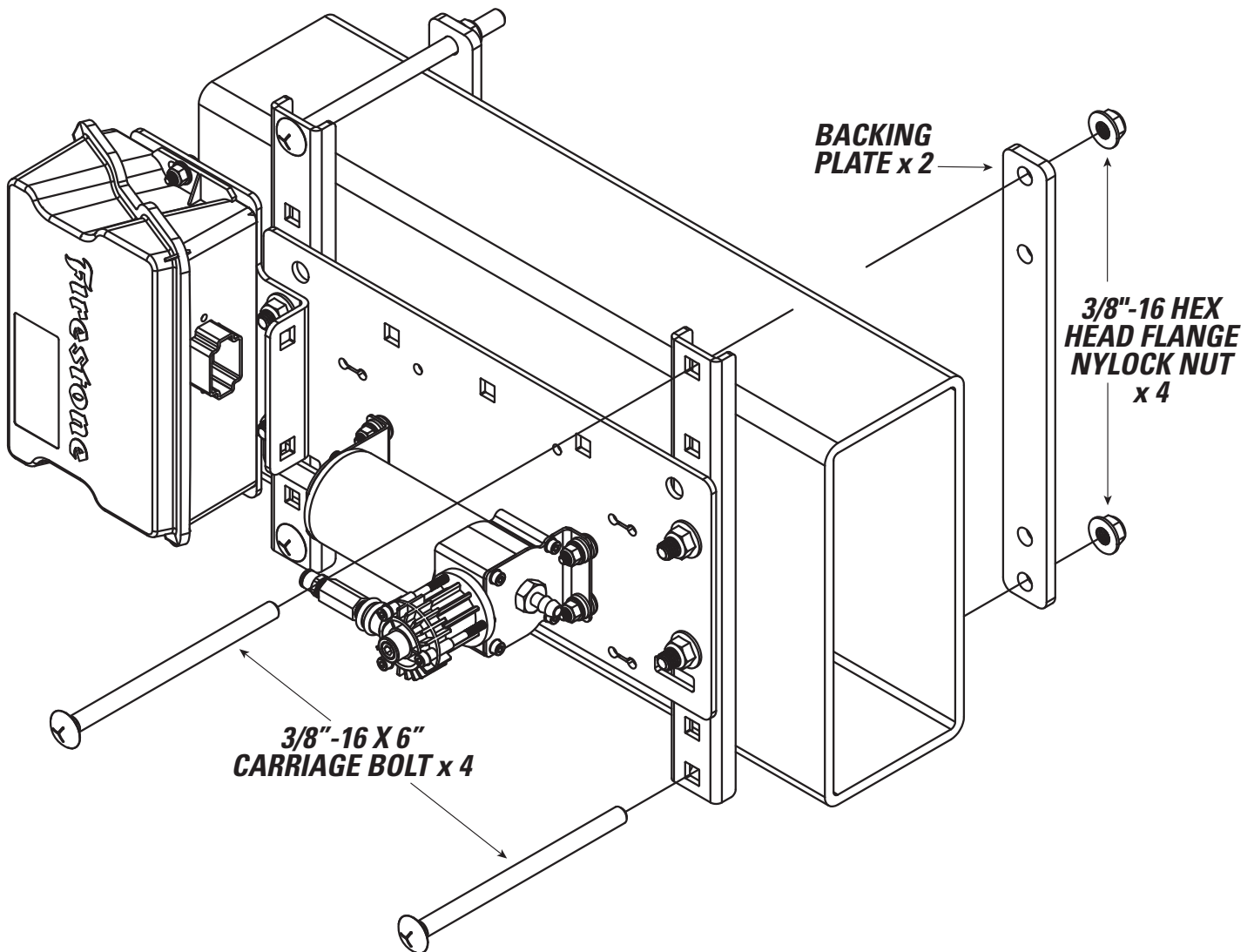

1 In case there is not enough room for the recommended mounting of the ECU Mounting Bracket, additional mounting holes are provided for alternate orientations. Two options are shown below.

2 Use the provided additional 3/8"-16 x 1" Carriage Bolts and 3/8"-16 Hex Head Flange Nylock Nuts to mount the ECU Mounting Bracket.

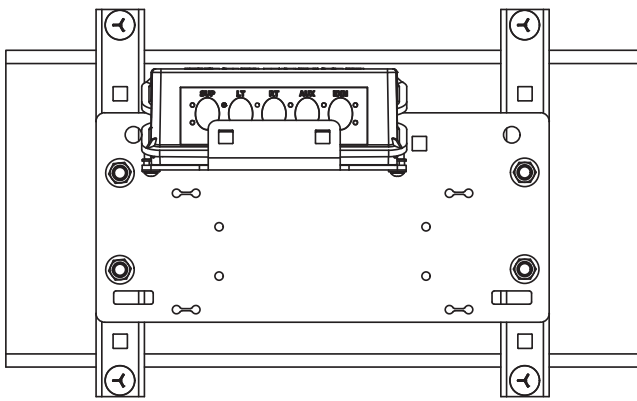

OPTION A

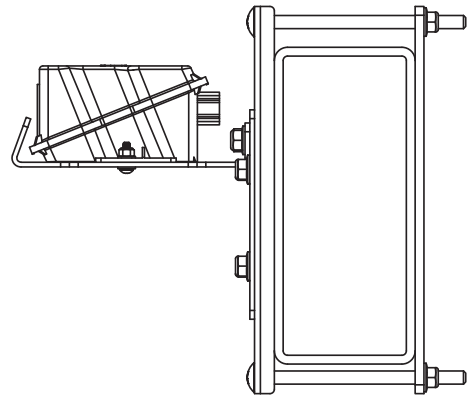
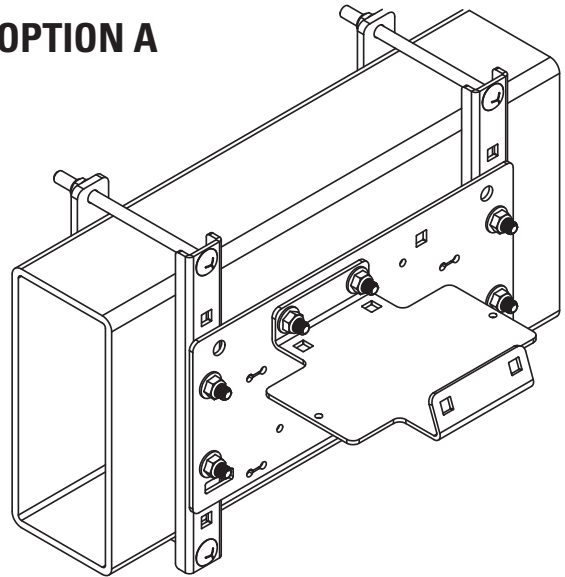

OPTION B

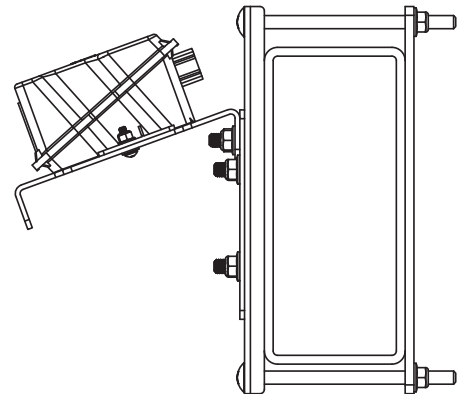
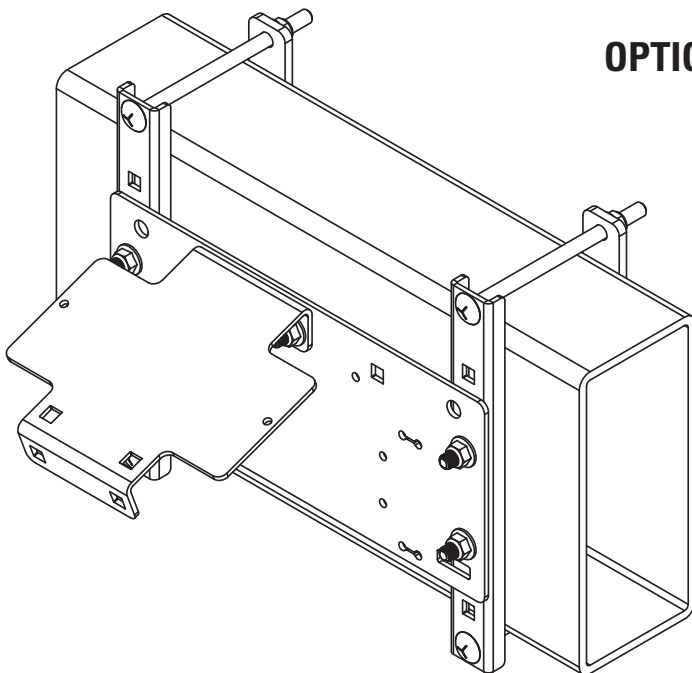



AIRIDE

firestoneairide.com

BEFORE YOU DRIVE, CONFIRM THE FOLLOWING:

- Make sure all fasteners are tight and secure.
- Make sure the installation does not interfere with any other components on the vehicle.
- Reattach negative battery cable.

NEED INSTALLATION HELP?

Email us at rrtech@fsip.com. Please include photos, kit number, and the year, make, and model of the vehicle to help us better diagnose and understand any problems you may be experiencing.

CONNECT WITH US



@firestoneairide



FirestoneAiride



Firestone Airide